

Compendium of Indigenous Wires, Cables and Connectors for Military Aircraft



Compiled by : Anantha Padmanabha SC.E



**CENTRE FOR MILITARY AIRWORTHINESS
AND CERTIFICATION (CEMILAC)
DRDO, MINISTRY OF DEFENSE
MARATHAHALLI COLONY POST
BANGALORE – 560 037**

Compendium of Indigenous Aircraft Wires, Cables & Connectors



CEMILAC
DRDO

Directorate of Aeronautics
Centre for Military Airworthiness & Certification (CEMILAC)
Regional Center for Military Airworthiness (Helicopters)
Ministry of Defence (R & D), Government of India
P.B. No. 1704 Vimanapura Post
Bangalore - 560 017

2015

DOCUMENTATION PAGE

1	Security Classification : Unclassified	2	Distribution: Un Restricted
3	Report status: New	4	Report type: Technical
5	Report No.: DRDO-CEMILAC-TCR-004 -2014	6	Part or volume No
7	Title and subtitle : Compendium of Indigenous Aircraft Wires, Cables & Connectors	8	Contact No : 080-2512 1222
9	No. of pages : -	10	Project no. -
11	Period covered (if progress report) - NA		
12	Personal authors: Anantha Padmanabha, Sc.'E'		
13	Affiliation of authors : Systems Group, CEMILAC, DRDO		
14	Corporate author: CEMILAC, DRDO		
15	Originating unit: Systems Group, CEMILAC, DRDO		
16	Sponsor(s) name : - Nil		
17	Date of submission : April 2015	18	Publication/issue/date: April 2015
19	Publisher/distributor: CEMILAC		
20	Form of distribution	Hard Copy: Yes	Digital: Yes
21	No. of references: Nil		
22	<p>Abstract: Recent advances made in the performance of dielectric materials has led to the development of aircraft cables which differ significantly from those in service in older aircraft types. This compendium is intended to provide comprehensive information on methodology of certification, acceptance of electrical cables and to assist cable manufacturers to adhere to standard practices and users to select the appropriate cables for a particular application. The applicable airworthiness approval will depend on the type of aircraft in which the cable is to be installed. Accordingly cables shall qualify to prevailing governing specifications & standards. Cable manufacturers seeking approval of their products need to comply with the requirements.</p>		
23	Keyword/description: Wires, Cables, Connectors, PTFE, MIL-STD-22759, Airworthiness Certification, GOST standard		
24	Supplementary elements: Nil		

डॉ. के. तमिलमणि
Dr. K. Tamilmani

विशिष्ट वैज्ञानिक
DISTINGUISHED SCIENTIST
महानिदेशक - वैमानिकीय प्रणाली
DIRECTOR GENERAL - AERONAUTICAL SYSTEMS



भारत सरकार - रक्षा मंत्रालय
Government of India - Ministry of Defence
रक्षा अनुसंधान तथा विकास संगठन
Defence Research & Development Organisation
डेयर कैम्पस, पो.बॉ.सं. 9366
DARE Campus, Post Box No. 9366
बैंगलोर / Bangalore - 560 093

No. DG(Aero)/Sectt/DG-DO/2/013

Date: 22 April 2015



MESSAGE

The current generation aircraft has advanced avionics systems with gamut of complex Line Replaceable Units (LRU's) interconnected through electrical wiring system. The performance of the entire aircraft is mainly depends on reliable wiring system. Therefore, selection of aerospace wires & connectors is a critical step to ensure the reliable operation of airborne systems.

Over the years, CEMILAC has certified wide variety of wires, cables & connectors that comply with various Military standards & specifications for aeronautical applications. The experience gained over the decades has been collated & compiled in the form of compendium. The strict adherence to the processes, procedures & testing methodologies highlighted in the compendium will surely enhance the quality of interconnect system which in turn ensure flight safety. The contents can be used as guidelines by designer, manufacturer and users to choose the appropriate wires and connectors for a particular application.

It is a matter of great pleasure that CEMILAC is releasing a compendium on "Indigenous Wires, Cables and Connectors for Indian Military Aircraft" which will serve as a reference handbook for practicing engineers and scientists engaged in the field of aeronautical systems. I congratulate and appreciate the efforts of CEMILAC team and I wish them all the best for their future endeavors.

पी. जयपाल
P. JAYAPAL

मुख्य कार्यपालक (उड़नयोग्यता)
CHIEF EXECUTIVE (AIRWORTHINESS)



D.O. No.
भारत सरकार - रक्षा मंत्रालय
Government of India - Ministry of Defence
रक्षा अनुसंधान तथा विकास संगठन
Defence Research & Development Organisation
सेना उड़नयोग्यता और प्रमाणीकरण केन्द्र (सेमिलाक)
CENTRE FOR MILITARY AIRWORTHINESS
AND CERTIFICATION (CEMILAC)
मारतहल्ली कालोनी (पोस्ट)
Marathahalli Colony (Post)
बेंगलोर / Bangalore - 560 037
भारत / INDIA



Date: 07 Apr 2015

FOREWORD

After many decades of relentless development efforts in pursuit of self reliance in aerospace field, the Indian Industries have now attained significant level of technical perfection in the production of aerospace products. It is heartening to mention that under the stringent guidelines stipulated by CEMILAC, the Indian Industries today are capable of making global standard aerospace wires, cables & connectors. CEMILAC desires that the experience gained during this process of indigenous development of these wires, cables & connectors be compiled and shared with aerospace community. In this regard a compendium has been prepared which broadly covers all the aspects of airworthiness certification requirements, compliance process, testing methodologies, technical parameters, type approval number, manufacturer's details etc.;

I sincerely feel that this document will act as a source of important information on aerospace wires, cables and connectors and I am sure it will be of great value to them who are progressing the ongoing / future development programmes.

The dedicated efforts made by Group Director (Systems) and his team in assimilating the information and compiling the same in an user friendly compendium is very much useful for the ongoing & future developmental programmes and will serve the need of the Aerospace product developers and manufacturers.

(P JAYAPAL)
Chief Executive (Airworthiness)

Date: 07.04.15

एयर मार्शल पी कनकराज अ वि से मे वि से मे
Air Mshl P Kanakaraj AVSM VSM
Tele (Fax) : 0712 - 2512763 (O)



MESSAGE

I am extremely happy to know that CEMILAC, Bangalore is publishing a compendium of CEMILAC certified Aerospace Wires, Cables and Connectors.

Indian Air Force is a capital intensive service wherein weapon systems are bought off the shelf. Due to limited/delayed support from OEM and constant technological changes in outside industries, sustenance of fleets is major cause of concern. Self reliance by way of indigenisation/substitution in the field of aviation is one of the essential key factors to reduce country's dependency on foreign aviation agencies/vendors. Availability of such type of compendium would greatly help design, development and repair agencies during indigenisation/substitution process. The compendium would also serve as a reference guide.

I congratulate all the officers and staff of CEMILAC involved in the project for their concerted efforts to bring out this compendium. Further, I hope CEMILAC comes out with many more such compendium with reference to evolving technologies in indigenous industries. I wish all success in their future endeavor.

Place : Nagpur

Date : 30 Jan 14

(P Kanakaraj)
Air Mshl
AOC-in-C

एस. कार्तिकेयन, वैज्ञानिक 'एफ'
S. KARTHIKEYAN, Scientist 'F'
समूह निदेशक (प्रणाली)
Group Director (Systems)



अ.स.सं/D.O. No.
भारत सरकार - रक्षा मंत्रालय
Government of India - Ministry of Defence
रक्षा अनुसंधान एवं विकास संगठन
Defence Research & Development Organisation
सेना उडनयोग्यता और प्रमाणीकरण केन्द्र (सेमिलाक)
CENTRE FOR MILITARY AIRWORTHINESS
AND CERTIFICATION (CEMILAC)
मारतहल्ली कालोनी पोस्ट आफिस
Marathahalli Colony Post Office
बेंगलूर / BENGALURU - 560 037
भारत / INDIA

दिनांक / Date 07 Apr 2015



PREFACE

A lot of efforts in terms of design, development, airworthiness certification, quality assurance etc; go into realizing an aerospace product. The learning in this process is itself is very satisfying and it is the desire of CEMILAC to record these learning for the future reference / use. In this regard CEMILAC has decided to prepare a compendium on the aerospace wires, cables & connectors which have been type approved and are being produced in the country to share the information with the aerospace community.

Recent advances made in the performance of dielectric materials has led to the development of aircraft cables which differ significantly from those in service in older aircraft types. Consolidating the information on experience gained to date on the operation of existing aircraft cables and the recent developments would be beneficial for the professionals working in the field. This compendium is intended to provide comprehensive information on methodology of certification, acceptance of electrical cables and to assist cable manufacturers to adhere to standard practices and users to select the appropriate cables for a particular application. The applicable airworthiness approval will depend on the type of aircraft in which the cable is to be

3/2

installed. Accordingly cables shall qualify to prevailing governing specifications & standards. Cable manufacturers seeking approval of their products need to comply with the requirements.

I would like to express my sincere thanks to the **beacons** of CEMILAC **Dr. K Tamilmani**, Distinguished Scientist, Director General (Aero) & **Shri. P Jayapal**, Chief Executive (Airworthiness), CEMILAC for their continuous guidance and encouragement to cultivate the culture of maintaining the records of lessons learnt / achievements for sharing with all concerned in the form of compendium, bulletin, data sheet etc;.

I would like to place on record my appreciation to **Shri. A Padmanabha**, Joint Director (Systems) for his relentless efforts in bringing out the Compendium. He has comprehensively compiled all the data like applicable standards, specifications, test methodologies, process verification that are required for indigenous development of cables for use by Indian Military aviation.

I am confident that this document will act as a reference guide and source of information on aerospace wires, cables and connectors and benefit all those who are in the field.

(S Karthikeyan)
Group Director (Systems)



अनंत पद्मनाभा

Anantha Padmanabha

संयुक्त निदेशक (प्रणाली)

Joint Director (Systems)



अ.स.सं / D.O. No.

भारत सरकार / GOVERNMENT OF INDIA
रक्षा मंत्रालय / MINISTRY OF DEFENCE
रक्षा अनुसंधान तथा विकास संगठन
DEFENCE RESEARCH & DEVELOPMENT ORGANISATION
सेना उड़नयोग्यता और प्रमाणीकरण केन्द्र (सेमिलाक)
CENTRE FOR MILITARY AIRWORTHINESS
AND CERTIFICATION (CEMILAC)
मारतहल्ली कालोनी पोस्ट आफिस
MARATHALLI COLONY POST OFFICE
बेंगलूर / BANGALORE- 560 037
भारत / INDIA

दिनांक / DATE: 07 Apr 2015



ACKNOWLEDGEMENT

At the outset I would like to express my sincere thanks to the **Dr. K Tamilmani**, Distinguished Scientist, Director General (Aero) for giving me an opportunity to prepare the compendium. I thank **Shri. P Jayapal**, Chief Executive (Airworthiness), CEMILAC for his continuous support. The compendium would not be possible without the guidance of **Shri. S Karthikeyan**, Group Director (Systems). I express my gratitude for his encouragement during the preparation of the compendium.

I thank M/s Sanghvi Aerospace, Ahmadabad and M/s Amphenol India Pvt Ltd., for providing the necessary material like bulletins, data sheets and standards for compiling this compendium.

I would like to thank all my colleagues of Systems Group, CEMILAC for their reviews and support. I also thank Smt. Suma T H, TO'A' for extending the valuable support in editing the manuscript and compiling & updation of Type Approval record sheets.

Date: 07 Apr 2015

(Anantha Padmanabha)
Joint Director (Systems)

TABLE OF CONTENTS

Part -1: AIRCRAFT WIRES AND CABLES

	Definitions and Abbreviations	3
Chapter-1	1.1 Introduction	16
	1.2 Classification of Wires and Cables	16
	1.3 Classification of Cables	19
	1.4 Cables Specification and Identification	21
	1.5 Construction of Cables	21
	1.6 Cable Performance Parameters	24
	1.7 Aircraft Wiring aging and deterioration	
Chapter-2	Standards and specifications for aircraft wires and cables	
	2.1 Introduction	28
	2.2 British Standard Specifications	28
	2.3 UK Military Specifications	28
	2.4 US Military Specifications	28
	2.5 Manufacturers Specifications	29
	2.6 International Standards	29
	2.7 Russian Specifications and standards	29
	2.8 Specification: TU-16-505.437-73	32
	2.9 Specification: TU-16-505.020-74	34
	2.10 Specification: TU-16-505.911-76	35
	2.11 Specification: TU-16-505.941-76	35
	2.12 Specification: TU-16-505.945-76	36
	2.13 Specification: TU-16-705.014-77	37
	2.14 Specification: TU-16-505.184-78	38
	2.15 Specification: TU-16-505.083-78	39
	2.16 Specification: TU-16-505.554-81	40
	2.17 Specification: TU-16-505.324	41
	2.18 Standard: GOST 24335-80	42
	2.19 Specification: TU-16-505.280-79	42
	2.20 Comparison of MIL-Standard and Russian Specifications	45
	2.21 De-rating criteria for Wires and Cables	50
Chapter -3	Failure analysis and testing requirements for aircraft wires and Cables	
	3.1 Introduction	52
	3.2 Cable Failure analysis	52
	3.3 Arc Tracking	53
	3.4 Abrasion	54
	3.5 Conductor “Knuckling Through”	54
	3.6 Red Plague	54
	3.7 Glycol Fires	54
	3.8 Poor Solderability	54
	3.9 Case Studies of Electrical cable failures	55
	3.10 Qualification Test	56
	3.11 Qualification test details	57

Appendix-A	List of Type Approvals	73
Appendix-B	List of Provisional Clearance	166
Appendix-C	List of Manufacturers	171
Appendix-D	Conversion table for Cables	173

Part -2: CONNECTORS

Chapter -1	1.0 Construction of Connector	184
	1.1 Nomenclature: Cylindrical connectors	184
	1.2 Nomenclature: Cylindrical Connectors and contacts	186
	1.3 Types of Connectors	188
	1.4 MIL-STD-Connectors	207
Chapter-2	2.1 Performance Requirements for connectors	221
	2.2 Marking	224
	2.3 Verification	224
	2.4 Conformance Inspection	224
Appendix-E	List of Type Approvals	228
Appendix- F	List of Connector Manufacturers	239

PART – I

WIRES AND CABLES

DEFINITIONS & ABBREVIATIONS

Abrasion Resistance: Ability of material or cable to resist surface wear.

Alternating Current: The flow of electric charge periodically in reverse direction. Electrical **AC (alternating current)** occurs when charge carriers in a conductor or semiconductor periodically reverse their direction of movement.

Alternating Current Resistance: The resistance offered by any circuit to the flow of alternating current.

American Wire Gauge (AWG): The standard system used for designating wire diameter. Also referred to as the Brown and Sharpe (B&S) wire gauge.

Ampacity: (See current-carrying capacity).

Anneal: To subject (glass or metal) to a process of heating and slow cooling in order to toughen/ strengthen/ harden and reduce brittleness.

Anti-Oxidant: An **antioxidant** is a molecule that inhibits the oxidation of other molecules. Oxidation is a chemical reaction that transfers electrons or hydrogen from a substance to an oxidizing agent.

Armored Cable: A cable provided with a wrapping of metal, usually steel wires, flat tapes, or interlocked tapes, primarily for the purpose of mechanical protection.

ASTM: American Society for Testing and Materials.

AWG: American wire gauge (AWG), also known as the **Brown & Sharpe wire gauge**, is a standardized wire gauge system used since 1857 predominantly in the United States and Canada for the diameters of round, solid, nonferrous, electrically conducting wires. The cross-sectional area of each gauge is an important factor for determining its current carrying capacity.

The gauge can be calculated from the diameter using

$$n = -39 \log_{92} \left(\frac{d_n}{0.005 \text{ inch}} \right) + 36 = -39 \log_{92} \left(\frac{d_n}{0.127 \text{ mm}} \right) + 36 \quad [31]$$

and the cross-section area is

$$A_n = \frac{\pi}{4} d_n^2 = 0.000019635 \text{ inch}^2 \times 92^{\frac{36-n}{19.5}} = 0.012668 \text{ mm}^2 \times 92^{\frac{36-n}{19.5}}$$

Binder: A helically applied tape or thread used for holding assembled cable components in place until additional manufacturing operations are performed.

Boot: A protective covering over any portion of a cable or conductor in addition to its jacket or insulation.

Braid: A fibrous or metallic group of filaments interwoven in cylindrical form to form a covering over one or more wires.

Breakdown (Puncture): A disruptive discharge through insulation due to failure under electrostatic stress.

Breakdown Voltage: The voltage at which the insulation between two conductors, or a conductor and ground will break down.

BS: British Standards

BSI: British Standard Institution

Bunch Stranding: A method of stranding where a single conductor is formed from any number of wires twisted together in the same direction, such that all strands have the same lay length, but no specific geometric arrangement.

Butt Joint: A splice or connection formed by placing the ends of two conductors together and joining them by welding, brazing or soldering.

Butt Wrap: Tape wrapped in an edge-to-edge manner with no over-lapping between adjacent turns.

Cable Core: A cable core is the portion of an insulated cable lying under the protective covering or coverings.

Cable Filler: The material used in multiple conductor cables to occupy the spaces formed by the assembly of components, thus forming a core of the desired shape.

Capacitance: The property of a system of conductors and dielectrics which permits the storage of electricity when potential difference exists between the conductors.

Capacitive Coupling: Electrical interaction between two conductors caused by the capacitance between them.

Charging Current: The current produced when a DC voltage is first applied to conductors of a non terminated cable. It is caused by the capacitive reactance of the cable and decreases exponentially with time.

Chlorinated Polyethylene (CPE): A synthetic rubber jacketing compound.

Circular Mil: A unit of area equals to the area of a circle whose diameter is 1 mil (0.001 inch). Used chiefly in specifying cross-sectional areas of round conductors.

Coating: A material applied to the surface of a conductor to prevent environmental deterioration, facilitate soldering or improve electrical performance.

Cold Joint: A soldered joint made with insufficient heat.

Cold Test: Any test to determine the performance of cables during or after subjection to a specified low temperature for a specified time.

Cold Work: Altering the shape or size of a metal structure by plastic deformation. Processes includes rolling, drawing, pressing, spinning, extruding and heading, it is carried out below the re-crystallization point usually at room temperature. Hardness and tensile strength are increased with the degree of cold work whilst ductility and impact values are lowered. The cold rolling and cold drawing of steel significantly improve surface finish.

Colour Code: A colour system for circuit identification by use of solid colour tracers, surface printing etc.

Compact Stranded Conductor: A concentric stranded conductor where each layer is passed through a closing die to reduce the diameter of the stranded conductor approximately by 10%.

Concentricity: In a wire or cable, the measurement of the location of the center of the conductor with respect to the geometric center of the circular insulation.

Concentric-lay Conductor: Conductor constructed with a central core surrounded by one or more layers of helically laid wires.

Concentric Stranding: (A method of stranding, wherein a single conductor is formed from a central wire surrounded by one or more layers of helically laid wires. Each layer is applied with an opposite direction of lay. The first layer has six wires, and each additional layer has six more wires than does the previous one. Thus the second layer has twelve wires; the third layer has eighteen wires, etc.). These conductors shall be constructed with a central core surrounded by one or more layers of helically laid wires.

Conductivity: A term used in describing the capability of a material to carry an electrical charge. Conductivity is expressed for any standard configuration of a conductor.

Conductor: A wire or combination of wires not insulated from one another, suitable for carrying an electric current.

Conductor Core: The center strand or member about which one or more layers of wires or members are laid helically to form a concentric-lay or rope-lay conductor.

Contra-helical: A term meaning the application of two or more layers of spirally twisted, served, or wrapped materials where each successive layer is wrapped in the opposite direction to the preceding layer.

Core: Any portion of a cable over which some other cable component, such as a shield, jacket, sheath or armor, is applied.

Corona: A luminous discharge due to ionization of the gas surrounding a conductor around which a voltage gradient exists exceeding a certain critical value.

Creep: The dimensional change with time of a material under load. At room temperature, sometimes it is called cold flow.

Creep age: Electrical leakage on a solid dielectric surface.

Crimp Termination: A wire termination that is applied by physical pressure of terminal to wire.

Cross Linking: The establishment of chemical bonds between polymer molecule chains. It may be accomplished by heat, vulcanization, irradiation or the addition of a suitable chemical agent.

Cross Sectional Area of a Conductor: The sum of cross sectional areas of all the individual wires composing the conductor. It is generally expressed in circular mils.

Crush Resistance Test: A test to determine the ability of a cable to resist damage from radial compression, such as might be encountered in service.

Cut-through Resistance: The ability of a given material to withstand penetration by a solid object of specified dimensions and weight, which is permitted to free fall onto this material from a specified height.

De-rating Factor: A factor used to reduce a current carrying capacity of a wire when used in other environments from that for which the value was established.

Dielectric Breakdown: The voltage at which a dielectric material is punctured; which is divisible by thickness to give dielectric strength.

Dielectric Constant: That property of an insulating material which is the ratio of the parallel capacitance of a given configuration of electrodes with the material as the dielectric, to the capacitance of the same electrode configuration with a vacuum as the dielectric.

Dielectric Strength: The voltage which an insulating material can withstand before breakdown occurs, usually expressed as a voltage gradient (such as volts per mil).

Dielectric Tests: Tests which consist of the application of a voltage higher than the rated voltage for a specified time for the purpose of determining the adequacy against breakdown of insulating materials and spacing under normal conditions.

Direction of Lay: The lateral direction, designated as left-hand or right-hand, in which the wires of a member or units of a conductor run over the top of the member or conductor as they recede from an observer looking along the axis of the member or conductor.

Eccentricity: A measure of the lack of coincidence of longitudinal axes of a circular cross-sectional wire and its surrounding circular cross-sectional insulation. It is expressed as the percentage ratio of the distance between wires and insulation centers to the difference between wire and insulation radii.

Elastic Deformation: A change in a substance, whereby it reverts to its original dimensions on release of an applied stress.

Elongation: The fractional increase in length of a material stressed in tension.

Embossing: A means of marker identification by means of thermal indentation leaving raised lettering on the sheath material of cable.

Extrusion: The process of continuously forcing either a plastic or elastomer and a conductor or core through a die, thereby applying an insulation or jacket to the conductor or core.

Fault Current: The maximum electrical current that will flow in a short-circuited system prior to the actuation of any current-limiting device. It is far in excess of normal current flow and is limited only by a system's generating capacity and a cable's impedance.

Fibrous Filler: A material used to fill interstices in cables made from fibers, such as jute, polypropylene, cotton, glass etc.

Filler: Any material used in multi-conductor cables to occupy interstices between insulated conductors or form a core into a desired shape (usually circular).

Film: Thin sheet of plastic having nominal thickness usually not greater than 0.010 inch.

Flame Resistance: The ability of a burning material to extinguish its own flame, once its flame-initiating heat source is removed.

Flame Retardance: Ability of a material to prevent the spread of combustion by a low rate of travel so the flame will not be conveyed.

Flexing Test: Any test to determine the ability of a cable to withstand repeated bending and twisting.

Flex Life: The number of bends or twists, of specified type, that a cable will withstand before failure.

Ground: A conducting connection, intentional or accidental, between an electric circuit or equipment and the earth or some conducting body serving in place of the earth.

Ground Potential: Zero potential with respect to the ground or earth.

Grounded Neutral: A circuit operates with grounded neutral when the neutral is metallically connected to ground and there is a provision for immediate removal of a faulted element.

Grounding Conductor: A conductor used to connect equipment or the grounded circuit of a wiring system to a grounding electrode or electrodes; usually coloured green.

Hard-drawn Wire: As applied to aluminum and copper, wire that has been cold drawn to final size so as to approach the maximum strength obtainable.

Heat Endurance: The time of heat aging that a material can withstand before failing a specific physical or electrical test.

Heat Resistance: Ability of a substance to maintain physical and chemical identity and electrical integrity under specified temperature conditions.

Heat Shock: A test to determine stability of a material by sudden exposure to a high temperature for a short period of time.

High Voltage Time Test: It is an accelerated life test on a cable sample in which voltage is the factor increased.

Hygroscopic: Attracting or absorbing moisture from the ambient atmosphere.

ICEA: Insulated Cable Engineers Association. An Association of Engineers of most cable manufacturers.

Irradiation: The exposure of a material to high energy emissions.

Jacket: A material covering over wire insulation or an assembly of components, usually an extruded plastic or elastomer.

JAR: Joint Airworthiness Requirements

Jumper: A short length of conductor used to make a connection between terminals, around a break in a circuit, or around an instrument.

Lap Splice: A permanent joint formed in a short overlapping region of two parallel conductors or tapes. Also called parallel splice.

Lay: The distance along a cable occupied by one complete helix of a strand or conductor.

Marker Tape: A narrow strip of fabric, paper or plastic lay longitudinally within a cable; it bears printed information such as the specification to which the cable was made and the name of the cable's manufacturer.

Marker Threads: Coloured strings laid parallel and adjacent to the strands of an insulated conductor to reveal information such as the conductor's manufacturer, the specification to which it was made, or its thermal capability.

Mil: Unit of measure equal to 1/1000 of an inch.

Moisture Absorption: The amount of water that an insulation or jacket, which is initially dry, will absorb under specified conditions. It is expressed as the percentage ratio of the absorbed water's weight to the weight of the jacket or insulation alone.

NEMA Standards: Property values adopted as standard by the National Electrical Manufacturers Association.

Nominal: Name or identifying value of a measurable property by which a conductor or component or property of a conductor is identified, and to which tolerances are applied.

NTSB: National Transportation Safety Board.

Oxygen Bomb Test: A test to determine the ability of conductors and insulations to withstand physical and electrical change when immersed in pure oxygen gas of specified temperature and pressure for a specified time.

Plating: Any thin metallic coating applied over a metallic substratum.

Polychloroprene: Chemical name for neoprene. A rubber-like compound used for jacketing where wire and cable will be subject to rough usage, moisture, oil, greases, solvents and chemicals.

Polyester: A resin generally used as a thin film in tape form.

Polyethylene: A thermoplastic material composed of polymers of ethylene.

Polypropylene: A thermoplastic polymer of propylene.

Polyvinyl Chloride (PVC): A thermoplastic material composed of polymers of vinyl chloride, which may be rigid or elastomeric, depending on specific formulation.

Potting: Applying a hydrostatic seal and mechanical reinforcement by means of a thermosetting liquid, this cures either at room temperature or at a slightly elevated temperature.

PTFE: Poly Tetra Fluro Ethylene commonly known as **Teflon®**.

Quad: A structural unit employed in cables, consisting of four separately insulated conductors twisted together.

Resistance: Property of a conductor that opposed the current flow produced by a given potential difference. Ohm (Ω) is the practical unit of resistance.

Rupture: In the breaking strength or tensile strength tests, the point at which a material physically comes apart as opposed to yield strength, elongation, etc.

Secondary Insulation: Any extremely high resistance material which is placed over primary insulation to protect it from abrasion.

Serve: Any helical wrapping applied over a wire or cable core. It may consist of wires, fibers, yarns or tapes.

Served Wire Shield: A barrier to the passage of interference formed by a helical wrapping of wires over a cable core. It is also called spiral shield.

Sheath: The material usually an extruded plastic or elastomer, applied outermost to a wire or cable. Very often referred as a jacket.

Shield: Any barrier to the passage of interference - causing electrostatic or electromagnetic fields, formed by a conductive layer surrounding a cable core. It is usually fabricated from a metallic braid, foil or wire serving.

Shield Coverage: The amount of cable core surface area which is covered by a shield. It is expressed as a percentage of the cable core's total surface area. It is also called braid coverage when applied to a braided shield.

Shielding: The practice of confining the electrical field around a conductor to the primary insulation of the cable by putting a conducting layer over and/or under the insulation.

(External shielding is a conducting layer on the outside of the insulation. Strand or internal shielding is a conducting layer over the conductor itself).

Skeleton Braid: A braid of widely separated wires or fibers, used to reinforce a jacket, bind a cable core, or prevent the passage of electrostatic or electromagnetic fields.

Soft Wire: Wire that has been drawn or rolled to final size and then heated to remove the effects of cold working.

Spark Test: A test designed to locate pin-holes in an insulated wire by application of an electrical potential across the material for a very short period of time while the wire is drawn through an electrode field.

Specific Inductance/Capacitance: That property of a dielectric material which determines how much electrostatic energy can be stored per unit volume when unit voltage is applied.

Specific Resistance: The resistance of a unit conductor having a length of one foot and across-sectional area of one circular mil.

Spiral Wrap: A term given to describe the helical wrap of a tape or thread over a core.

Splice: A joint used for connecting two lengths of conductor or cable with good mechanical strength as well as good conductivity.

Stranded Conductor: A conductor composed of a group of wires, usually twisted, or of any combination of such groups of wires.

Strand Lay: The distance of advance of one strand of a spirally stranded conductor, in one turn, measured axially.

Stress Cone: A conical section built up of insulating tapes or a pennant to relieve the stress at the terminal end of the cable

Tank Test: A voltage dielectric test where the specimen to be tested is submerged into a liquid (usually water) and a voltage potential applied between the conductor and the liquid as ground.

Tape Wrap: A term denoting a spirally or longitudinally applied tape material wrapped around the wire, insulated or un-insulated, used as an insulation or mechanical barrier.

Tear Strength: The force required to initiate or continue a rip in a jacket or other insulation under specified conditions.

Temperature Rating: The maximum temperature at which a given insulation or jacket may be safely maintained during continuous use, without incurring any thermally-induced deterioration.

Tensile Strength: The longitudinal stress required to break a specimen of prescribed dimension divided by the original cross-sectional area at the point of rupture.

Termination: The load connected to the output end of a transmission line. The provisions for ending a transmission line and connecting to a bus bar or other terminating device.

Thermal Conductivity: Ability of material to conduct heat.

Thermal Endurance: The time in hours at a selected temperature for an insulating material to deteriorate to some predetermined level of electrical, mechanical, or chemical performance under prescribed conditions of test.

Thermal Expansion (Coefficient of): The fractional change in length (sometimes volume) of a material for a unit change in temperature.

Thermal Rating: The maximum and/or minimum temperature at which a material will perform its function without undue degradation.

Tinned Wire: Copper wire that has been coated during manufacture with a layer of tin or solder to prevent corrosion or facilitate soldering.

Triad: Any grouping of three conductors or three assemblages of conductors, generally twisted together and found within a cable.

Triplex: Three single conductors twisted together, usually three single conductor cables twisted without over-all covering.

Ultra Violet Degradation: The degradation caused by long time exposure of a material to sunlight or other ultraviolet rays containing radiation.

Voltage Drop: The voltage developed between the terminals of a circuit component by the flow of current through the resistance or impedance of that part.

Voltage Rating: The maximum voltage at which a given cable or insulated conductor may be safely maintained during continuous use in a normal manner. It is also called working voltage.

Water Absorption: The ratio of the weight of water absorbed by a given material under specified conditions, to the weight of that material when dry. It is generally expressed as a percentage.

Wicking: The longitudinal flow of a liquid in a wire or cable construction due to capillary action.

Wire Gauge: Any of several standard systems for designating wire sizes. As an example, see American Wire Gauge.

Work Hardening: The increased stiffness and brittleness accompanying plastic deformation of metal.

Yield Strength: The lowest stress at which a material undergoes plastic deformation. Below this stress, the material is elastic; above it, viscous.

CHAPTER I

AIRCRAFT WIRES AND CABLES

1.1 Introduction

Modern commercial and military aircraft wiring not only distributes electrical power but provides control and information links between multiple systems and sub-systems. The components that make-up the wiring system include power and control conductors, signal and instrumentation conductors, fiber optic cables, connectors, circuit breakers, relays, power distribution and control panels. Failure of any of these components can disable an aircraft or compromise an aircrew's ability to control the aircraft. It is for these reasons aircraft wiring is to be considered as a critical and vital component on aircraft.

Historically, aircraft wiring was treated as a "fit and forget" commodity rather than as an indispensable system. While there is a tendency to ignore wire systems, there is a need to manage wire systems so that they continue to function safely. It is for these reasons the aviation industry and government have developed regulations, codes, standards and operational practices that focus on maintaining the integrity of the aircraft wiring system for aircraft safety.

1.2 Classification of Wires & Cables

Unfortunately, there is little International Standardization of terminology is available on aircraft wires and cables. It should be noted that the term 'wire' is used in the USA whereas most other countries talk of 'cable'.

Wire is a single conductor and cable is a group of two or more insulated conductors. If there is no insulation on the two conductors then it would not be a cable, it would still be a single conductor which would classify as a wire.

There are two types of wire. These are solid wire and stranded wire. Both types have different uses depending on the level of resistance and flexibility required. Solid wire is a single solid conductor that may be bare or insulated. This type of wire offers considerably a lower resistance. Solid conductors are the key to better performance at higher frequencies.

Stranded wire is made up of several strands of bare conductor to form a single conductor when all strands are put together. This type of wire has more flexibility and a longer flex life before becoming unusable.

There are five basic cable types as follows:

Twisted pair cable

- (a) Multi-conductor cable
- (b) Coaxial cable
- (c) Fiber optics cable
- (d) Shielded cables

(a) **Twisted pair cable:** It consists of pair of conductors that are twisted together.

This cable is specifically intended for signal carrying. This type of cable was invented in the 1880's for the specific intent of wiring up early telephone systems. Twisting the pair of conductors gives the cable some immunity to interference. It is considered as balanced line configurations if two conductors are kept very close together, normally by twisting them. Conductors must be the same length, size, and have a constant distance between them.

(b) **Multi-conductor cable:** It is the cable that is made up of many insulated conductors. This type of cable is common in control applications but is almost never used in signal applications.

(c) **Coaxial cable:** Coaxial cable does not have the immunity to interference that twisted pair cable does, but the performance may be more stable with coaxial cable than with twisted pair cable because of the fact that various parts of the cable are “knitted” together.

(d) **Fiber optics cable:** This cable is divided into three types viz. Plastic Fiber, Multi Mode Fiber, and Single Mode Fiber. Plastic fiber is used in high end audio signals. Multi mode fiber is made of glass with different diameters, and is used in the data world. Single mode fiber is considered the king, or the best, because the fiber is too small to see without a microscope. This fiber gives the best performance but is very difficult to connectorise because of fiber size and hardness.

- (e) **Shielded cables:** Unshielded cable may be used where there is no crosstalk or noise present. This configuration can also be used if noise is not important or will not substantially affect the signal. Shields are added to cables to prevent noise interference and radiation. There are five configurations of shields involved in cable. These are Braid Shields, Serve/Spiral shields, French Braid Shields, Foil Shields, and Combination Shields.
- i. **Braid Shields** are manufactured by spinning conductors or groups of wires around a center core. The braiding process is very labor intensive, which makes it the most expensive step of the cable making process. The braiding can be single or double braid, with double braiding being more effective. Since there are always holes where the wires cross, braiding is never 100% effective. The higher the frequency the less effective a Braid Shield is.
 - ii. **Serve/Spiral Shields** are manufactured to be extremely flexible. Serve Shield effectiveness is compromised by the fact that every time the Serve Shield is flexed it opens up. A Spiral Shield has an effect on the inductance of the shield and so these shield configurations are normally used for audio not for video.
 - iii. **French Braid Shields** are a combination of a Serve Shield and a Braid Shield. This shield consists of two Serve Shields braided along a single axis. This shield gives excellent flexibility and RF performance. The French Braid Shield takes the same effort and material as a Braid Shield so the manufacturing process costs roughly the same for both.
 - iv. **Foil Shields** are the cheapest and easiest shield to apply. They consist of two different layers. One layer is metal and the other layer is a polyester substrate. This shield can be applied just as quick as the cable can be run. These shields show performance for low-frequency to be poor but performance for high-frequency to be excellent. Since Foil Shields are made with foil that has no holes, they can be 100% effective.

- v. **Combination Shields** are shields that use a combination of braiding and foil. Sometimes there are multiple layers of each. Combination Shields are the most expensive of all shields. These shields give the best broadband coverage because the foil works for high frequencies and the braiding works for low frequencies.

1.3 Classifications of Cables

1.3.1 Airframe Cables

Cables designated as 'Airframe' are intended to be sufficiently robust to satisfy the requirements of 'Open' airframe wiring and the general wiring of Power plants. However, in recent years there has been a strong trend towards very thin insulation which is harder and stiffer than insulation such as PVC. Such 'stiff' cables are perfectly satisfactory if the installation is designed to accept them but they may very well be quite unsuitable for an older airframe design requiring, say, flexing over hinges. It follows that even if all the major declared characteristics such as overall diameter and temperature rating are acceptable, the apparently equivalent cables may still not be interchangeable.

There are two basic methods of applying cable insulation, namely wrapping and extruding. These methods in themselves can produce different 'handling' Characteristics and in paragraphs 5 and 6 of this Leaflet, this and other factors defining cable performance are reviewed. In the USA, the term 'Medium Weight-Interconnect' may be used for Airframe Cables.

1.3.2 Interconnect Cables

'Interconnect' is a term adopted by the BSI to designate cables which may be used in protected areas of wiring such as the interconnection of equipment within racks. Such cable would normally be installed within an assembly which would then be positioned into an aircraft. It would not, therefore, be subject to 'pulling through' and other such stressful exercises. Interconnect cables employ thinner insulation than airframe types, which saves weight and space and increases flexibility, the latter being most important where looms (bundles) are required to turn through small radii into electrical connectors. However, all the constraints given in paragraph 3.1 for airframe cable also apply here. The term 'Hook-up' is

commonly used in the USA to designate cables of this general type, and the designation 'Light Weight-Interconnect' may also be applied.

1.3.3 Equipment Wire

This wire is intended to be used within equipment and, therefore, is very flexible and suitable for soldering. It is not designed for use as interconnect wiring but design organizations do, on occasions, select a particular type for use in protected areas of an airframe. There is a considerable range of such cables which vary in basic construction and performance and they should always be very closely defined. In general, the types in aircraft use are produced by CAA approved organizations who provide 'CAA Release' to British Standard G210 or an equivalent specification. The term 'Module Wire' is sometimes used for this class of cable in the USA.

1.3.4 Fire Resistant Cables

This type of cable is required to retain a defined level of electrical insulation in the presence of fire for five minutes, as defined in BCAR Section D1-2 paragraph 1.17,2 and JAR 1. 'Fire Resistance' should not be confused with 'high temperature' and fire resistant types should only be employed where this property is required because other characteristics, such as fluid resistance, will usually be poorer than could be expected from a non fire resistant high temperature cable.

1.3.5 Fire proof Cables

These cables are required to operate for fifteen minutes in a designated fire as defined in BCAR D6 paragraph 6.5.1 and JAR 1 and are for use in designated fire zones. BCAR D6-13 paragraph 6.6.2 and JAR 25.1359 define a fire zone. As for Fire Resistant types, they should only be used where necessary.

1.3.6 Multi core Screened and Jacketed Cables

Airframe and interconnect cables may be supplied in a multi core form of generally up to four cores, the cores being twisted together. The multi core may be jacketed (sometimes known as a sheath) or it may be screened and jacketed. The screening is usually a braid which gives 85% surface coverage, but screening to a higher standard may

be used, and on replacement of such cables, the standard must not be degraded. The cores are coloured for identification as defined in BS G230.

1.3.7 Data Bus cable

Data Bus cables are designed to specific requirements which will not, as a general principle, allow for replacement by any other type other than that specified by the Design Authority for the installation. (This requirement will also apply to the terminations of such cable).

1.4 Cable specifications and identification

Because of the large number of specifications exist for aircraft cables, it is impractical to list all those in this compendium. Significant differences can occur between cables complying with the same basic requirements. It is also difficult to offer guidance on interchangeability between products. The details of cable specification and standards are covered in chapter '2' of this compendium.

1.5 Construction of cables

1.5.1 Conductors

For equipment interconnection and airframe cables, the conductors are normally of the stranded type and are usually made from plated copper. However, size 24 and smaller sizes of conductor will be of copper alloy having a higher tensile strength. Fire resistant cables may also be of copper alloy or copper conductors throughout all applicable sizes. The total conductor consists of plated strands which are circular in section and which are laid up into one of a number of stranded forms. Aluminium conductors are also available for cables of size 8 and larger but such cables have not been without problems. Any modification which involves conversion from copper to aluminium should be classed as 'major' and thoroughly investigated, especially in regard to termination techniques. Obviously, 'aluminium cables' will need to be significantly larger in cross section than copper for a given electrical load because of the higher electrical resistance of aluminum.

1.5.2 Conductor Plating

Plating is employed on copper, copper alloy and aluminium conductors to improve resistance to corrosion and to assist termination techniques. Very often it is the plating which will determine the temperature rating of a given cable. Tin plated copper maximum continuous temperature is 135°C. Silver plated copper maximum continuous temperature is 200°C. Nickel plated copper maximum continuous temperature is 260°C. Nickel Clad plated copper maximum continuous temperature is 260°C. Nickel clad copper is used instead of nickel plate on fire resistant cables to provide a thicker nickel element.

The temperature figures quoted above may have to be varied downwards because of limitations imposed by the cable insulation. Higher figures, notably 150°C for tin plating, are sometimes quoted but performance at such temperatures, especially in regard to stable crimp resistance and solderability is the subject of debate. It should be noted that the plating used on crimped terminal ends must be compatible with the conductor plating of the cable.

1.5.3 Dielectric Materials and Cable Types

It is not practicable to review in this compendium the performance of all of the many types of cable designs available except in general terms. Extensive studies have been made in an attempt to determine an optimum cable type. It may be noted that there is not an overall best cable and that all the materials studied have advantages and disadvantages. This is little help to a user who is seeking to resolve the conflicting guidance and advice offered by organizations which have a keen commercial interest in the decisions of an intending purchaser.

Insulation material is applied to conductors by one of two basic methods called extrusion and wrapping. In general terms, extrudable materials are 'heat meltable' and are not employed for higher temperature applications. It follows that towards the upper limit of their operating temperature, their mechanical strength when measured by abrasion or cut through, can be significantly less than that measured at room temperature. Airframe categories of cable usually have a double extrusion which is not always of the same material. A double extrusion is also claimed to impart 'crack stopping' qualities. Radiation cross linking of processed material is employed on high performance cables and this

eliminates melting, increases strength and allows for thinner wall thickness. Cables employing such design perform well on wet arc tracking.

The most commonly used wrapped insulation material is Kapton¹, which is the registered trade name to an aromatic polyimide produced by Dupont. Many cable manufacturers world-wide use Kapton, either singly or in combination with other materials to give a hybrid construction. Single or double tapes are spirally wound over the conductor to a defined overlap to give the required tape thicknesses at any one point. Kapton is naturally copper coloured and it is usual to apply a top coat to provide a coloured surface which will accept print and also give added protection to the cable. Use of cables complying to MIL-W-81381/11 have been discontinued in some environments. This would not reflect the general rejection of cables containing Kapton. Most designs provide good overall performance including excellent mechanical strength especially the hybrid types.

The process of wrapping insulation provides good control of insulation wall thickness and there are now cable types which employ only 4 layers of 'Kapton', giving a total wall thickness of approximately 0.006 inches. These are employed throughout the airframe of some recently certified aircraft. The CAA has not granted an Accessory Approval as 'Airframe' types to such cables, these having been accepted on a 'Component' basis. However, all PVC cables are now classed as 'Obsolescent - unsuitable for new designs'.

1.5.4 Wire Insulation

Wire insulation should be selected based on flame resistance, smoke emission requirements and the environmental characteristics of the wire routing areas. Insulating materials should be selected for the best combination of the following characteristics:

- a) Abrasion resistance
- b) Corrosion resistance
- c) Dielectric strength
- d) Flame resistance
- e) Mechanical strength
- f) Resistance to fluids
- g) Smoke emission
- h) Arc resistance
- i) Heat distortion temperature

The four most common types of insulating materials used in aircraft today are shown in Table below

Table 1
Comparative Properties of Wire Insulation Systems

Polymer	Mil Specs	Desirable Properties	Limitations
PTFE (Teflon)	22759/12	260°C thermal rating, low smoke/non-flame, high flexibility	Cut-through resistance, “creep” at temperature
ETFE (Tefzel)	22759/16	Chemical resistance, abrasion resistance, ease of use	High temperature, cut-through, thermal rating (150°C)
Aromatic Polyamide (Kapton)	81381	Abrasion/cut-through, low smoke/non-flame, weight/space	Arc-track resistance flexibility
Composite (TKT)	22759/80-92	High temperature rating (260°C), cut-through resistance, arc-track resistance	<i>Outer layer scuffing</i>

When choosing wire insulation it is imperative to not only to seek the best balance of electrical, mechanical, chemical, and thermal properties but also inherent flame and/or smoke resistance.

1.6 Cable Performance parameters

The definition of cable performance has increased in complexity and precision with the reduction of insulation thickness and weight. Some of the cables now used for airframe wiring have no more than 0.006" of insulation thickness and thus there is little margin for error in manufacture or in an aircraft installation. The operating temperature dictates to a large extent the materials and constructions used, but installation requirements need to be satisfied by defining properties such as resistance to insulation 'cut-through' and abrasion. It follows that cables need to be selected with care and the factors detailed below should be considered in relation to any intended use.

Wiring integrity and safety issues have surfaced as a major aviation crisis associated with the loss of Swissair flight 111 in 1998 and TWA flight 800 in 1996. Aircraft wiring is the vital electrical and optical network that transmits the data, signals and power to and from systems. Wiring problems cause loss of signals, system shutdowns, smoke, fires, and explosions. In addition, wiring problems costs a lot in troubleshooting and maintenance. Ensuring flight safety entails more immediate detection of electrical malfunctions and better fire suppression methods. However, avoiding flight tragedies involves improving wire inspection techniques. Therefore aircraft wiring is required to be visually inspected. But a large portion of electrical wiring on aircraft is not readily visible because it is bundled with dozens of other wires or blocked from view by other structures or components. In general performances of cables are governed by the following parameters.

1.6.1 Temperature

The temperature rating of a cable must be defined to permit comparison with the worst case requirements of the application. It follows that the location of a cable, relative to hot air ducts and local hot spots such as power transformers and some filament lighting must be known. Cables have a specified maximum continuous operating temperature, and for many types, this may be achieved by any combination of ambient temperature plus temperature rise due to I^2R losses. However, it should be noted that in general, it is undesirable to contribute more than a 40°C rise by electrical heating as the operating temperature and cable life are directly related. The temperature rating of an airframe cable is determined by its construction and will be classified at one of the following temperatures: 105°C (obsolescent cable types), 135°C, 150°C, 210°C and 260°C. Clearly this temperature rating has to be known when evaluating any design application.

1.6.2 Cable Size

Cable is usually identified by a size number which approximates to the A.W.G. (American Wire Gauge) size of the conductor. However, some cables employ a number which refers to the square millimeters of a conductor cross section, which is a system used extensively in Russian GOST specification. The size of cable is the primary determinate of the electrical protection level set by the circuit breaker or fuses and should never be reduced below the level established by proper co-ordination data. Manufacturers usually publish rating data for single cables in free air and for bundles of three cables in free air. By study of the short term and continuous ratings for a given cable type and size, the correct

protection can be determined. Current rating data usually relates to a temperature rise of 40°C above ambient as stated above and due allowance must be made for such electrical heating. Manufacturers' data will normally include conductor resistance in ohms per Kilometer at 20°C and a temperature correction may be necessary if accurate voltage drop calculations are necessary. It should be noted that cable 'size' relates only to the conductor and thus the overall diameter and surface finish for a given size may vary significantly between cable types.

1.6.3 Voltage Rating

All cables have a rated voltage. Particular reference should be made to the specified voltage of any cable where higher than normal potentials may be used, in places such as discharge lamp circuits and windscreen heating circuits.

1.6.4 Flammability and Toxicity

All cables are required to have a defined level of resistance to burning when exposed to standard flame tests. In addition to the requirements for flammability, there exist general requirements relating to the hazards of smoke and toxicity. In recent years, greater emphasis has been placed upon these characteristics.

1.6.5 Wet Arc Tracking

A requirement has now been formulated to assess the 'resistance to failure' of cables when subjected to a combination of insulation damage and fluid contamination. The propensity of some insulating materials to 'track' has long been studied in high voltage systems but it has now been found necessary following a lot of failures noticed in the recent past. Tracking can also occur under dry conditions and this failure mode reinforces the need for good cable installation and good maintenance practices.

1.6.6 Mechanical Properties

The assessment of cable insulations includes the ability to withstand the pressure of a sharp edge and for the ability to withstand scraping with a defined blade. It is these tests which figure significantly in assessing airframe cable and which are the controlled methods of replacing assessment by scraping with the thumb nail. As noted earlier, differing designs

result in marked changes in handling properties especially with regard to stiffness and springiness. Installation of looms of thin wall hard dielectric cable has to have regard to the reluctance of such looms to be 'set' in position, especially if the supporting structure is flimsy. It must not be assumed that this apparent strength is translated into the ability to withstand physical abuse.

1.6.7 Fluid Contamination

Cables are required to display a defined level of resistance to the effects of commonly used aircraft fluids but this is not to say that cables can withstand continuous contamination, which should be avoided. It follows that where a new cable type is introduced, the compatibility with such compounds should be checked. Equally, the use of a new fluid on an aircraft, e.g. new types of hydraulic fluid, should be considered in relation to the ability of cables to withstand contamination.

Aircraft Wiring Ageing and Deterioration

All aircraft electrical wiring systems are liable to ageing during their normal service life. Ageing results in the progressive deterioration of physical properties and performance of wiring systems with the passage of time. Wiring is susceptible to more rapid deterioration with age in areas of high contamination, vibration, temperature variation, and corrosion and where it is attached to movable or removable parts. The aging process can be significantly accelerated by frequent handling or maintenance actions on or near the wiring systems. As aircraft continue to fly for long periods of time, the occurrence of wire degradation gets higher consequently, increasing the number of wire failures. **FAR 25** states: "that insulation material can't be used that is hazardous, unreliable, or contributes smoke/fire."

CHAPTER II

STANDARDS AND SPECIFICATIONS FOR AIRCRAFT WIRES & CABLES

2.1 Introduction

A very large number of specifications exist for aircraft wires and cables. Thus it is impractical to list all those in this compendium. Significant differences can occur between cables complying with the same basic requirements. It is also difficult to offer guidance on interchangeability between products. The following information has been compiled to assist in the recognition of the specifications and wire/cable selection.

The following different specifications & standards are available for development of aircraft wires and cable for both civilian & military aircraft applications.

2.2 British Standards Specifications (BSS)

The majority of cables used on British built aircraft now in service have been produced to 'G' specifications e.g. BS G221 for Minyvin. Aircraft cable specifications are issued in the Aerospace G Series of British Standards and are referenced in the BSI Year Book. Newer Standards are based upon general requirements given in BS G230. A series of 'Detailed Standards' numbered sequentially from G232 has been published and these define cable design requirements and physical characteristics. The CAA grants Accessory Approval to cables which comply with these standards but an additional Manufacturers Detailed Specification which defines the precise construction will also be required by the CAA.

2.3 UK Military Specifications

Military aircraft produced by a European consortium will have their own cable specifications and a typical example is the **Panavia** project which has produced PAN specifications. These military specifications are for referential purposes and CAA does not validate such specifications.

2.4 US Military Specifications

The designation of US Military Specifications for cable is usually MIL-W-XXXX. Each MIL Specification has a number of 'slash sheets' and the requirements of such individual

sheets can encompass a large range of cables. It is absolutely essential to know the full designation of any MIL Specification cable and to replace with equivalent cables.

2.5 Manufacturers Specifications

Aircraft manufacturers may publish specifications and some of the most frequently seen are Boeing - BMS, Douglas - BXS, Airbus Industries - AR or ASNE,, BAC (Concorde) – BAS. These cables are approved in relation to the aircraft on which they are installed by the manufacturer, i.e. a cable which is approved for use by one manufacturer may not necessarily be acceptable to another.

2.6 International Standards ((including European standard)

The official body for the standardization of aircraft equipment, including cable, is the ISO (International Organization for standardization). The BSI contributes to the work of the ISO but a few ISO cable standards are employed by industry. Within Europe, the SBAC works in association with other manufacturers in the organization known as AECMA (Association Europeenne Des Constructeurs De Materiel Aerospatiale). AECMA seeks to promote their own standards and they publish European 'Normes' as EN specifications. These have not yet been widely adopted, but preliminary specifications published are known as prEN Standards. ISO and EN Standards may be recognised for installation purposes except that it is not usually within the boundaries of the CAA to grant product approval against a specification not controlled by BSI.

2.7 Russian specifications & standards

2.7.1 GOST certification (Gosstandard)

GOST is the valid quality certification system in Russian Federation. It is called GOST-R Certification. GOST is very important for Russian companies and exporters in Russia and carries the same meaning of ISO 9000 series certificates for the western companies. GOST is the approved quality indicator for Russia.

GOST Certification is not only engaged with the quality management of any company, but also focused on the products of it. To obtain this certificate the tests of samples are necessary. These tests are carried out at accredited laboratories by

GOSSTANDARD. (Russian Governmental Standards Organization). Based on the results of these tests the certificates are given to the prospective company.

For obtaining these certificates, the production system analysis and the products of related company shall be checked and investigated for the conformity of Russian norms by the authorized auditors. Product will be tested according to Russian Federation standards of quality. The Certificate Organs are under strict control of GOSSTANDARD. These Organs are situated mainly in Moscow. Each Organ has its own area. The Certification Organs are entitled to issue certificates only for the products belonging to their accredited area. GOST certification is based on analysis of production similar to the ISO 9000 Certification.

2.7.2 Russian Specification

Materials, used for manufacturing of wires cables should correspond to the following: -

Table 2

Tinned copper wire	- TU 16-505.850-75
Tin-and-lead solder	- GOST 21930-76
	- GOST 21931-76
lavsan silk cloth	- OST 6-06-03-75
Triacetate silk cloth	- TU 6-06-483-75
Polyethylene terephthalate film	- GOST 24234-80
Polyvinyl chloride (PVC) plastic	
Grade I40-14 or I40-13A for	
Insulation & for casing	- GOST 5960-72
Copper wire	- GOST 2112-79
Ultrathene grades 11306-075,	- TU 16-05-1636-78
Dust milled quartz	- GOST 9077-82
Colophony cable	- TU 81-05-25-77
Colophony pine	- GOST 19113-73
Low-molecular polyethylene	
(for compound)	- TU 6-05-1837-77
High pressure polyethylene	
Grade 107-61 k (for insulation)	- GOST 16336-77
Painted polyvinyl chloride plastic	
Concentrated paint	- TU 6-01-747-77

2.7.3 Decoding of Part Number of Russian wires & Cables

Each Alphanumeric symbol of part number has a specific meaning. The details are as follows.

- (a) B: External
- (b) P: Wire
- (c) V: Vinyl chloride Insulation
- (d) L: Varnished
- (e) E: Shielded
- (f) D: Two layer insulation
- (g) 0: Irradiated/sheathed
- (h) U: Strengthened Core
- (G) M: Interior/Small size
- (k) S: Glass
- (l) A: Asbestos
- (m) T: Heat Resistant
- (n) F: Fluoroplastic Insulation
- (O) I: Wear resistant
- (P) Z: Protection of shield surface
- (q) N: Heat resistant/Nickel plated
- (r) R: Rubber insulation
- (s) G: Flexible
- (t) Sh: Silk braiding

Aircraft wires & cables that are manufactured complying to various Technical Specifications are listed below for reference. Characteristics, Applications & different cable variants are also indicated wherever information is available.

2.8 Specification: TU 16-505.437-73

Applications: These cables have two layers of impregnate natural silk. These are used in internal control circuits.

2.8.1 MLTP

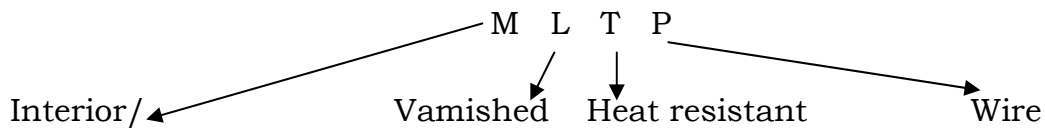

MLTP : Temperature resistant wire with insulation made of polyethylene and lavsan with copper core.

Variants

MLTPG: Same as MLTP , with flexible core.

MLTPE: Same as MLTP, with shielding.

2.8.2 BPVL

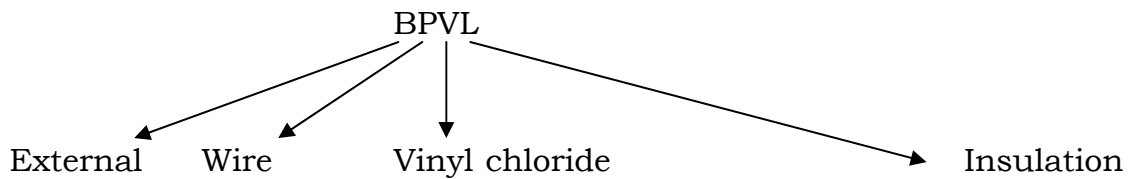

BPVL-Wire with tinned copper core having PVC insulation in braiding made from cotton yarn varnished and shielded for airborne mains.

Variants

BPVLE- same as BPVL, with shielding.

BPVLM- Wire with tinned copper core having PVC insulation, in combined braiding made from glass and caperone threads varnished, small sized.

BPVLM E- same as BPVLM, with shielding.

Characteristics

Classification	: External Non-Heat Resistant
Voltage Rating	: 500 Volts
Temperature Range	:-60 to +700 C
Operating Frequency	: Up to 2000 Hz
Conductor	: Copper Tinned
Insulation	: Vinyl chloride

2.9 Specification: TU 16-505.020- 74

Applications: This cable is meant for fixed installation and used for aircraft wiring in the fuselage. These cables are resistant to wear and tear and heat. They are durable to oil and fuel.

2.9.1 BIF

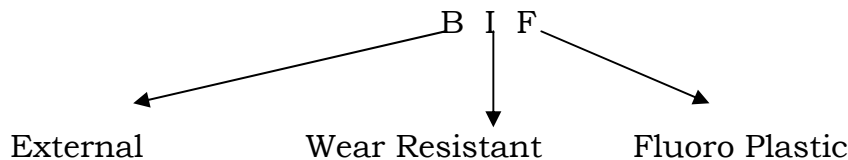

BIF: These wires are used in Airborne systems and not effected by Oil AMG-IO mark-8, Gasoline B-70 paraffin T-1,T-2 and fluid 7-505-3.These wires evolve toxic gases when heated up over + 200°C.

Variants:

- BIFE** : Same as EIF, but shielding.
- BIFEZ** : Same as BIFE, but protected.
- BIF-N** : Strand made of Nickel-plated wire.
- BIFE-N** : Same as BIF-N, but shielded.
- BIFEZ-N** : Same as BIFE-N, but protected.

Characteristics

Classification	: External Heat Resistant
----------------	---------------------------

Voltage Rating : 250 Volts
 Temperature Range :-60 to 200° C
 Operating Frequency : 2000 Hz
 Conductor : Copper Silver Nickel Plated
 Insulation : Polyamide Fluoroplastic

2.10 Specification TU 16-505.911-76

Applications. Different grades of these wires are used in different Aircraft systems such as internal lighting, fuel and power systems. BPVLM cables are combustible but durable to oil petrol mixture.

2.10.1 BPGRL

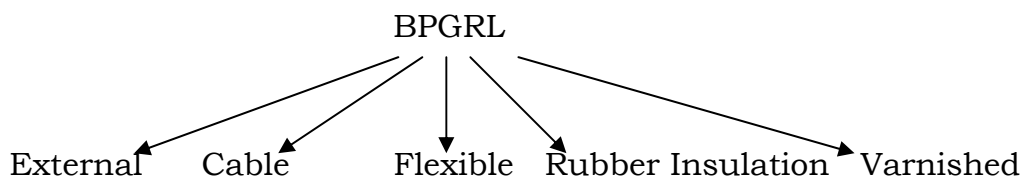

BPGRL - Flexible, with insulation of silicon rubber with lavson coating and lacquered. These strands of it's core are made of annealed silver-plated copper.

Variants : Nil
 Classification : External Heat Resistant
 Voltage Rating : 250 Volts
 Temperature Range : -60 to 1250 C
 Operating Frequency : 1000 Hz
 Conductor : Copper Silver-plated
 Insulation : Rubber

2.11 Specification: TU 16-505.941-76

Applications: These wires find their applications in power, Starting and Propeller feathering circuits. The screened versions of these wires are used in Radio, Fuel and Air Conditioning systems of aircraft.

2.11.1 MGS HV

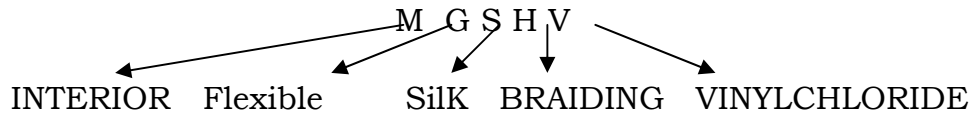

MGS HV: Current carrying core is made of tin plated copper having film or fibrous polychlorovinyl insulation.

Variants

- MGS HV : Same as MGS HV, with shielding.
- MGS HV EV : Same as MGS HV, with polychlorovinyl insulation.
- MS HV : Same as MGS HV

Note: Cables are manufactured in green, red, pink, blue, sky blue, black, purple, yellow, orange, brown, white and natural colors.

Characteristics

- Classification : Internal Non Heat Resistant Flexible
- Voltage Rating : 250 Volts
- Temperature Range : -50 to +70°C
- Operational Frequency : 5000 Hz
- Conductor : Tinned Copper
- Insulation : Polychlorovinyl, Electrical Insulation Fibers

2.12 Specification: TU 16-505.945-76

Applications: These wires are used for aircraft harness, and are heat and wear resistant.

2.12.1 BFS.

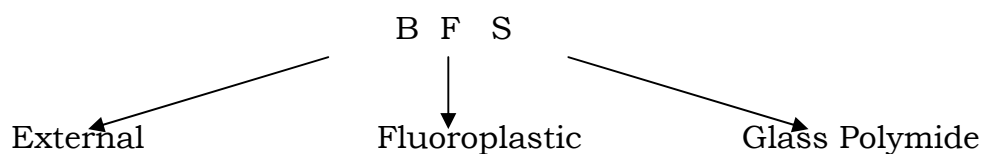

BFS: Core is made of strands of nickel plated wire with glass polyamide fluoro plastic insulators.

Variants:

BFSE: Same as BFS~with shielding.

BFSEZ: Same as BFSE, with a sheath over the shield.

Characteristics

Classification : External Heat Resistant
Voltage Rating : 250 Volts
Temperature Range :-60 to +250° C
Operating Frequency : 2000 Hz
Conductor : Copper Nickel Plated
Insulation : Glass Polyamide Fluoroplastic

2.13 Specification TU16-705.014-77

Applications: These cables are heat resistant and do not spread combustion. They are used in aircraft harness.

2.13.1 MS

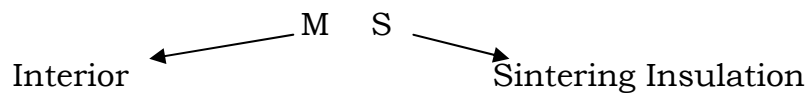

MS: Core is made of strands of copper silver plated wires and insulation material is caking film, can be used upto 100V.

Variants

MSE -16-13 : Same as MS-16-13 With Shielding.

MSEO-16-13 : Same as MSE-16-13, with another additional sheath.

MS-26-13 : Same as MS-16-13, 250 V.

MSE-26-13 : Same as MS-16-13, with shielding.

- MSEO-26-13 : Same as MSE-26-13 with another additional sheath.
- MS-36-13 : Same as MS-16-13 but for voltages up to 500 V.
- MSE-36-13 : Same as MS-36-13, but with shielding.
- MSEO-36-13 : Same as MSE-36-13 but with another additional shield.

Depending on the number of strands required the cable can be designated as follows:

- MS-16-13 1 x 0.5 has one strand of 0.5 mm cross section
- MS-16-13 2 x 0.5 has two strands of 0.5 mm cross section.

Characteristics

- Classification : Internal Heat Resistant Wire
- Voltage Rating : MSI.Series 100 Volts
: MS2. Series 250 Volts
: MS3.Series 500 Volts
- Temperature Range :-60 to +200° C
- Operating Frequency : 10000 Hz
- Conductor : Copper Silver-Plated
- Insulation : Caking Fluoroplastic Film

2.14 Specification TU 16- 505.184-78

Applications: These wires are flexible with Rubber Insulation and used in controls and landing gear systems where the moving parts are subjected to bending.

2.14.1 BIN

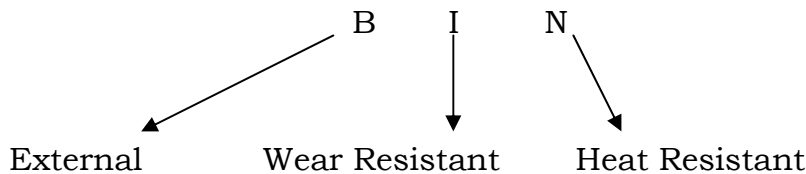

BIN: Silver coated copper wire core with glass fluoroplastic insulation.

Variants:

- BINE : Same as BIN, with shielding.
- BINEZ : Same as BI1E, with protected cover.
- BIN-N : Nickel coated copper wire core with glass fluoroplastic insulation.

BIN-N-E : Same as BH'IJ"-N, with shielding.
 BIN-N-E-3 : Same as BIN-N-E, with protective cover.

Characteristics:

Classification : External Heat Resistant
 Voltage rating : 250 Volts
 Temperature Range :-60 to +250° C
 Operational Frequency : 2000 Hz
 Conductor : BIN Copper Silver Plated /BIN-N Copper Nickel plated
 Insulation : Glass Fluoro Plastic

2.15 Specification TU16-505.083-78

Applications: These wires do not spread combustion. They are durable to the effect of oil, grease and petrol. These are used in aircraft starting system, fuel system and aircraft missile launchers.

2.15.1 BPDO.

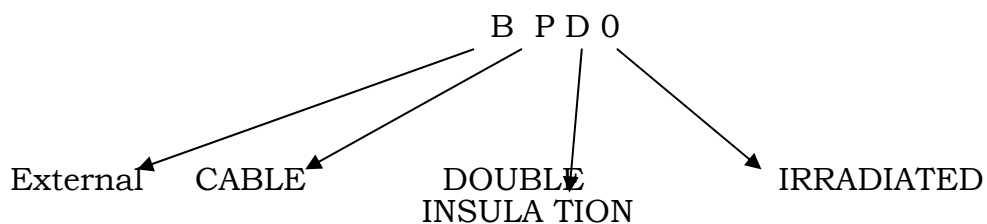

BPDO: Current carrying strands are made of tin plated copper wires with two layers of insulations.

Variants

BPDOU: Same as BPDO with reinforced strands made of alloy/BrKhTsrK wire.

BPDOUE: Same as BPDO with reinforced strands made of alloy/BrKhTsrK wire, with shielding.

Characteristics

Classification : External Non Heat Resistant
Voltage Rating : 750 Volts
Temperature Range :-60 to +105°C
Operational Frequency : 2000 Hz
Conductor : Copper Alloy Mandolin
Insulation :Flouro Plastic, Polyethylene

2.16 Specification: TU 16-505.554-81

Applications: This cable is heat resistant and used in fire control Radar of MIG-29 aircraft.

2.16.1 MPO

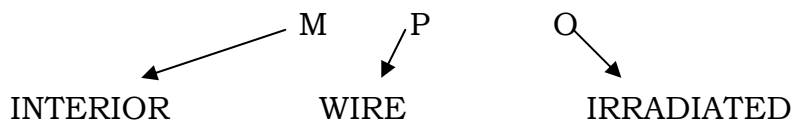

MPO: These are designated earlier as MGTFLE and MGTFLE grades are flexible heat-proof wires insulated by fluroplastic-4 films and braid of lavesan silk coated with varnish. Current conducting core and shielding braid are made of copper annealed wires.

Variants

MPOE - Same as MPO, with shield.

Characteristics

Classification : Internal Heat Resistant Wire
Voltage Rating : 500 Volts
Temperature Range : 60 to + 120°C

Operating Freq : 10000 Hz
 Conductor : Copper Wire
 Insulation : Fluoroplastic

Physical Characteristics : MPO and MPOE wires were earlier designated as MGTFL & MGTFL E grades. Respectively they are 'flexible and heatproof. When these wires are heated up over 250°C, they evolve toxic gases.

2.17 Specification: TU 16-505.324-80

Applications: These wires are flexible and heat proof and are used in the fire control radar of MIG-29 aircraft and infra red of MIG-29 aircraft.

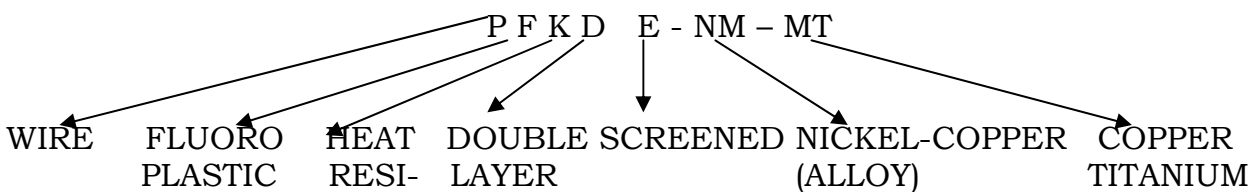

2.17.1 PFKE-NM-MT:

It is a thermo electrode with one strands of nickel copper and another of Copper titanium placed in one sheath.

Variants

PFKE-NM-MT: Same as PFK-NM-MT with shielding

PFKDE-NM-MT: Same as PFKE-NM-MT with double shielding.

PTF - NM - MT & PFK-NM-MT: Are same construction wire

Characteristics

Classification : Thermo Electrode Wire
 Temperature Range : - 60 to + 250°C
 Insulation : Fluoroplastic

2.18 Standard: GOST 24335-80

Application: These wires are used where thermocouples are employed as sensors.

20.

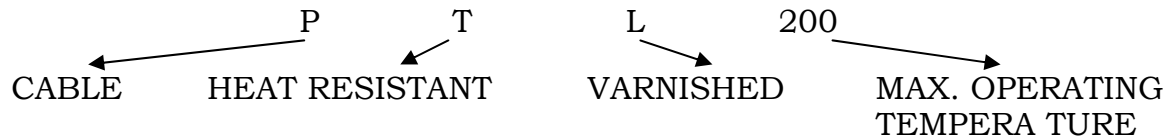

2.18.1 PTL 200

Wires are of tin plated copper conductor, with insulating material polytetra fluoroethylene and glass thread operating temperature is between -60°C to +200°C.

Variants

PTLE-200 : Same as PTL-200, with shielding.

PTL-250 : Same as PTL-200 .Operating temp is between -60°C to +250°C

PTLE-250 : Same as PTL-200 .Operating temp is between -60°C to +2500°C, with shielding.

Characteristics

Classification	: External Heat Resistant
Voltage rating	: 250 Volts
Temperature range	: - 60 to + 200°C
Operational frequency	: 5000 Hz
Conductor	: Tinned Copper
Insulation	: Flouro Plastic, Varnished Fibre Glass Sheath

2.19 Specification TU 16-505.280-79

Applications: This is a heat-resistant cable used in Engine harness, fire protection circuits in engine zone and also in the electrical power circuits.

2.19.1 RK

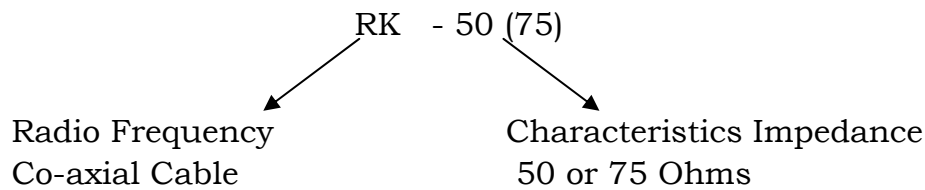

Radio Frequency Co-axial Cable:

These are co-axial cable used for high frequency applications. Characteristic impedance of these cables is either 50 or 75 Ohms. Constructional details o RF cable is as follows:

- (a) Inner Conducto: It is made up of seven copper silver plated wires of nominal diameter of 0.15mm.
- (b)Insulation: Teflon tape continuously wound over inner conductor.
- (c) Outer Conductor: It is a braiding of copper silver plated wires.
- (d) Sheathing: It is of fluoroplastic material. The outer diameter of the cable is 3.2 mm.

Decoding of Part Number: Decoding of part number of RF cables is as follows:

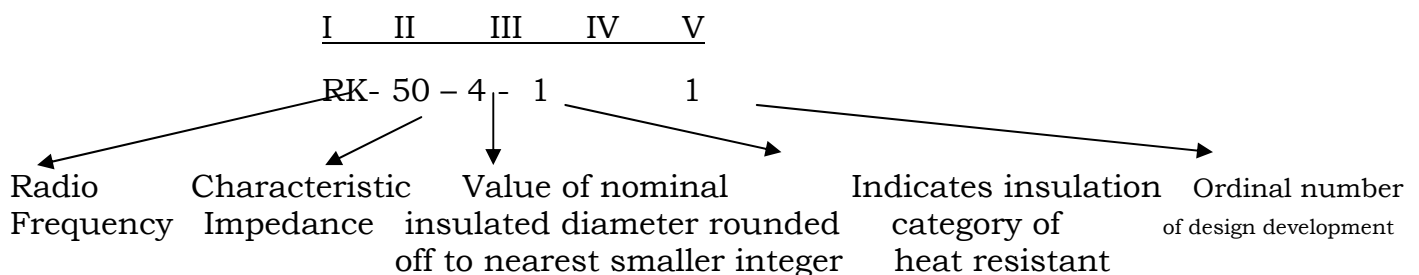

First Place: The first two letters represent type of cable (RK - Radio frequency cable)

Second Place: There are two digits which indicate characteristic impedance in Ohms.

50 - Characteristic impedance 50 Ohms.

75 - Characteristic impedance 75 Ohms.

Third Place: There is a 'number which indicate nominal insulated diameter, rounded off to the nearest smaller integral (whole) number.

Fourth Place: It consists one single digit that indicates insulation group and category of heat resistance. The meaning of the digit is as follows:

- 1- Normally heat-resistant cables with continuous insulation.
- 2- Cables of increased heat stability with continuous insulation.
- 3- Cables of normal heat with semi-air insulation.
- 4- cables of increased heat stability with semi-air insulation.
- 5- Cables of normal heat stability with air insulation.
- 6- Cables of increased heat stability with air insulation.
- 7- Cables of high heat stability.

Fifth Place: There can be one or two digits which indicate ordinal number of the design development.

Thus RK-50-4-11 designates radio frequency coaxial cable with the rated characteristic impedance equal to 50 ohms; with continuous insulation of nonna! heat stability; nominal insulated diameter is equal to 4.6 mm; the ordinal number of the development is 1.

Standard: For RK-50-7-11 - GOST-11326.4-67
For RK-75-4-22 - GOST-11326.43-67

2.20 Comparison of MIL Standard & Russian specifications

Note: This comparison illustration is for a particular cable type only. The TU specifications differ for different type of cable under consideration.

Table 2

Comparison of Properties of TU16-505.083-78 and MIL-DTL-22759/86A, 88A

Sl. No.	Examination or Test	TU16-505.083-78	MIL-DTL-22759/86A, MIL-DTL-22759/88A
1.	Temperature Rating	100°C, 155 °C & 200 °C <i>Table 1 of Specification</i>	200°C for MIL-DTL-22759/86A 150°C for MIL-DTL-22759/88A <i>Refer Specification Sheet</i>
2.	Voltage Rating	100V for MS 16-13, 250V for MS 26-13 & 500V for MS 36-13 <i>Table 1 of Specification</i>	600 V <i>Refer Specification Sheet</i>
3.	Conductor Stranding	0.75 Sq. mm & 35-95 Sq. mm- Class 3 0.2-0.5, 1.25 Sq. mm Class 4 GOST 22483-77 <i>Table 2, 3 and 4 of Specification</i>	As per 'Annexure-A' <i>Refer Table II and 3.5.1.1 of MIL-W-22759E</i>
4.	Insulation Resistance	<i>2.3.3 of Specification</i> 2000 MΩ-Km At 200°C- 100 MΩ-Km for period of operation and storage – 10 MΩ-Km In normal climatic conditions	Min. 1524 MΩ-Km at room temperature <i>Refer Specification Sheet</i>
Sl. No.	Examination or Test	TU16-505.083-78	MIL-DTL-22759/86A, MIL-DTL-22759/88A
5.	Wet Arc Propagation	N.A	MIL-STD-2223 Method 3006 <i>Refer Specification Sheet</i>

	Resistance					
6.	Dry Arc Propagation Resistance	N.A	MIL-STD-2223 Method 3007 <i>Refer Specification Sheet</i>			
7.	Blocking	N.A	200°C+2 °C <i>As per 3.6.6 of MIL-W-22759E</i>			
8.	Color striping or banding durability	N.A	125 Cycles (250 Strokes) <i>As per 3.6.4 of MIL-W-22759E</i>			
9.	Conductor Strand adhesion	N.A	Min. 13 unbounded strands 3.5.1.1.3 <i>of MIL-W-22759E</i>			
10.	Dynamic Cut-through	N.A	ASTM D 3032, Section 22 <i>Refer Specification Sheet</i>			
			Wire Size	23+ 5°C	150± 5°C	200± 5°C
			26	10 lbs	8 lbs	6 lbs
			20	25 lbs	20 lbs	15 lbs
16	25 lbs	20 lbs	15 lbs			
11.	Flammability Test	N.A	MIL-STD-2223 Method 1006, Procedure A <i>Table III of MIL-W-22759E</i>			
a.	Duration of after-flame		3 Seconds (max)			
b.	Flame travel		3.0 inches (max)			
c.	Faming of Tissue		No Flaming			
12.	Forced Hydrolysis	N.A	SAE AS4373 2000 hrs at 70°C <i>Refer Specification Sheet</i>			
13.	High Frequency Spark Test	N.A	MIL-STD-2223 Method 3008 5.7 Kilovolts (rms.) <i>Refer Specification Sheet</i>			
14.	Immersion Test	N.A	MIL-STD-2223 Method 1001 <i>Table III of MIL-W-22759E</i>			
15.	Life Cycle Test	N.A	500 Hrs at 230°C+2°C Dielectric test, 2500V (rms), 60Hz <i>Table III of MIL-W-22759E</i>			
16.	Removability of Insulation	N.A	Insulation shall be readily removable without damage to the conductor			

17.	Identification of product	N.A	RADIANT M-22759/86-16/2009 3.6.5 of MIL-W-22759E
18.	Durability of identification	N.A	Min. 250 strokes 3.6.5.2 of MIL-W-22759E
19.	Mandrel Wrap	N.A	No cracks, No dielectric breakdown at 2500 Volts for 5 minutes 3.6.3 of MIL-W-22759E
20.	Shrinkage	N.A	Test at 230°C±2 °C 2.31mm for 26-10AWG and 3.17mm for 8-04 AWG <i>Refer Specification Sheet</i>
21.	Low Temperature (Cold bend) at -65±2°C	N.A	No cracks, No dielectric breakdown at 2500 Volts for 5 minutes <i>Refer Specification Sheet</i>
22.	Smoke Test	N.A	200°C±2 °C <i>Refer Specification Sheet</i>
23.	Solderability	N.A	Not Required. Primarily intended for crimp terminations 3.6.8 of MIL-W-22759E
24.	Thermal Shock Resistance	N.A	200°C±2°C Max. Change in measurement 2.31mm for 26-10 AWG and 3.17mm for 8-04 AWG. No cracking <i>Refer Specification Sheet</i>
25.	Insulation		
26.	Strippability	N.A	ASTM D 3032 Sec.27 Min. 2 N Max. 32 N <i>Refer Specification Sheet</i>
27.	Thermal Index	10,000 Hrs at 155 °C / 200 °C <i>Table 7 of Specification</i>	200°C min. For MIL-22759/86A 50°C for MIL-22759/88A for 10,000 Hrs, M D3032, Section 14 <i>Refer Specification Sheet</i>
28.	Impulse Dielectric	N.A	8.0 KV peak 3.6.2 of MIL-W-22759E

29.	Bending Radius	5D <i>2.6.3 of Specification</i>	5D
30.	Sinusoidal Vibration	Range of frequency- 1 to 5000Hz Amplitude of speed, m/s ² (g) - 392 (40) <i>2.5.1 of Specification</i>	N.A
31.	Acoustic Noise	Range of Frequency- 50 to 10000Hz at Level of sound pressure 160dB <i>2.5.1 of Specification</i>	N.A
32.	Mechanical Impact of single action	Shock acceleration peak value, m/s ² (g) - 1471(150) Duration of action, ms 1 -3 <i>2.5.1 of Specification</i>	N.A
33.	Mechanical Impact of multiple action	Shock acceleration peak value, m/s ² (g) 9810(1000) Duration of action, ms 0.2-1 <i>2.5.1 of Specification</i>	N.A
34.	Linear Acceleration	4905 (500) m/s ² (g) <i>2.5.1 of Specification</i>	N.A
35.	Reduced Atmospheric Working Pressure	33x10 ⁻⁴ Pa (5mm Hg Column) <i>2.6.4 of Specification</i>	N.A
36.	Increased Atmospheric Working Pressure	295 kPa (3 Kf/cm ²) <i>2.6.7 of Specification</i>	N.A
37.	Breaking strength of high strength strands	2.4 to 2.8 times more than f normal strength strands <i>Point No.3 of Appendix 1 of the Specification</i>	N.A
38.	Maximum temp (short duration for 3 Hrs)	250°C <i>2.6.2 of Specification</i>	N.A

39.	Increased Humidity	Relative humidity at 35°C-98% <i>2.6.9 of Specification</i>	N.A
40.	Salt Fog	For non shielded wires (+) <i>2.6.6 of Specification</i>	N.A
41.	Ultra Violet Total Solar Radiation	Stable, as per GOST 16962-71 <i>2.6.10 of Specification</i>	N.A
42.	Mould Fungus	Max. 2 Marks <i>2.6.5 of Specification</i>	N.A
43.	Service Life Period	15 years Min. <i>2.8.2 of Specification</i>	25 years Min.
44.	Operating Period	100000 Hrs at 100°C, 10000 Hrs at 155°C/200°C, <i>2.8.3 of Specification</i>	10000 Hrs at 200°C

2.21 De-rating Criteria for wires & cables

Table 3
Wire and Cable De-rating criteria as per MIL-STD-975

Wire Size (AWG)	De-rated Current (Amperes)	
	Single Wire	Bundled Wire or Cable
30	1.3	0.7
28	1.8	1.0
26	2.5	1.4
24	3.3	2.0
22	4.5	2.5
20	6.5	3.7
18	9.2	5.0
16	13.0	6.5
14	19.0	8.5
12	25.0	11.5
10	33.0	16.5
8	44.0	23.0
6	60.0	30.0
4	81.0	40.0
2	108.0	50.0
0	147.0	75.0
00	169.0	87.5

Note:

1. De-rated current ratings are based on an ambient temperature of 70°C or less
2. The de-rated current ratings are for 200°C rated wire, such as Teflon insulated (Type PTFE) wire in a hard vacuum of 10⁻⁶ torr.
 - a. For 150°C wire, use 80% of value shown in Table 16.
 - b. For 135°C wire, use 70% of value shown in Table 16.
 - c. For 105°C wire, use 50% of value shown in Table 16.

3. The current rating for bundles or cables is based on bundles of 15 or more wires. For smaller bundles, the allowable current shall be determined by $IBW = ISW \times (29-N)/28$ where N = number of wires, IBW = current, bundled wire and ISW = current, single wire.

CHAPTER III

FAILURE ANALYSIS AND TESTING REQUIREMENTS FOR AIRCRAFT WIRES AND CABLES

3.1 Introduction

It is important to recognize the certification requirements for Aircraft electrical wires & cables and the design standards achieved by aircraft manufacturers especially in relation to fire hazards. Consequently, it is not correct to assume that every cable type in use has a current approval for use on all aircraft.

3.2 Cable Failure analysis

3.2.1 Polyimide insulation can be recognized by its bright translucent copper color. This is often misinterpreted as the conductor being exposed when the topcoat cosmetic layer has been removed due to damage. Although this has not degraded the cable insulating properties, this mottling of the cable does lead to actual chafes being harder to detect amongst flaking lacquer. Complacency can also creep in with tradesmen assuming it is actually flaking lacquer. A considerable amount of flaking is now being exhibited on many aircraft and many man-hours are being expended by electrical tradesmen re-evaluating damage that has already been examined on a previous occasion.

3.2.2 Cracking and splitting of the polyimide insulation is normally found where cable bend radii have been exceeded or excessive flexing of the wires allowed. This form of damage has been found on numerous occasions within weapons pylons. This damage has been accelerated by hydrolysis action within the Severe Wind And Moisture-Prone areas (SWAMP) areas. Once this type of damage has occurred and the conductors are exposed, the looms are in a primed condition for a wet or dry carbon arc track event. There are already occurrences of inadvertent weapons release from the Tornado due to this type of damage.

3.2.3 Polyimide is a tape-wrapped insulation. During manufacture these tapes are sintered together to seal them in place. Experience has shown that flexing and damp conditions allow these tapes to unwrap and exposing the conductors.

Polyimide insulated wires are stiffer than other types of wire and this has proved to be its weakness in fighter aircraft. It is reluctant to move *with* areas of vibration and so chafe

damage is inflicted on the insulation. Due to the volume of wiring on current fighter aircraft, where space is at a premium, cable is susceptible to inadvertent damage by tradesmen removing or fitting equipments. If this minor scuffing is ignored then catastrophic consequences could result.

3.2.3 The problem of fitting more wire into less space now appeared to be solved until the US Navy reported that they were experiencing excessive chafing, cracking and damage to the cable looms, especially in SWAMP area. As these problems appeared to be attributable to a breakdown of the insulation material the US Navy conducted preliminary tests which revealed three potential problems which appeared to be unique to polyimide wire types.

a. **Hydrolysis:** It is a phenomenon characterized by cracking and breakdown of the insulation material through exposure to moisture; the speed of breakdown depending on both temperature and stress.

b. **Wet Arc Tracking:** Carbon arc tracking occurs when contaminating moisture or aircraft fluids create a short circuit between an exposed conductor and the aircraft structure or an adjacent exposed conductor at a different potential.

c. **Dry Arc Tracking:** Carbon arc tracking occurs in dry conditions when one or more conductors are shorted as a result of abrasion from the aircraft structure, wire to wire abrasion, and installation error or battle damage.

The Kapton insulated wire still made this day and flies in over a third of the world's commercial planes. Kapton is best when young. It is feather weight. The salient feature of this insulation is that its thickness of only about three human hairs is flame resistant & tough. But the bad thing is that the Kapton insulation can explode like a firework if it's chafed and rubs against metal. That's called 'dry arcing'. Worse still, salt water or solvent can penetrate the insulation and cause the same problem. That's called 'wet arcing'. Most wires, when they short-circuit, simply spark and blow a fuse. But with Kapton insulation the spark explodes. Inside the confines of the plane, and with alarming speed, this can quickly spread into a lethal weapon of toxic fumes and flames. The following types of failures and quality faults are amongst those seen in recent years.

3.3 Arc Tracking

Airworthiness certification authorities have drawn the attention of Industry to the problem of wet arc tracking of damaged cables subjected to fluid contamination. Wire manufacturers should ensure that hot stamp printing is properly controlled. Therefore, 'Interconnect' and 'Equipment Wires' should not be hot stamp printed.

3.4 Abrasion

Some types of cable have shown a tendency to 'wear through' the insulation at a point where cable rubs on cable or cable rubs on structure. Areas of high vibration induce this failure mechanism and it may be supposed that the stiffer construction of some cables tends to produce a greater contact force and transmit vibration where previously it was damped. Careful cable loom tying and clipping is necessary to alleviate this problem.

3.5 Conductor 'Knuckling Through'

Some earlier cable designs tended to exhibit knuckling of conductors which could be severe enough to penetrate the insulation. This was induced by applying excessive pull through forces and care should be taken not to put cables under tension.

3.6 Red Plague

Cables with silver plated conductors can exhibit the aptly named 'Red Plague' if the plating has been damaged and then exposed to moisture. Consequently, silver plated conductors are generally unsuitable for use in unpressurised areas.

3.7 Glycol Fires

It is known that should De-icing fluid contaminate silver plated conductors, an electrical fire can result. Accordingly, silver plated conductors should not be employed in areas where De-icing fluid can be present.

3.8 Poor Solderability

It should be recognized that the quantity of free tin on plated conductors rapidly reduces with time. The replacement of soldered connections during aircraft maintenance

will probably require that conductors are 'tinned' as part of the process. The loss of free tin starts as soon as the cable is manufactured and hence prolonged storage should be avoided. This indicates the importance of specifying electrical cable of an appropriate type and quality. It is the design intent that the present generation of CEMILAC approved cables should last an airframe life but this will only be achieved if installations are designed and maintained with care and cable selection is made such that operating conditions, especially maximum temperature, seldom if ever, approach the specified limiting parameters.

The data from the visual inspections, nondestructive testing, and laboratory analysis were analyzed to accomplish two objectives:

- a. To evaluate the adequacy of visual inspection for detecting deteriorating wire installations.
- b. To determine the condition of wire in aged aircraft

The intrusive inspection focused on six significant categories of wire degradation. They are as follows.

- i. Degraded wire repairs or splices
- ii. Heat damaged or burnt wire
- iii. Vibration damage or chafing
- iv. Cracked insulation
- v. Arcing
- vi. Insulation de-lamination

3.9 Case studies of electrical cable failures

Case-1

Swiss Air Flight 111 and TWA Flight 800 are examples of two high profile fatal crashes that resulted from faulty electrical wiring. On September 2nd 1998, Swiss Air Flight 111, an MD-11 aircraft crashed off the coast of Nova Scotia in Canada. The aircraft en route from John F. Kennedy (JFK) International Airport, New York to Geneva, Switzerland, crashed into the North Atlantic killing all 215 passengers and 14 crew members. According to the Canadian Transportation Safety Board (TSB): final accident report number A98H0003 dated March 27th 2003, the in flight fire "most likely started from an electrical arcing event that occurred above the ceiling on the right side of the cockpit near the cockpit

rear wall. The arcing of one or more wires in turn ignited the inflammable cover material on nearby thermal acoustic insulation blankets and quickly spread. A segment of electrical cable from the in-flight entertainment network is believed to be associated with one or more of the arcing events.

Case-2

On July 17th 1996, Trans World Airlines (TWA) Flight 800, a Boeing 747-131 crashed in the Atlantic Ocean near East Moriches, New York. The flight was operating as a scheduled international passenger flight from John F. Kennedy (JFK) International Airport New York to Paris, France. All 212 passengers and 18 crew members were killed and the airplane was destroyed. According to the National Transportation Board (NTSB): final accident report number NTSB/AAR-00/03 dated August 23rd 2000, it was determined that the probable cause of this accident was an explosion of the center wing fuel tank (CWT) resulting from ignition of the inflammable fuel/air mixture in the tank. The source of the ignition energy for the explosion could not be determined with certainty, but, of the sources evaluated by the investigation, the most likely source was a short circuit outside of the center fuel tank that allowed excessive voltage to enter it through electrical wiring associated with the fuel quantity indication system.

3.10 Qualification Tests

The following qualification tests are conducted for aircraft wires/cables: -

1. Visual & Physical Conductor Tests
 - 1.1. Conductor Inspection
 - 1.2. Conductor Elongation
 - 1.3. Conductor Resistance (Conductor Continuity)
2. Visual & Physical Finished Wire Tests
 - 2.1. Finished Wire inspection
 - 2.2. Insulation wall thickness and Concentricity
3. Environmental Tests
 - 3.1. Fluid immersion
 - 3.2. Acid resistance
 - 3.3. Humidity resistance
 - 3.4. Flammability

3.5. Fire resistance

4. Mechanical Tests

4.1. Tensile strength and elongation of insulation

4.2. Wrap Test

4.3. Cold Bend

4.4. Wrinkle

5. Electrical Tests

5.1. Spark test of primary insulation /voltage withstand test

5.2. Impulse dielectric

5.3. Insulation resistance

6. Thermal Tests

6.1. Life cycle test

6.2. High temp Endurance

6.3. Thermal Shock

6.4. Insulation shrinkage/expansion

6.5. Lamination sealing

6.6. Blocking

6.7. Smoke

3.11 Qualification Test Details

1.0 Visual & Physical Conductor Tests

1.1. Conductor Inspection

- Method : 5001, 5004, 5005, 5006 of MIL STD 2223
- Purpose : These tests determine the diameter of the conductor after the Insulation has been removed.
- Execution : Determine the conductor diameter by measuring the outer diameter in at least three locations along the length of the stripped conductor. Each measurement shall consist of two micrometer readings taken 90 degrees from each other.
- Specific Apparatus : Micrometer or equivalent device capable of measuring to the nearest 0.0001 inch.

1.2. Conductor Elongation:

- Method : 5002 of MIL STD 2223
- Purpose : This test is used as process control test on the conductors either before application of insulation or after insulation with the insulation removed. The insulation process may affect the elongation and break strength of the conductor.
- Execution : The elongation of the specimen shall be calculated as follows:

$$\text{Percent elongation} = \frac{L - 10}{10} * 100$$

Where:

L = the distance between the bench marks on the specimen immediately after rupture (inches).

- Specific Apparatus : Power driven tensile test machine , Strip chart recorder, Tensile machine grips

1.3. Conductor Resistance (Conductor Continuity)

- Method : 5003 of MIL STD 2223
- Purpose : This test determines the direct current (DC) resistance of the conductor of a wire at a specified reference temperature which is usually 20°C (68°F).
- Execution : Kelvin bridge method or Wheatstone bridge method.

$$\text{Conductor Resistance } \left(\frac{\Omega}{1000 \text{ feet}} \right) = \frac{\text{Measured Resistance in } \Omega}{\text{Sample Length in feet}} * 1000$$

- Specific Apparatus : Resistance measuring device.
Temperature measuring device

2.0 Visual & Physical Finished Wire Tests

2.1 Finished Wire inspection

Method : 6001,6002,6004,6005

Purpose: This test determines the diameter of the finished insulated wire.

2.2 *Insulation wall thickness and Concentricity*

- Method : 6003 of MIL STD 2223
- Purpose : This test determines the wall thickness and insulation concentricity of a finished wire. Concentricity measurements are generally only applied to the insulation of extruded wires.
- Execution : All wall thickness measurements shall be made on cross-sections of the wire specimens using the optical measuring device set at a suitable magnification.

$$\% \text{ Concentricity} = \frac{\text{Minimum wall thickness}}{\text{Maximum wall thickness}} * 100$$

- Specific Apparatus : Optical measuring device capable of reading to the nearest 0.0005 inch, Single-edged razor blade or equivalent cutting tool, Insulation stripping tool with precision-sized blades (if needed).

3.0 Environmental Tests

3.1 *Fluid immersion*

- Method : 1001 MIL STD 2223
 - Purpose : This test determines the ability of a wire to resist degradation when exposed to common fluids the wire may come into contact with during its service life.
 - Execution :
- a) Fluid preparation: Each fluid shall be heated to the temperature specified. Adequate ventilation shall be provided for all fluid fumes.
 - b) Pre-immersion test: Each wire specimen shall have the diameter measured to the nearest 0.0001 inch within the center 12-inch portion according to Finished wire diameter Test
 - c) Immersion test: Each specimen, for each test fluid listed, shall be immersed to within 6 inches of each end for the time and temperature specified. During immersion the radius of bend of the wire shall not be less than 14 nor more than 35 times the specified maximum diameter of the wire under test. Upon removal from the test fluid, the specimen shall be wiped dry and then remain for 1 hour in free air at room temperature. The diameter shall be measured within the same 12-inch section as in Pre-immersion test and compared to the initial diameter. The insulation shall be removed for a distance .5 inch from

each end .of the specimen. The specimen shall then be subjected to the bend test of method 2206 and the wet dielectric test of method 3005 of MIL STD 2223.

Table -3 Test fluids and immersion time

Test Fluid	Test Temperature	Immersion Time
MIL-L-23699, Lubricating Oil , Aircraft Turbine Engine, Synthetic Base, NATO Code Number 0-156	48° to 50°C (118° to 122°F)	20 hours
MIL-H-5606, Hydraulic Fluid, Petroleum Base; Aircraft, Missile and Ordinance	48° to 50°C (118° to 122°F)	20 hours
TT-I-735, Isopropyl Alcohol	20° to 25°C (68°to77°F)	168 hours
MIL-T-5624, Turbine Fuel, Aviation, Grades JP-4, JP-5, and JP-5/JP-8ST.	20° to 25°C (68°to77°F)	168 hours

- Specific Apparatus : Immersion thermometer, an air circulating oven, Micrometer to measure wire diameters within 0.0001 inch.

3.2 Acid resistance

- Method : 1002 of MIL STD 2223
- Purpose : This test determines the ability of a wire to resist degradation when exposed to a strong acid.
- Execution : The test specimens shall be immersed to within 1.50 inches of each end in red fuming nitric acid (specific gravity 1.52) at room

temperature for 8 hours. Adequate ventilation shall be provided for all fumes. Following this acid immersion, the specimens shall be removed and immersed, except for 1.50 inches at each end, for 1 hour in water at room temperature containing 0.5 percent of aerosol or equivalent wetting agent. The specimens in the water solution shall then be subjected to the wet dielectric test of method 3005.

- Specific Apparatus : One Pyrex, stainless steel, or similar inert vessel and sufficient quantity of red fuming nitric acid with a specific gravity of 1.52.

3.3 Humidity resistance

- Method : 1004 of MIL STD 2223
- Purpose : The purpose of this test is to permit evaluation of the properties of materials used in wire as they are influenced or deteriorated by the effects of high humidity and heat.
- Execution : The specimen shall be placed in the test chamber and the temperature and relative humidity raised over a 2-hour period to $70^{\circ} \pm 2^{\circ}\text{C}$ and $95\% \pm 5\%$ and maintained at such for a period of 6 hours. At the end of the 6-hour period, the heat shall be shut off. During the following 16-hour period, the temperature shall drop to 38°C or lower. This shall constitute a cycle (2 hours heating, 6 hours at high temperature, 16 hours cooling). A total of 15 consecutive cycles shall be performed for total test time of 360 hours. No more than 2 hours after the end of the fifteenth cycle, the center 50 feet of the sample shall be subjected to the Insulation Resistance Test of Method 3003 with one foot at each end above the test solution.
- Specific Apparatus : A test chamber capable of maintaining an internal temperature of $70 \pm 2^{\circ}\text{C}$ and an internal relative humidity of 95 ± 5 percent shall be used.
- Failure Criteria : a loss of insulation resistance of the sample

3.4 Flammability

- Method : 1006 of MIL STD 2223

Purpose : The test determines the resistance of burning when exposed to a flame. Burning resistance is a wire insulation measured as the amount of time combustion continues or the distance the insulation burns during or after flame application. This test also evaluates secondary ignition due to burning droplets.

Significance : This test provides a standard laboratory test for evaluating the burning resistance of a wire, but does not simulate most actual service applications.

Execution :

- a) Procedure A (60 flame test): The 24 inch specimen of wire shall be marked at a distance of inches from its lower end to indicate the point for flame application and shall be placed in the specified 60-degree position in the test chamber. The lower end of the specimen shall be clamped in position in the specimen holder and the upper end shall be passed over the pulley of the holder and loaded with sufficient weight to keep the wire taut. With the burner held perpendicular to the specimen and at an angle of 30° from the vertical plane of the specimen, the hottest portion of the flame shall be applied to the lower side of the wire at the test mark. The flame shall be adjusted to provide an all blue conical flame approximately 2 inches high with a temperature of $955^{\circ} \pm 30^{\circ}\text{C}$ ($1751^{\circ} \pm \text{F}$) at its hottest point as measured by a thermocouple pyrometer or equivalent device. A sheet of the facial tissue shall be suspended taut and horizontal 9.50 inches below the point of application of the flame to the wire specimen and at least 0.51 inch from the chamber floor, so that any material dripping from the wire specimen shall fall upon the tissue. The flame shall be applied for 30 seconds and then withdrawn at the end of the 30 seconds.
- b) Procedure B (60 flame test with dielectric test). Perform the same 60 degree flame test as procedure A then subject the tested specimen to the wet dielectric test of method 3005, 'except the time of immersion shall be 5 minutes and the time of exposure to full voltage shall be only 1 minute.

4.0 Mechanical Tests

4.1 Tensile strength and elongation of insulation

Method : 2001 of MIL STD 2223

Purpose : This test provides tensile property data on extruded electrical insulation removed from the wire and is used as a process control test for the extrusion test.

Significance : Tensile properties are useful to determine the ability of the insulation to withstand mechanical stresses it may experience in use. Comparison of tensile Properties before and after environmental or thermal exposure is useful to determine the extent of insulation degradation due to the exposure.

Execution :

Pretest measurements: The length between the bench marks shall be measured to the nearest 0.01 inch. The inner and outer diameters of the straight tube samples or the width and thickness of the dumbbell samples at the reduced area section shall be measured. The cross-sectional area shall be calculated from these measurements.

The specimen shall be placed in the grips of the calibrated tensile test machine and adjusted such that the tension will be distributed uniformly over the cross-section of the specimen. The force shall be applied at a uniform rate of 20 ± 1 inch per minute. After rupture of the specimen, the breaking force and the distance the bench marks were apart at the time of rupture shall be recorded. Repeat the procedure on the other specimens.

$$\text{Tensile Strength (psi)} = \frac{F}{C}$$

F = Breaking Force (pounds)

C = Cross-sectional area of the unstretched specimen in square inches

$$\text{Elongation (percent)} = \frac{(D - G)}{G} * 100$$

D = the distance between the bench marks at the moment of rupture (inches)

G = the distance between the bench marks on the unstretched specimens (inches)

Acceptance Criteria : Average tensile strength & elongation should be within permissible limits.

Specific Apparatus :

- a) Power driven tensile test machine with sample grips attached to a force indicator.
- b) Extensometer, calipers, scale, or other device for accurately measuring the length
- c) Micrometer or equivalent device to determine sample cross-sectional area.

4.2 Wrap Test

Method : 2001 of MIL STD 2223

Purpose : This test determines if a wire is susceptible to cracking when wrapped around a mandrel.

Significance : This test has been applied to many wire types especially over braided or tape wrapped wires. This test or the wrap back test is usually required in the individual wire specification.

Execution : Each specimen of finished wire, with a length of 12 inches plus the additional length required for winding on the mandrel , as specified in individual specification, shall be wound tightly for two close turns around a mandrel of the specified diameter. The winding may be accomplished manually or automatically and shall be in the middle portion of the specimen so that at least six inches of each end shall remain straight. The specimen shall then be removed from the mandrel, examined visually for cracks, and subjected to the wet dielectric test, method 3005.

Acceptance Criteria : No cracks should be observed and acceptance criteria of the wet dielectric test

Specific Apparatus :

4.3 Cold Bend

Method : 2004 of MIL STD 2223

Purpose : This test determines the resistance of a wire to cracking or dielectric breakdown at low temperature while being wrapped around a mandrel.

5.0 Electrical Tests

5.1 Spark test of primary insulation /voltage withstand test

Method : 3001 of MIL STD 2223

Purpose : This method is used as a process control test to determine and remove defects in the primary insulation of insulated wires.

Significance : Presence of a weak spot in the insulation results in a breakdown at that spot. When breakdown occurs, the spark test equipment is designed to stop the wire spooling equipment allowing the operator to remove the defective area of the wire.

Execution : The conductor shall be earth-grounded during the spark test. An earth-ground connection shall be made at both ends of the pay-off and take-up reels, except that, if the wire is tested for continuity and the conductor is one of integral length, the

earth-ground connection need only be made at one end. In any case, the conductor on a reel at which a earth-ground connection is made shall be bonded directly to the earth-ground on the transformer of the spark tester. The entire length of the wire shall be passed through the electrode of the spark tester at the specified voltage and frequency. Electrode length and speed of wire movement shall be such that each length of the insulation is subjected to the test voltage for a minimum of 0.2 seconds. Any portion of the wire showing insulation breakdown shall be cut out of the wire including at least two inches on each side of the fault. The frequency and voltage of the spark shall be specified in the individual specification.

Acceptance Criteria : Report if 100 percent of the wire has been subjected to the in-process spark test and certify that all faults detected were removed as required before application of any outer insulation, jacket, or other material.

Specific Apparatus : a) Spark tester capable of providing an essentially sinusoidal voltage with a transformer of sufficient capacity to maintain the test voltage specified in the individual specification.

b) The electrode shall be a bead chain or fine wire mesh construction capable of providing contact with practically the entire wire insulation surface.

c) A fault signaling device or system shall include a visible signal, a fault recording device, and/or an automatic stop device.

5.2 Impulse dielectric

Method : 3002 of MIL STD 2223

Purpose : This method detects and removes insulation defects in finished wires.

Significance : The test is primarily used as a 100 percent screening test at final packaging, but may be used as an in-process test or as an incoming inspection test by the user.

Execution: The finished wire shall be threaded through the electrode head and the conductor shall be grounded at one or both ends. The electrode shall be energized to the specified peak potential and after final adjustment of the voltage with wire in the electrode head, the wire shall be passed from the pay-off spool through the electrode and onto the take-up spool. The speed of passage of the wire through the electrode shall be such that the wire is subjected to neither less than 3 nor more than 100 pulses

at any given point. Any dielectric failures which occur shall be cut out or marked for later removal along with at least 2 inches of wire on each side of the failure. During all parts of the test, including string-up of new lengths, every effort shall be made to test the entire length, including ends of the wire, in accordance with this procedure. All ends or other portions of the wire not so tested shall be removed subsequent to the test. When specified, dielectric failures, untested portions of wire, or portions which have been exposed to fewer or more than the specified number of pulses may be marked by stripping the insulation or by other suitable method of marking as specified in the contract in lieu of being cut out of the wire.

Acceptance Criteria : Report if 100 percent of the wire has been subjected to the impulse dielectric test and certify that all faults detected were removed or marked as required.

Specific Apparatus :

- a) Test impulse - The waveform of the voltage supplied to the electrode head shall consist of a negative pulse, the peak magnitude of which shall be as specified for the wire under test, followed by a damped oscillation.
- b) Instrument voltmeter - Connected to the electrode head, there shall be a peak reading voltmeter indicating continually the potential of the electrode.
- c) Failure detection circuit

5.3 *Insulation resistance*

Method : 3003 of MIL STD 2223

Purpose : This test determines the insulation resistance of a finished wire sample.

Significance : Insulation resistance is of interest in high impedance circuits and as a measure of quality control of the insulation process. Changes in insulation resistance may indicate deterioration in other properties of the wire

Execution : The test specimen shall be immersed within approximately six inches of each end in a water bath containing 0.5 to 1.0 % of an anionic wetting agent of 5 % by weight sodium chloride at room temperature. After a 4-hour minimum immersion time, the specimen shall be subjected to a potential of 500 volts \pm 10

percent applied between the conductors tied together and the water bath, which serves as the second electrode. The insulation resistance of the specimen shall be measured after one minute of electrification and shall be converted to mega ohms for 1000 feet as follows:

$$\text{Resistance} \left(\frac{M\Omega}{1000 \text{ feet}} \right) = \frac{\text{Measured Resistance in } M\Omega}{1000 \text{ feet}} * \text{Immersed length (feet)}$$

- Failure Criteria : Insulation Resistance value below the specified limit
- Specific Apparatus : a) Megaohm Bridge, megaohm meter, insulation resistance test set, or other suitable equipment.
- b) Tub, jar, or other insulated vessel large enough to hold sufficient water to immerse the specimen length.
- c) Anionic wetting agent or quantity of 5 percent by weight sodium chloride in water.
- d) Test sample shall consist of a wire at least 26 feet in length with the insulation removed for 1 inch at each end. The stripped ends shall be twisted together.

6.0 Thermal Tests

6.1 Life cycle test

Method : Method 4001 of MIL STD 2223

Purpose : This test determines if the wire insulation can withstand a temperature aging test for a time period at a temperature greater than the temperature rating of the insulation. To pass this test, the wire must withstand the bend and wet dielectric tests after the thermal exposure.

Execution : The test oven shall be set and thermally stabilized at the specified temperature of the individual specification. The test oven shall be shut off and allowed to return to room temperature. Each end of the conductor shall be loaded with the test weight required in the individual specification and the central portion of each weighted specimen shall then be bent in a “U” shape over a horizontally placed mandrel of the diameter required. The portion of the insulation between the conductor and the mandrel will be under compression and the conductor will be under tension. The mandrel with the weighted samples shall then be placed in the oven and the oven turned on again. The specimens shall be maintained for the time and at the temperature required. The start of the time period shall be determined as the point in time the test oven re-stabilizes at the specified test temperature. After completion of the air oven thermal exposure, the oven shall be shut off, the door opened, and the specimens allowed to cool to room temperature, in the oven, for at least 1 hour. When cooled, the wire shall be immediately freed from *tension*, removed from the mandrel and straightened. Each specimen shall then be subjected to the bend test of method 2006 followed by the wet dielectric test of method 3005.

Acceptance Criteria : same as that of the bend and wet dielectric test.

Specific Apparatus :

- a. Air circulating test oven
- b. Test mandrels which may be coated with PTFE to prevent sticking of the wire specimens.
- c. Thermocouple recorder or strip chart recorder to accurately and continuously monitor the chamber *temperature*.

6.2 *High temp Endurance*

Method : Method 4002 of MIL STD 2223

Purpose : This test determines the ability of the insulation of a fire zone or similar wire to resist degradation due to exposure to a high temperature.

Significance : The test is generally applied to fire resistant or similar wire types in lieu of the elevated temperature aging (life cycle) test.

Execution : The wire sample shall be placed in the oven which shall be maintained at 343°C + 3°C (650°F + 5°F). The ends of the specimen shall be run

through the ports of the oven and connected to the current source which may be either AC or DC. The current through the conductor shall be adjusted to stabilize at the certain values for the applicable wire size. When the stabilized oven test temperature and the stabilized conductor current are reached, the initial voltage and current measurements shall be recorded. The current loaded wire shall remain *in* the air oven at an oven temperature of $343^{\circ}\text{C} + 3^{\circ}\text{C}$ ($650^{\circ}\text{F} + 5^{\circ}\text{F}$) for a period of 100, +1, -0 hours. The current through the conductor shall be checked periodically and maintained at the required test value. At the end of the 100-hour period, while still at the stabilized temperature and conductor current, final voltage and current measurements shall be recorded. Change in resistance during the conditioning period shall be calculated from the voltage and current measurements. The wire shall then be cooled to room temperature and examined for visual defects. Change in color of the finished wire or printed identification shall not be considered a defect. The ends of the wire sample that were outside the oven during conditioning shall be discarded. From the wire which was inside the oven during conditioning, the following 3 foot specimens shall be cut for further testing: viz. bend test followed by wet dielectric test and fluid immersion test followed by bend test and wet dielectric test

Acceptance Criteria : Same as that of conductor resistance bend and wet dielectric tests, fluid immersion tests, and any visual defects observed.

Specific Apparatus :

1. Air oven capable of maintaining a temperature of $343^{\circ}\text{C} + 3^{\circ}\text{C}$ ($650^{\circ}\text{F} + 5^{\circ}\text{F}$).
The oven shall have test ports to allow the sample leads to be connected to a power supply.
2. AC or DC constant current power supply
3. Voltmeter.
4. Ammeter.
5. Fluids as specified in the individual specification.
6. Test mandrels as required.
7. Load weights as required.

6.3 Thermal Shock

Method : Method 4004 of MIL STD 2223

Purpose : This test determines the ability of wire insulation to *resist* shrinkage or expansion due to a brief exposure to temperature extremes.

Significance : This test helps to measure inherent stresses in the insulation which affect longitudinal changes in the insulation.

Execution : The specimen shall be placed in the oven or hot chamber preheated to the specified temperature for 30 minutes. The specimen shall be removed from the oven or hot chamber and within two minutes placed in the cold chamber precooled to $-55^{\circ} \pm 2^{\circ}\text{C}$ ($-67^{\circ}\text{F} \pm 3.6^{\circ}\text{F}$) for 30 minutes unless otherwise specified. After 30 minutes the cycle – (hot, room, then cold temperatures) shall be repeated. A total of 4 full cycles shall be performed.

At the conclusion of the 4th cycle, the distance from the end of each layer of the insulation to the end of the conductor shall be measured to the nearest 0.001 inch on each end of each specimen. The difference in the length of exposed conductor before and after the test shall be calculated. The insulation shall also be checked for flaring of any layer.

Acceptance Criteria : No change in length of exposed conductor *on* each end of each specimen and flaring of any layer of the insulation.

Specific Apparatus :

1. Suitable thermal shock chamber or combination of an air oven and cold chamber capable of maintaining the specified temperatures and tolerance.
2. Timers to measure cycle times.
3. Scale to measure shrinkage/expansion to the nearest 0.001 inch.
4. Razor blade or equivalent sharp cutting tool.

6.4 Insulation shrinkage/expansion

Method : 4005

Purpose : This test determines the ability of wire insulation to resist shrinkage or expansion due to a brief exposure to a high temperature.

Significance : This test helps to measure inherent stresses in the insulation which affect longitudinal changes in the insulation.

Execution : The oven shall be thermally stabilized then the specimen shall be placed in the oven at the specified temperature for 6 hours. After 6 hours, remove the specimens from the oven and allow the specimens to return to room temperature. The distance from the end of each layer of the insulation to the end of the conductor shall be measured to the nearest 0.001 inch on each end of each specimen. The difference in the length of exposed conductor before and after the test shall be calculated.

Acceptance Criteria : the change in length of exposed conductor on each end of each specimen should be within the permissible limits.

Specific Apparatus :

- a. Suitable air oven capable of maintaining the specified temperatures and tolerance.
- b. Timer to measure exposure.
- c. Scale to measure shrinkage/expansion to the nearest 0.001 inch.
- d. Razor blade or equivalent sharp cutting tool.

6.5 Lamination sealing

Method : 4006 of MIL STD 2223

Purpose : This test determines if tape wrapped insulations have been properly processed.

Significance : Failure of this test indicates the layers of tape are properly sealed and have too little adhesion between their layers.

Execution : The specimens shall be maintained at the temperature specified for 48 hours in an air oven. At the end of this period, the specimen shall be removed from the oven and allowed to return to room temperature. The specimen shall then be visually examined for de-lamination. De-lamination is defined as separation of layers or lifting of tapes along the insulation or at the ends.

Acceptance Criteria : no de-lamination noticed

Specific Apparatus : Air circulating oven capable of maintaining the temperature and tolerance specified.

6.6 Blocking

Method : 4007

Purpose : This test determines if a wire will block (stick to itself) after exposure to a short time thermal exposure.

Significance :

Execution : One end of the specimen shall be affixed to a metal spool or mandrel of the specified diameter. The wire shall then be wound helically at the tension shown for the wire size for at least three turns, with the succeeding turns in close contact with one another. The winding shall be continued until there are at least three closely-wound layers of such helical turns on the spool. The free end of the wire shall then be affixed to the spool or mandrel to prevent unwinding or loosening of the turns. The spool or mandrel with the attached wire specimen shall be placed for 24 hours in an air oven at the temperature specified. At the end of 24 hours the spooled wire shall be removed from the oven and allowed to come to room temperature. The wire shall be unwound from and examined for adhesion (blocking) of adjacent turns.

Acceptance Criteria : No adhesion (blocking) of adjacent turns noticed

Specific Apparatus :

- a. Metal spool or mandrel of the specified diameter.
- b. Clamps or other means to secure the wire to the spool or mandrel.
- c. Air oven to maintain the temperature and tolerances specified.

6.7 Smoke

Purpose : This test determines if the insulation of a wire will produce smoke when the conductor is subjected to an overload current which raises the conductor temperature to the rated temperature of the insulation.

Execution : This test shall be conducted at room ambient temperature in still air. The specimen shall be suspended so that at least the central 10-foot section is horizontal and unsupported. One end of the wire shall be suitably weighted so that no sagging will occur. The resistance of the central 10-foot section shall be measured in accordance with Method 5003 (Conductor Resistance). During the test, while passing direct current through the wire to raise its temperature, the voltage drop shall be measured over the 10-foot section. The voltage-to-current ratio (resistance) needed to provide the required smoke test temperature specified in the individual specification

Appendix – A

List of Type Approvals

1.	Type Approval No.	:	9
2.	Approval Title	:	High Temperature Electrical Cables
3.	Validity of Approval	:	28 May 1971
4.	Developer of the Item	:	M/s Garg Associates Pvt. Ltd., Ghaziabad, U.P
5.	Governing Specification	:	MIL-W-16878D (Navy)
6.	End Use of the Item	:	Aircraft use
7.	Other Details	:	<ul style="list-style-type: none"> a) Wire electrical type EE 200°C 18 AWG (7/26) Red - 1000 V b) Wire electrical type EE 200°C 28 AWG (7/36) Violet - 1000 V c) Wire electrical type E 200°C 20 AWG (19/32) Black - 600 V d) Wire electrical type ET 200°C 24 AWG (7/32) Green - 250 V

1.	Type Approval No.	:	10
2.	Approval Title	:	Tinned Copper Flexible Cable Braids
3.	Validity of Approval	:	28 May 1971
4.	Developer of the Item	:	M/s Metal Cloth Products Bangalore
5.	Governing Specification	:	QQ-B-575
6.	End Use of the Item	:	Aircraft use
7.	Other Details	:	<ul style="list-style-type: none"> a) Type 12/5/.0048 (IND) b) Type 24/10 /.005 (IND) c) Type 2X24X16/0.01 (IND)

1.	Type Approval No.	:	12
2.	Approval Title	:	Nyvin Type Electrical Cables- 16,18,20 & 22
3.	Validity of Approval	:	24 Jul 1971
4.	Developer of the Item	:	M/s. Henley Cables India Ltd., Poona-1
5.	Governing Specification	:	BS: G-177/MAR 1961
6.	Characteristics of Wire		
	a) Voltage Proof Test	:	2000 V AC RMS
	b) Insulation Resistance	:	≥ 200 MΩ
	c) Temperature Range	:	-40 ⁰ C to +55 ⁰ C
7.	End Use of the Item	:	Aircraft use

1.	Type Approval No.	:	14
2.	Approval Title	:	Flexible Nylon Strapping CATNO.SC-1 & Moulded Studs CATNO.SS3
3.	Validity of Approval	:	31 Dec 1980
4.	Developer of the Item	:	M/s Mayfair Electricals Calcutta - 7
5.	Governing Specification	:	-
6.	End Use of the Item	:	Aircraft use

1.	Type Approval No.	:	15
2.	Approval Title	:	Unipren Type Electrical Cables
3.	Validity of Approval	:	31 Dec 1980
4.	Developer of the Item	:	M/s Henley Cables India Ltd., Poona - 1
5.	Governing Specification	:	BS 2E-21/1957
6.	End Use of the Item	:	Aircraft Use
7.	Other Details	:	- Unitpren 4,6,9 & 12 - Unipren 18,24, 35, 50, 70 & 100

1.	Type Approval No.	:	23																
2.	Approval Title	:	Flexible Nylon Cable Strapping 12.5mm CAT No.SC-2 and Moulded Stud CAT No. SS4																
3.	Validity of Approval	:	25 May 1972																
4.	Developer of the Item	:	M/s Mayfair Electricals Calcutta - 7																
5.	Governing Specification	:	-																
6.	Characteristics of Strap	:	<table border="0"> <tr> <td>2. (a) Breaking Strength</td> <td>not less than 40 lbs</td> </tr> <tr> <td>(b) Elongation at break.....</td> <td>100 ± 10 per cent</td> </tr> <tr> <td>(c) Tear strength with 3/32" dia pin</td> <td>not less than 40 lbs</td> </tr> <tr> <td>(d) Tear strength using studs Cat No SS4</td> <td>not less than 20 lbs</td> </tr> <tr> <td>3. Tests on specimen oil aged at 70°C for 70hrs using hydraulic fluid (MFD 585)</td> <td></td> </tr> <tr> <td>(a) Breaking strength</td> <td>not less than 40 lbs</td> </tr> <tr> <td>(b) Elongation at break</td> <td>75 ± 10 per cent</td> </tr> <tr> <td>(c) Tear strength with 3/32" dia pin</td> <td>not less than 40 lbs</td> </tr> </table>	2. (a) Breaking Strength	not less than 40 lbs	(b) Elongation at break.....	100 ± 10 per cent	(c) Tear strength with 3/32" dia pin	not less than 40 lbs	(d) Tear strength using studs Cat No SS4	not less than 20 lbs	3. Tests on specimen oil aged at 70°C for 70hrs using hydraulic fluid (MFD 585)		(a) Breaking strength	not less than 40 lbs	(b) Elongation at break	75 ± 10 per cent	(c) Tear strength with 3/32" dia pin	not less than 40 lbs
2. (a) Breaking Strength	not less than 40 lbs																		
(b) Elongation at break.....	100 ± 10 per cent																		
(c) Tear strength with 3/32" dia pin	not less than 40 lbs																		
(d) Tear strength using studs Cat No SS4	not less than 20 lbs																		
3. Tests on specimen oil aged at 70°C for 70hrs using hydraulic fluid (MFD 585)																			
(a) Breaking strength	not less than 40 lbs																		
(b) Elongation at break	75 ± 10 per cent																		
(c) Tear strength with 3/32" dia pin	not less than 40 lbs																		
7.	End Use of the Item	:	Aircraft use																

1. Type Approval No. : **48**
2. Approval Title : Tinned Copper Flexible Cable
3. Validity of Approval : 30 Jun 2014
4. Developer of the Item : M/s Metal Cloth Products Pvt Ltd.,
Bangalore – 560 025
5. Governing Specification : QQ-B-575
6. End Use of the Item : Aircraft use
7. Other Details : a) Type 12/5/0.0048" (IND)
b) Type 24/10 /0.005" (IND)
c) Type 2 X 24 X 16/0.01" (IND)
d) Type 24/4 /0.006" = p3 X 6
e) Type 24/8 /0.006" = p6 X 12
f) Type 24/8 /0.0076" = p12 X 16
g) Type 24/8 /0.0116" = p16 X 24
h) Type 24/8 /0.0116" = p24 X 30

Bra
ids

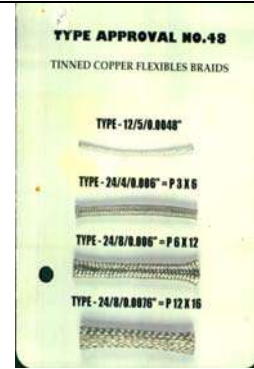

8. **Nominal Wire Size (Standard Wire Gauge)**

Braid Size (Nominal Inside Diameter)	33 Gauge (0.01inch)		36 Gauge (0.0076 inch)		38 Gauge (0.006 inch)		40 Gauge (0.0048 inch)	
	Inch	No. of Carriers	No. of ends	No. of Carriers	No. of ends	No. of Carriers	No. of ends	No. of Carriers
1/32							24	24
1/16			16	16	16	32	24	48
5/64							24	72
7/64			16	32	16	64	24	96
1/8			24	48	24	72	24	120
5/32							24	240
11/64			24	72	24	120	24	168
13/64			24	120	24	192	24	312
1/4							24	344
1/4							24	384
9/32	24	120						
3/8	24	86						
3/8	24	96						
3/8	24	168						
3/8			48	144	48	240	48	384
7/16	24	240						
1/2	24	360						
1/2			48	192	48	336	48	528
9/16	48	480						
21/32	48	768						
25/32			48	336	48	524	48	864

1.	Type Approval No.	:	49
2.	Approval Title	:	Unipren & Uninyvin Cable & Uniflexpren-6
3.	Validity of Approval	:	28 Oct 1974
4.	Developer of the Item	:	M/s Western Insulated Cables Ltd., Poona-1
5.	Governing Specification	:	i) 2E, 21- Dec 1957 (PREN) - British Standard Specifications i) G-177, Mar 1961 (Nyvin) - British Standard
6.	End Use of the Item	:	Aircraft use
7.	Other Details	:	<p><u>Unipren type electrical cables:</u></p> <p>Group 1. Cable Sizes - 4, 6, 9 & 12 Group 2. " " - 18, 24, 35, 50 & 100 Group 3. " " - 135, 150, 170, 200, 230 & 280 Group 4. " " - Uniflexpren - 6</p> <p><u>Uninyvin type electrical cables:</u></p> <p>Group 2. Cable Sizes - 12 & 14 Group 3. Cable Sizes - 2, 4, 6, 8 & 10</p>

1.	Type Approval No.	:	72
2.	Approval Title	:	Uninyvinmet Cables 14, 12, 10 & 8
3.	Validity of Approval	:	30 Dec 1980
4.	Developer of the Item	:	M/s Western Insulated Cables Ltd., Poona-1
5.	Governing Specification	:	BSG 177: 1961
6.	End Use of the Item	:	Aircraft use

1.	Type Approval No.	:	81
2.	Approval Title	:	Uninyvin Type Electrical Cables 22, 20, 18 & 16
3.	Validity of Approval	:	17 Dec 1975
4.	Developer of the Item	:	M/s Western Insulated Cables Ltd., Poona-1
5.	Governing Specification	:	BSG 177: 1961
6.	Characteristics of Wire		
	a) Conductor	:	Annealed Tinned Copper Wires
	b) Insulation	:	White, High Temperature PVC
7.	End Use of the Item	:	Aircraft use

1.	Type Approval No.	:	140	
2.	Approval Title	:	Braided Wire for Electrical Bonding	
3.	Validity of Approval	:	30 Jun 2014	
4.	Developer of the Item	:	M/s Metal Cloth Products Pvt. Ltd., , Bangalore – 560 025	
5.	Governing Specification	:	Technical Specification QQB-575 ETS No.1, Issue-1 dated 18 July 1974	
6.	Characteristics of Wire			
	a) Conductor	:	Tin coated Copper braid	
	b) Temperature Range	:	?	
7.	End Use of the Item	:	Artouste IIIB Engines	
8.	Other Details	:	Part Nos. a) 9.554.81.415.2 / H b) 9.554.81.424.2 / H c) 9.552.11.200.2 / H d) 9.552.11.202.2 / H e) 9.552.11.203.2 / H f) 9.552.81.100.2 / H	

1.	Type Approval No.	:	380
2.	Approval Title	:	Para Mini Flex & Para Mini Flexmet Cables of sizes 0.35, 0.75, 1.0, 1.5 and 2.5 mm² As substitute for USSR Grade DPVLM & BPVLM
3.	Validity of Approval	:	03 Jan 1992
4.	Developer of the Item	:	INCAB Industries Limited Pune - 411013
5.	Governing Specification	:	a) TU-16-505.911-76 b) TU-72-72-06 (III Edition)
6.	Characteristics of Wire		
	a) Classification	:	External Non-Heat Resistant
	b) Voltage Rating	:	500 Volts
	c) Operating Frequency	:	Up to 2000 Hz
	d) High Voltage Withstand (Normal Condition)	:	3500V, 50 Hz for one minute
	e) Insulation Resistance	:	> 500 MΩ / Mtr
	f) Conductor	:	Tinned Copper
	g) Insulation	:	PVC insulation (Vinylchloride)
	h) Temperature Range	:	-60 ⁰ C to +70 ⁰ C
7.	End Use of the Item	:	Different grades of these wires are used in different Aircraft systems such as internal lighting, fuel and power systems. BPVLM cables are combustible but durable to oil petrol mixture.

1.	Type Approval No.	: 421
2.	Approval Title	: Aircraft Cables PRANYVIN PT.No.500, 600 & 700
3.	Validity of Approval	: 30 Jun 1999
4.	Developer of the Item	: INCAB Industries Limited Pune - 411013
5.	Governing Specification	: i) AIR 4524E. 1955 ii) AIR 4524E, 1980 iii) BSG 212, Mar 1971 iv) BSG 222
6.	Characteristics of Wire	
	a) Classification	: Non-flammable, Aero fluid resistant
	b) Voltage Rating	: 600 Vrms
	c) Operating Frequency	: -
	d) Conductor	: Tinned annealed Electrolytic Copper – Type 500 Tinned or Nickel plated annealed electrolytic copper – Type 600 Nickel plated annealed electrolytic copper – Type 700
	e) Insulation	: PVC Insulation – Type 500 FEP or PTFE – Type 600 Sintered PTFE – Type 700
	f) Temperature Range	: -40 ⁰ C to +105 ⁰ C: Peak +135 ⁰ C – Type 500 -50 ⁰ C to +140 ⁰ C: Peak +170 ⁰ C – Type 600 -50 ⁰ C to +275 ⁰ C – type 700
7.	End Use of the Item	: Aircraft use

1. Type Approval No. : **515**
2. Approval Title : **Tinned copper Flexible Cable Braids**
3. Validity of Approval : **31 Dec 2014**
4. Developer of the Item :
M/s Metal Cloth Products (P) Ltd., , Bangalore – 560 025
5. Governing Specification : QQ-B-575
6. Characteristics of Braid
 - a) Conductor : Tin coated copper braid
7. End Use of the Item : For aircraft use
8. Other Details : Type Nos. of the items
 - a) Type 16/7/0.2TC Equivalent to TTC - 4
 - b) Type 24/6/0.2TC Equivalent to TTC - 6
 - c) Type 24/8/0.2TC Equivalent to TTC - 8
 - d) Type 24/8/0.25TC Equivalent to TTC - 10
 - e) Type 32/7/0.25TC Equivalent to TTC - 12
 - f) Type 32/8/0.25TC Equivalent to TTC - 15
 - g) Type 32/10/0.25TC Equivalent to TTC - 19

TABLE - I

NOMINAL WIRE SIZE

Braid size (Nominal inside dia)	0.2 mm Strands		0.25 mm Strands	
	No. of carriers	No. of Ends	No. of carriers	No. of Ends
4	16	112	-	-
6	24	144	-	-
8	24	192	-	-
10	-	-	24	192
12	-	-	32	224
15	-	-	32	256
19	-	-	32	320

1.	Type Approval No.	:	533
2.	Approval Title	:	Indigenous Aircraft Cables 12 Types
3.	Validity of Approval	:	30 Jun 1999
4.	Developer of the Item	:	INCAB Industries Limited Pune - 411013
5.	Governing Specification	:	a) AIR 4524E, 1955 Issue b) AIR 4524, 28 Aug 1980 issue c) BSG 212 Mar 71 d) BSG 222
6.	End Use of the Item	:	For aircraft use
7.	Other Details	:	Part Nos. of 12 type cables i. Paranyvinmetsheath, Part No. 500 H/1 ii. Duparanyvinmetsheath, Part No. 500 H/2 iii. Triparanyvinmetsheath, Part No. 500 H/3 iv. Quadraparanyvinmetsheath Part No. 500 H/4 v. Paranytefmesheath, Part No. 600 H/1 vi. Duparanytefmesheath, Part No. 600 H/2 vii. Triparanytefmesheath, Part No. 600 H/3 viii. Quadraparanytefmesheath, Part No. 600 H/4 ix. Paratefmesheath, Part No. 700 H/1 x. Duparatefmesheath, Part No. 700 H/2 xi. Triparatefmesheath, Part No. 700 H/3 xii. Quadraparatefmesheath, Part No. 700 H/4

AEROSPACE CABLES : TYPE - PARANYVIN METSHEATH T-105

CONFORMING TO AIR 4524E - 1980

L13F

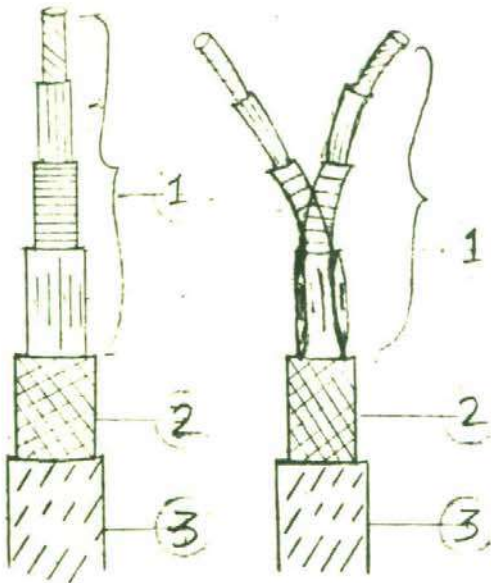

CONSTRUCTION :

1. Single core or several PARANYVIN T-105 cores, Colour coded and twisted together in multicore cables.
2. A Helical braided screen made of tinned annealed electrolytic copper wires (62% minimum coverage.)
3. A smooth protective polyamide (nylon) sheath.

MAIN CHARACTERISTICS :

PARANYVIN METSHEATH T-105 Cables are suitable for all the characteristics of PARANYVIN T-105 cores; the overall polyamide sheath provided will have the following advantages :-

- a) Efficient protection of the screen against oxidation and corrosion.
- b) Good mechanical protection of the screen.

PARANYVIN T-105 CORES						SCREEN AND PROTECTION		
No. of cores	US AWG	Sectional area of conductor Sq.mm.	CONDUCTOR		Dia. of cores (Max) mm.	Screen wire Dia. mm.	Maximum overall Dia. mm.	Average weight g/m
			No. of wires	Dia. (Nom) mm.				
1	22	0.40	19	0.15	2.10	0.12	2.95	19
1	20	0.60	19	0.20	2.30	0.12	3.25	23
1	18	1.00	19	0.25	2.60	0.12	3.50	28
1	16	1.20	19	0.30	2.90	0.12	3.80	33
1	14	2.00	37	0.25	3.40	0.12	4.40	43
2	22	0.40	19	0.15	2.10	0.12	4.95	36
2	20	0.60	19	0.20	2.30	0.12	5.50	45
2	18	1.00	19	0.25	2.60	0.12	6.20	55
2	16	1.20	19	0.30	2.90	0.12	6.40	64
2	14	2.00	37	0.25	3.40	0.12	7.60	88
3	22	0.40	19	0.15	2.10	0.12	5.20	44
3	20	0.60	19	0.20	2.30	0.12	5.90	56
3	18	1.00	19	0.25	2.60	0.12	6.10	71
3	16	1.20	19	0.30	2.90	0.12	6.80	84
3	14	2.00	37	0.25	3.40	0.12	8.00	118

AEROSPACE CABLES : TYPE - PARANYFLON METSHEATH T-140
CONFORMING TO AIR 4524E - 1980

L139

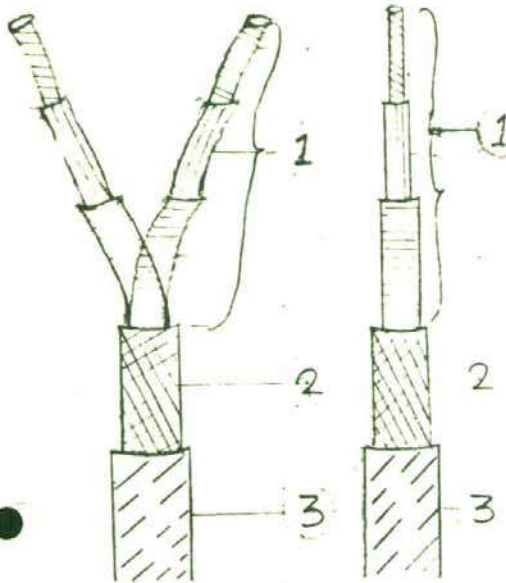

CONSTRUCTION :

1. Single core or several PARANYFLON T-140 cores, Colour coded and twisted together in multicore cables.
2. A Helical screen made of tinned annealed electrolytic copper wires (62% minimum coverage.)
3. A protective sheath consisting of a smooth polyamide (Nylon) sheath (0.20 mm wall thickness approximate.)

MAIN CHARACTERISTICS :

PARANYFLON METSHEATH T-140 cables are suitable for all the characteristics of PARANYFLON T-140 cables and the overall polyamide sheath provided, will have the following advantages :

- a) Efficient protection of the screen against oxidation and corrosion.
- b) Good mechanical protection of the screen.

No. of cores	PARANYFLON T-140 CORES					SCREEN AND PROTECTION		
	US AWG	Sectional Area of conductor (Nom) Sq. mm.	CONSTRUCTION			Screen wire Diameter mm.	Max. Overall Diameter mm.	Average weight g/m
			No. of wires	Diameter (Nom) mm.	Max. Dia. of cores mm.			
1	22	0.40	19	0.15	1.42	0.10	2.30	11.0
1	20	0.60	19	0.20	1.67	0.10	2.50	14.0
1	18	1.00	19	0.25	1.95	0.10	2.70	18.1
1	16	1.20	19	0.30	2.20	0.10	3.00	23.3
1	14	2.00	37	0.25	2.55	0.10	3.30	30.5
2	22	0.40	19	0.15	1.42	0.10	3.80	23.8
2	20	0.60	19	0.25	1.67	0.10	4.10	27.6
2	18	1.00	19	0.25	1.95	0.12	4.50	38.7
2	16	1.20	19	0.30	2.20	0.12	3.20	52.0
2	14	2.00	37	0.25	2.55	0.12	3.90	65.3
3	22	0.40	19	0.15	1.42	0.10	4.00	27.1
3	20	0.60	19	0.20	1.67	0.12	4.40	38.4
3	18	1.00	19	0.25	1.95	0.12	4.80	50.9
3	16	1.20	19	0.30	2.20	0.12	5.50	66.3
3	14	2.00	37	0.25	2.55	0.12	6.30	88.7

ea/-

AEROSPACE CABLES : TYPE - PARATEF-METSHEATHEX T-200

L13"

CONFORMING TO AIR 4524E - 1980

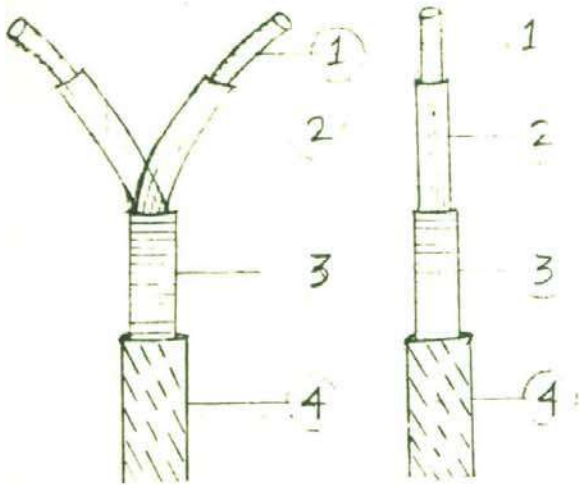

CONSTRUCTION :

1. A stranded conductor made up of Nickel plated annealed electrolytic copper.
2. The insulation shall consist of sintered PTFE.
3. Single core or several cores twisted together.
4. A helical screen made of silver plated copper wires.
5. An extruded FEP sheath.

MAIN CHARACTERISTICS :

- a) Operating Temperature : From -50°C to +200°C; Peak +230°C.
- b) Other characteristics are same as PARATEF T-275 cables.
- c) Good mechanical protection by screen which is resistant to oxidation and with better solderability.

GOVERNING SPECIFICATION :

1. AIR 4524E : Conditions of confirmation and acceptance of simple electric cables for general use.
2. Specn. NFL 52-126 : Electric cables with copper conductor for raised temperature.

No. of cores	US AWG	PARATEF T-275 CORES				SCREEN AND PROTECTION		
		Sectional Area of conductor (Nom) Sq.mm.	CONSTRUCTION			Screen Wire Dia. mm	Max. O/all Dia. mm	Average Weight g/m
			No. of Wires	Dia. (Nom) mm	Dia. of cores (Max) mm			
1	22	0.40	19	0.15	1.42	0.10	2.4	11.9
1	20	0.60	19	0.20	1.67	0.10	2.6	15.1
1	18	1.00	19	0.25	1.95	0.12	2.9	20.1
1	16	1.20	19	0.30	2.20	0.12	3.1	25.8
2	22	0.40	19	0.15	1.42	0.12	3.9	21.6
2	20	0.60	19	0.20	1.67	0.12	4.4	28.9
2	18	1.00	19	0.25	1.95	0.12	5.0	40.4
2	16	1.20	19	0.30	2.20	0.12	5.6	53.6
3	22	0.40	19	0.15	1.42	0.12	4.1	29.6
3	20	0.60	19	0.20	1.67	0.12	4.7	41.4
3	18	1.00	19	0.25	1.95	0.12	5.4	58.8
3	16	1.20	19	0.30	2.20	0.12	5.9	74.6

AEROSPACE CABLES : TYPE - PARATEF-METSHEATH T-275

CONFORMING TO AIR 4524E - 1980

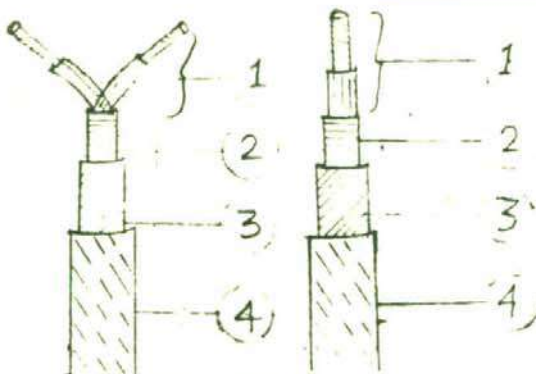

CONSTRUCTION :

1. Single core or several PARATEF T-275 CORES, Colour coded and twisted together in multicore cables.
2. A Helical screen made of nickel plated annealed electrolytic copper wires (62% min. coverage.)
3. A wrapped and fused polyamide sheath.
4. A wrapped and Sintered PTFE.

MAIN CHARACTERISTICS :

PARATEF-METSHEATH T-275 cables are suitable for all the characteristics of PARATEF T-275 cables.

PTFE Sheath provided will have the following advantages :

- a) Efficient protection of the screen against oxidation and corrosion.
- b) Good mechanical protection of the screen.

No. of BS cores	AWG	PARATEF T-275 CORES				SCREEN AND PROTECTION		
		Sectional Area of conductor (Nom)	CONDUCTOR			Screen wire Dia.	Max. Overall Dia.	Average Weight
			No. of wires	Dia. (Nom)	Dia. of cores (Max)			
		Sq. mm.	mm	mm	mm	mm	g/m	
1	22	0.40	19	0.15	1.42	0.10	2.9	13.5
1	20	0.60	19	0.20	1.67	0.10	3.1	17.0
1	18	1.00	19	0.25	1.95	0.12	3.5	23.9
1	16	1.20	19	0.30	2.20	0.12	3.8	28.5
1	14	2.00	37	0.25	2.55	0.12	4.1	37.1
2	22	0.40	19	0.15	1.42	0.12	4.3	29.8
2	20	0.60	19	0.20	1.67	0.12	4.7	37.3
2	18	1.00	19	0.25	1.95	0.12	5.4	41.5
2	16	1.20	19	0.30	2.20	0.12	6.0	58.8
2	14	2.00	37	0.25	2.55	0.12	6.6	76.7
3	22	0.40	19	0.15	1.42	0.12	4.5	36.7
3	20	0.60	19	0.20	1.67	0.12	5.0	47.4
3	18	1.00	19	0.25	1.95	0.12	5.7	63.4
3	16	1.20	19	0.30	2.20	0.12	6.4	77.1
3	14	2.00	37	0.25	2.55	0.12	7.0	103.0

ea/-

1.	Type Approval No.	:	593
2.	Approval Title	:	a) Para Tefmet Sheathex – T200 b) Paranyflon T-140-ATC c) Paranyflon Metsheath T-140
3.	Validity of Approval	:	05 Feb 1993
4.	Developer of the Item	:	INCAB Industries Limited Pune - 411013
5.	Governing Specification	:	a) AIR/4524-E (1980) b) MIL-C-7870T
6.	Characteristics of Wire		
	a) Classification	:	Non-flammable; aero fluid resistant
	b) Voltage Rating	:	600 Vrms
	c) Conductor	:	Nickel plated annealed electrolytic Copper for T200 Tin annealed electrolytic Copper for T-140
	d) Insulation	:	Sintered PTFE for T200 FEP for T-140
	e) Temperature Range	:	-50°C to +200°C: Peak 230 °C for T200 -50°C to +140°C Peak 170 °C for T-140
7.	End Use of the Item	:	For aircraft use
8.	Other Details	:	a) Para Tefmet Sheathex–T200 – NPC Conductor/PTFE INS/ Helical Screen of SPC wires/ FEP Jacket – Size 22 to 16 AWG Single, Twin & Three Cores b) Paranyflon T-140-ATC – ATC conductor /FEP INS/ Polyamidesheath, Size 22 to 10 AWG c) Paranyflon Metsheath T-140 – Paranyflon Core or Cores, Helical Screen of ATC wires & Polyamidesheath, Size 22 to 10 AWG Single, Twin and Three Cores



1.	Type Approval No.	: 667
2.	Approval Title	: Uninyvin Cables
3.	Validity of Approval	: 30 Jun 2001
4.	Developer of the Item	: M/s Jai Bharat Industries New Delhi – 110 020
5.	Governing Specification	: a) BSG-177 b) DTD-1085C
6.	Characteristics of Wire	
	a) Classification	:
	b) Voltage Rating	: 600 Vrms
	c) Operating Frequency	: Up to 1600 Hz (max)
	d) High Voltage Withstand	: 1500 Vrms for one minute
	e) Conductor	: ATC wire
	f) Insulation	: High Temp. PVC
	g) Temperature Range	: -40°C to +105°C
7.	End Use of the Item	: For aircraft use like Chetak, Cheetah, AVRO, Ajeet, Kiran, Canberra, HPT etc.,
8.	Other Details	: Group-I 22 to 16 AWG Group-II 14 to 12 AWG Group-III 10 to 2 AWG Group-IV 1 to 0000 AWG

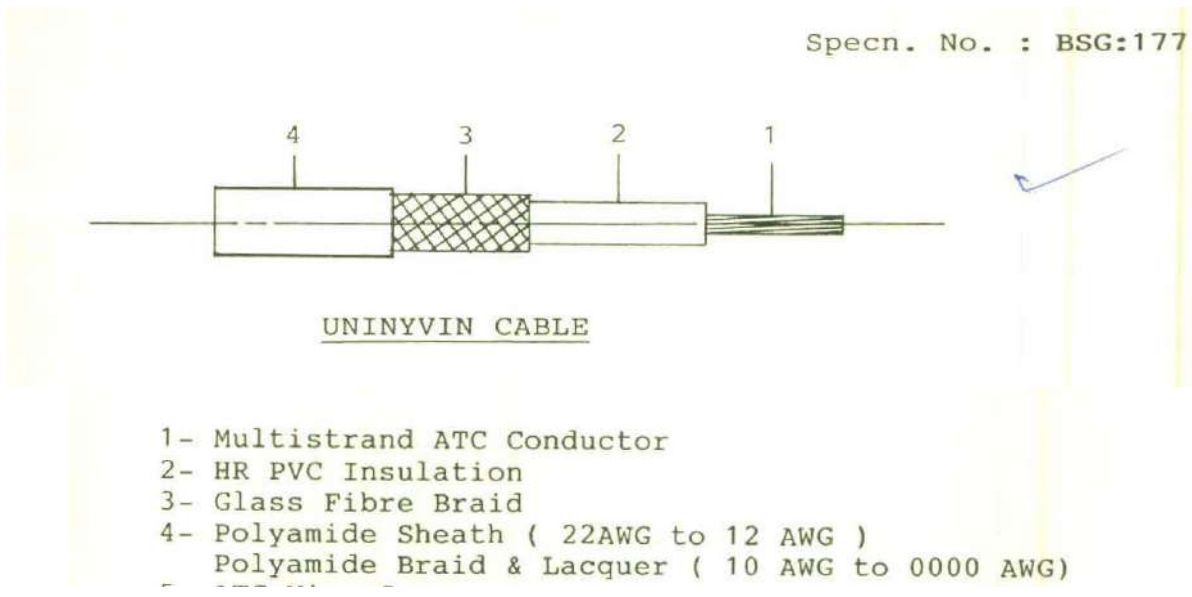

- | | | | |
|----|-------------------------|---|----------------------------------------------------------------------------------------------------------------------------------------------------------------------------------------------------------------------------------------------------------------------------------|
| 1. | Type Approval No. | : | 673 |
| 2. | Approval Title | : | KAPTON Polyimide wires and cables |
| 3. | Validity of Approval | : | 30 Jun 2017 |
| 4. | Developer of the Item | : | M/s Sanghvi Aerospace Pvt Ltd,
Ahmadabad |
| 5. | Governing Specification | : | a) MIL-W-81381/7 & 9 for basic /core
wires
b) MIL-DTL-27500H for cables |
| 6. | Characteristics of Wire | | |
| | a) Classification | : | Internal / External ; heat / wear / thermal resistant wires |
| | b) Voltage Rating | : | 600 V DC |
| | c) Operating Frequency | : | Up to 2000 Hz |
| | d) Conductor | : | Silver plated Copper / Copper Alloy conductor |
| | e) Insulation | : | Polyimide insulation (wrapped) |
| | f) Temperature Range | : | -60°C to +260°C |
| 7. | End Use of the Item | : | In electrical equipments & aircraft electrical wiring harness and
airborne armaments systems |
| 8. | Other Details | : | Sanghvi Aerospace Part No.
381(07/09)-**-▲ (wires) &
381(07/09)-**-s(SK/SKK) (for cables)
is same as
M81381/(07/09)-** (for wires) and
M27500(A/D)**M(R/T)nS(11/12) for cables respectively
(where ** indicates size of conductor, 'n' indicates No. of cores) |



Decoding of Part No. of Wire

◆ **SAPL PART NUMBERING SYSTEM - WIRE**

381XX - ## - *

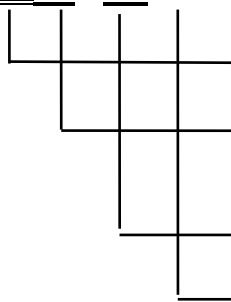

Basic MIL specification identifier
(eg. 381 represents MIL-DTL-81381 specification)

Slash sheet identifier
(eg. 07 represents slash sheet 7 of MIL-DTL-81381 specification)

Gauge size of the conductor in AWG

Colour code designators in accordance with MIL-STD-681

Example : 38107-22-2 = 22 AWG, red colour wire as per MIL-DTL-81381/7

◆ **SAPL PART NUMBERING SYSTEM - CABLE**

381XXX - ## - # XXX

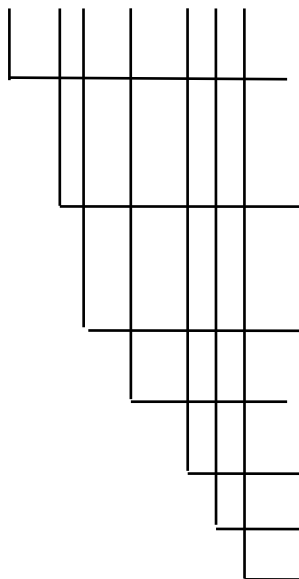

Basic specification identifier

(eg. 381 represents basic core wire as per MIL-DTL-81381 Specification and cables as per MIL-DTL-27500 specification)

Slash sheet identifier

[eg. 07 represents slash sheet 7 of MIL-DTL-81381 (refer Note B)]

Identification method of cable wire, % shield coverage and colour of core wire (Refer Note A)

Gauge size of the conductor in AWG

Number of basic core wires in cable (Refer Note C)

Shield style and material (Refer Note D)

Jacket material (Refer Note E)

Example : 38107D-22-3SKK = 22 AWG, 3 core wire (White, Blue, Orange) as per MIL-DTL-81381/7, Silver plated Copper shielded with 90% coverage, jacket of natural Polyimide tape comBIN/BIN-Ned with FEP having Polyimide as a outer surface and heat sealed

1.	Type Approval No.	:	767
2.	Approval Title	:	Light Weight Series Flexible PTFE, PFA/FEP Insulated Cables Types UNIFLUOR 200BJ (16 AWG & 22 AWG) 2001 (22 AWG) 2501 (16 AWG & 22 AWG)
3.	Validity of Approval	:	30 Jun 1999
4.	Developer of the Item	:	M/s Universal Cables Ltd., SATNA (MP)-485 005
5.	Governing Specification	:	AIR 4524E 1980
6.	Characteristics of Wire		
	a) Classification	:	-
	b) Voltage Rating	:	600 Vrms
	c) Insulation Resistance	:	≥ 500MΩ / km
	d) Construction	:	Unifluor 200BJ - UNISTAR make fluoroelastic flexible screened cables of single, two or three cores of Unifluor type 2001 of sizes 12 AWG to 22 AWG with collective braid of ATC wires and overall jacketed with polyamide Unifluor 2501 - UNISTAR make fluoroelastic flexible screened cable of nickel plated copper conductor, insulated with Teflon PFA for sizes 22 AWG to 12 AWG, single core cable Unifluor 2001 - UNISTAR make fluoroelastic flexible cables of Annealed tinned copper conductor insulated with Teflon FEP and jacketed with Polyamide cables of sizes 24 AWG to 12 AWG, single core
	e) Temperature Range	:	-50 ⁰ C to +250 ⁰ C for Unifluor 200BJ -50 ⁰ C to +250 ⁰ C for Unifluor 2501 -50 ⁰ C to +150 ⁰ C for Unifluor 2001
7.	End Use of the Item	:	For Aircraft use

1. Type Approval No. : **882**
2. Approval Title : **Wire, Electrical, Fluorocarbon Polymer (modified PTFE) / Polyimide insulated, Tin / Silver / Nickel coated copper conductors and cables**
3. Validity of Approval : **30 Jun 2018**
4. Developer of the Item : M/s Sanghvi Aerospace (P)Ltd, Ahmadabad
5. Governing Specification : a) MIL-DTL-22759/80 to 92A for basic/core wire
b) MIL-DTL-27500H for cables
6. Characteristics of Wire
 - a) Classification : Airframe wire
 - b) Voltage Rating : 600 V DC
 - c) Operating Frequency : Up to 2000 Hz
 - d) Dielectric Voltage withstand (between cores) : 1500V RMS for one minute
 - e) Conductor : Tin / Silver /Nickel plated Copper /Copper Alloy
 - f) Insulation : – FP (Modified PTFE) / Polyimide / FP Composite and FP film for wire
– PTFE or FP/PI & FP film for sheath of cable
 - g) Temperature Range : -60⁰C to +200⁰C for SPC (Silver Coated)
-60⁰C to +260⁰C for NPC (Nickel Plated)
-60⁰C to +150⁰C for TPC (Tin Plated)
7. End Use of the Item : In electrical equipments & aircraft electrical wiring harness and airborne armaments systems. Extensively used in HJT-36, LCA and other projects.
8. Other Details :



Decoding of Part No. of Wire

◆ **SAPL PART NUMBERING SYSTEM - WIRE**

759XXX - ## - *

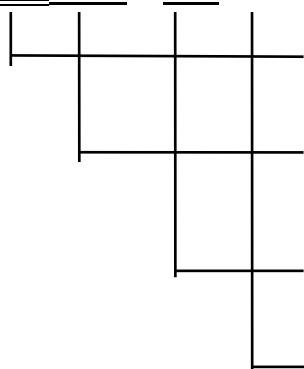

Basic MIL specification identifier
(eg. 759 represents MIL-DTL- 22759 specification)

Slash sheet identifier
(eg. 80A represents slash sheet 80A of MIL-DTL-22759 specification)

Gauge size of the conductor in AWG

Colour code designators in accordance with MIL-STD-681

Example : 75986A-22-9 = 22 AWG White colour wire as per MIL-DTL-22759/86A

◆
◆ **SAPL PART NUMBERING SYSTEM - CABLE**

759XXX - ## - # XXX

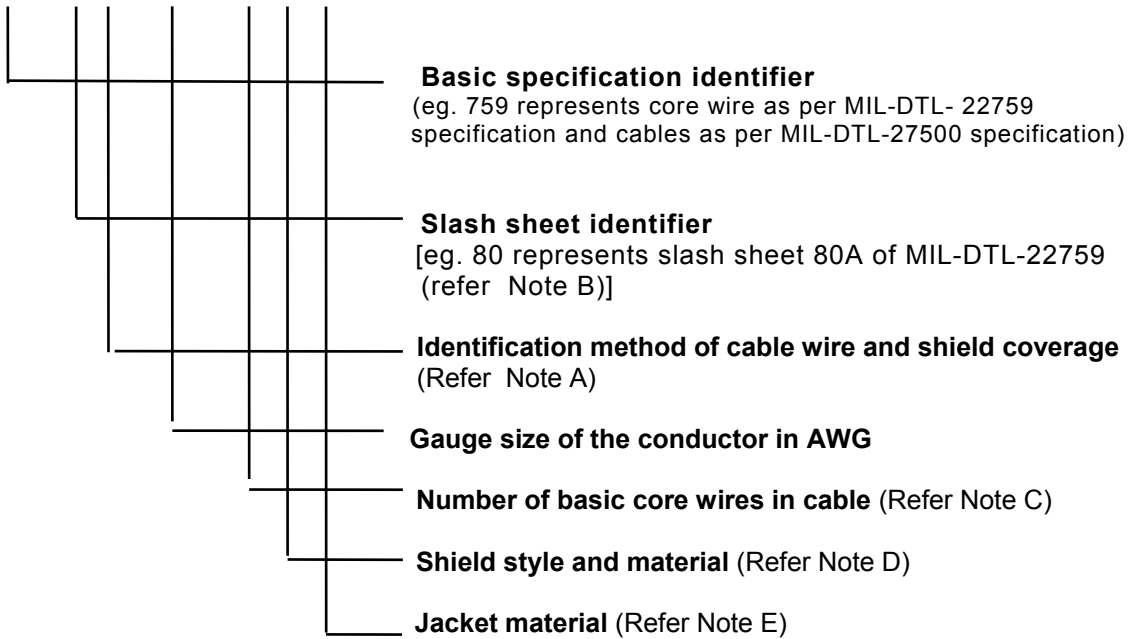

Example : 75986A-22-3S06 = 22 AWG, 3 core wire (White, Blue, Orange) as per MIL-DTL-22759/86A, Silver plated Copper shielded with 85% coverage, taped and heat sealed white PTFE jacketed cable

1. Type Approval No. : **883**
2. Approval Title : **Wires, Electrical, PTFE / Polyimide insulated, light normal weight Tin/Silver/Nickel coated conductors and cables**
3. Validity of Approval : 30 Jun 2003
4. Developer of the Item : M/s. Sanghvi Aerospace Pvt, Ltd. Ahmadabad 382 405.
5. Governing Specification : a) MIL-W-22759/80 to 92 for wires
b) MIL-C-27500 G for Cables
6. Characteristics of Wire / Cable
 - a) Classification : -
 - b) Voltage Rating : 600 Vrms
 - c) Dielectric Withstand Voltage (between core to core & core to shield) : Should withstand 1.5KV for one minute
 - d) Insulation resistance : > 1525 MΩ / km
 - e) Life Cycle Test : 230°C for 500 hrs
 - f) Conductor : Tin/Silver/Nickel coated conductors
 - g) Insulation : PTFE / Polyimide insulation
 - h) Temperature Range : -65 to +150° C for Tin Coated Copper
-65 to + 200°C for Silver Coated Copper / Copper alloy
-65 to + 260°C for Nickel Coated Copper / Copper alloy
7. End Use of the Item : Electrical wires and cables for aircraft harness

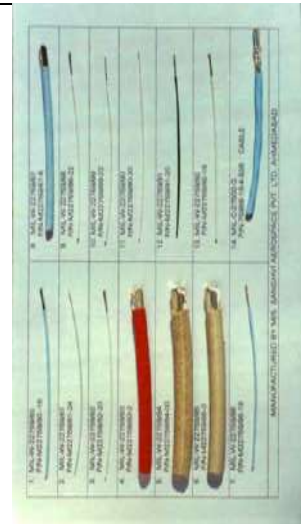

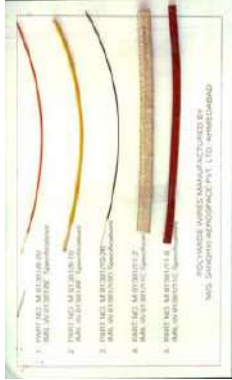
1.	Type Approval No.	:	884	
2.	Approval Title	:	High Tech Polyimide Insulated wires and cables	
3.	Validity of Approval	:	30 Jun 2014	
4.	Developer of the Item	:	M/s. Sanghvi Aerospace Pvt, Ltd. Ahmadabad 382 405.	
5.	Governing Specification	:	a) MIL-DTL-81381/8C,10D &11C, b) MIL-DTL-27500H	
6.	Characteristics of Wire			
	a) Classification	:	Internal / External ; heat / wear / thermal resistant wires	
	b) Voltage Rating	:	600 V DC	
	c) Operating Frequency	:	Up to 2000 Hz	
	d) Conductor	:	Nickel plated Copper conductor	
	e) Insulation	:	Polyimide insulation (wrapped)	
	f) Temperature Range	:	-60°C to +260°C	
7.	End Use of the Item	:	In electrical equipments & aircraft electrical wiring harness and airborne armaments systems	
8.	Other Details	:	Sanghvi Aerospace Part No. 381(08/10/12)-**-▲ (wires) & 381(08/10/12)-**-n(SK/SKK) (for cables) is same as M81381(/08/10/12)-** (for wires) and M27500(A/D)**M(S/V/W)nS(11/12) for cables respectively (where ** indicates size of conductor, 'n' indicates No. of cores)	

1.	Type Approval No.	:	885	
2.	Approval Title	:	High Temperature & High Voltage Ignition Cable Part No. JB-257-0000	
3.	Validity of Approval	:	30 Jun 2013	
4.	Developer of the Item	:	M/s Jai Bharat Industries New Delhi – 110 020	
5.	Governing Specification	:	a) PBCTY Cable TU-OM4-505-003-56 (R11F) b) B3C-350-6.5 Cable TU16-505-236-71 (R-25)	
6.	Characteristics of Wire			
	a) Classification	:	Ignition Cable	
	b) Nominal Impulse voltage	:	Cable shall withstand 15 kV	
	c) Breakdown Voltage	:	≥ 35 kV	
	d) High Voltage test	:	19kV for one minute	
	e) Insulation Resistance	:	10MΩ / mtr	
	f) Resistance of Core	:	2000 Ω / km	
	g) Conductor	:	Stainless Steel Wire of AISI-304 standard	
	h) Insulation	:	PTFE Insulation (Fluro Plastic tape)	
7.	End Use of the Item	:	For use in electrical accessories of R11F & R25 series engines in main manifold and after burner manifold of MiG aircrafts	



1. Type Approval No. : **886**
2. Approval Title : **BIN type wear and heat resistant cables
Part No. JB-777-0035, JB 777-0050, JB 777-0075**
3. Validity of Approval : 30 Jun 2013
4. Developer of the Item : M/s Jai Bharat Industries
New Delhi – 110 020
5. Governing Specification : TY-16-505-620-74
6. Characteristics of Wire
 - a) Classification : Wear and Heat Resistant
 - b) Voltage Rating :
 - c) Insulating Resistance : $\geq 1000\Omega / \text{Km}$
 - d) High Voltage withstanding : 1.5KV, 50 c/s for one minute
 - e) Conductor : Silver plated copper strands
 - f) Insulation : PTFE, fibre glass thread impregnated with suspension of fluoro-plast wrapped and braided with FG thread coated with suspension of fluoro-plast
 - g) Temperature Range : -60 to +250° C
7. End Use of the Item : For use in electrical accessories of R11F, R25, R-29B and RD-33 series engines of MiG aircrafts
8. Other Details

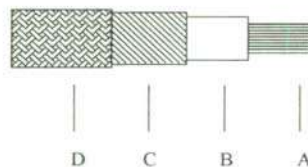

BIN TYPE CABLES
Specn. No. TU-16-505-620-74



Materials	A - Multistrand SPC Conductors B - Fluoroplast-4 insulation C - Impregnated Glass thread/tape with Fluoroplast D - Glass thread braiding with fluoroplast suspension
Item	BIN type cables for Aircrafts
Specn. No.	TU-16-505-620-74
Part Nos.	JB-777-0035, JB-777-0050, JB-777-0075

1.	Type Approval No.	:	889	
2.	Approval Title	:	Polytetrafluoroethylene/Polyimide tape insulated & sintered Electrical Wires & Cables Part No.RW22780 to RW22792- 26 to 04AWG & Cables Part No.RC22792-2UJ to 4UJ/ITJ to 4TJ/ISJ to 4SJ/INJ to 4NJ-26 to 10AWG	
3.	Validity of Approval	:	31 Dec 2013	
4.	Developer of the Item	:	M/s Radiant Cables Limited Hyderabad – 500 018	
5.	Governing Specification	:	a) MIL-W-22759/80-92 b) MIL-C-27500G	
6.	Characteristics of Wire			
	a) Classification	:	Advanced Arc track resistant Normal / light weight	
	b) Voltage Rating	:	600 Vrms	
	c) Insulation Resistance	:	5000 MΩ	
	d) Conductor	:	Standard Tin / Silver / Nickel coated high strength / ultra high strength copper alloy	
	e) Insulation	:	Composite Tape (FP/ Polyimide/FP) and FP tape	
	f) Temperature Range	:	-65 to +150° C for Tin Coated Copper -65 to + 200°C for Silver Coated Copper / Copper alloy -65 to + 260°C for Nickel Coated Copper / Copper alloy	
7.	g) Life Cycle Test	:	500 hrs at 230°C	
8.	End Use of the Item	:	Airborne application inclusive of Naval Air platforms. Like LCA, Dornier, Jaguar, Helicopter, Avionics and any other military aviation industry as Electronic equipment and aircraft electrical wiring harness	

1.	Type Approval No.	:	890	
2.	Approval Title	:	Polytetrafluoroethylene/Polyimide tape insulated & sintered Electrical Wires & Cables Part No.RW81088-26 to 10AWG & Cables Part No.RC81088 – IJT to 4J\TJ-26 to 10 AWG	
3.	Validity of Approval	:	31 Dec 2013	
4.	Developer of the Item	:	M/s Radiant Cables Limited Hyderabad – 500 018	
5.	Governing Specification	:	a) MIL-W-81044 b) MIL-W-81044/12B c) MIL-C-27500G	
6.	Characteristics of Wire	:		
	a) Classification	:	Advanced Arc track resistant Normal / light weight	
	b) Voltage Rating	:	600 Vrms	
	c) Insulation Resistance	:	5000 MΩ	
	d) Conductor	:	Standard Tin coated copper	
	e) Insulation	:	Polytetrafluoroethylene /Polyimide Insulation	
	f) Temperature Range	:	-65 to +150° C	
7.	g) Life Cycle Test	:	500 hrs at 230°C	
8.	End Use of the Item	:	Electrical wires and cables for aircraft harness	

PART NUMBERING SYSTEM FOR WIRE

COLOUR CODE : 0 – BLACK, 2-RED, 4-YELLOW, 5-GREEN, 6-BLUE, 9- WHITE

SLASH SHEET NO. : 86 - SILVER COATED COPPER CONDUCTOR,
87 - NICKEL COATED COPPER CONDUCTOR,
88 - TIN COATED COPPER CONDUCTOR.

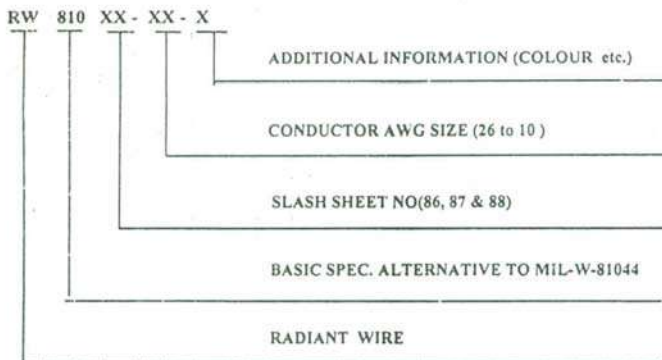

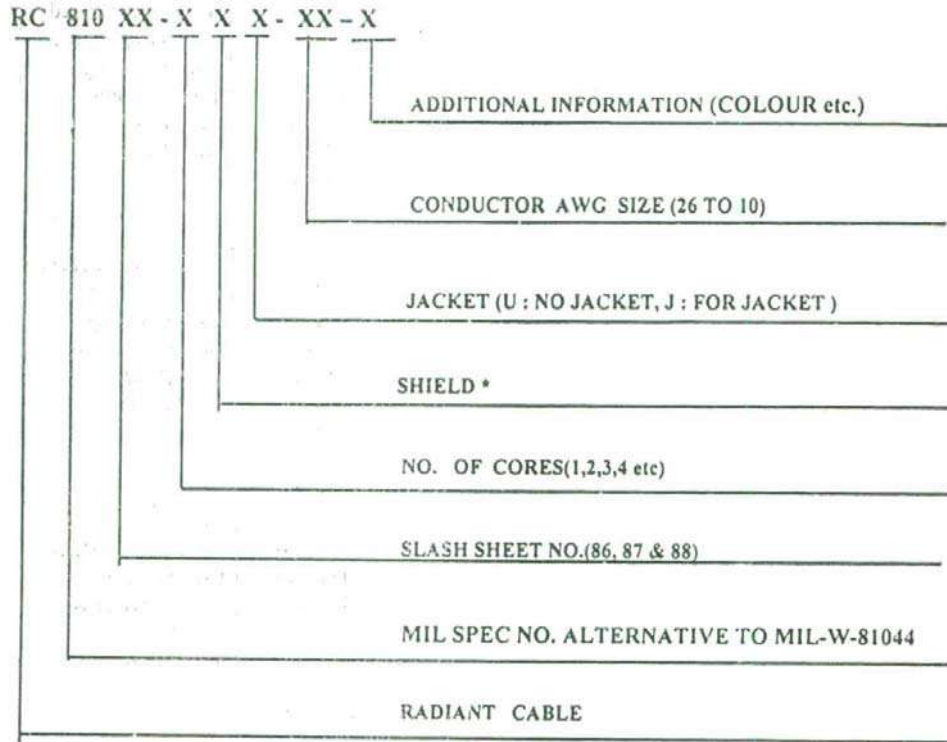

PART NUMBERING SYSTEM FOR CABLES



COLOUR CODE : 0 - BLACK, 2-RED, 4-YELLOW, 5-GREEN, 6-BLUE, 9- WHITE

- : U - NO SHIELD, T-TIN COATED COPPER BRAID, S: SILVER COATED COPPER BRAID
N : NICKEL COATED COPPER BRAID.

1.	Type Approval No.	:	891	
2.	Approval Title	:	Polytetrafluoroethylene/polyimide tape insulated & sintered Electrical Wires, Part No. RW 22780 to RW 22792A-26 to 4AWG & Cables Part No. RC 22780A to RC22792A-2UJ TO 04UJ/ITJ to 4TJ/ISJ TO 4SJ/INJ to 4NJ-26 TO 10AWG	
3.	Validity of Approval	:	31 Dec 2013	
4.	Developer of the Item	:	M/s Radiant Cables Limited Hyderabad – 500 018	
5.	Governing Specification	:	c) MIL-DTL-22759/80A-92A d) MIL-C-27500G e) MIL-DTL-27500H	
6.	Characteristics of Wire			
	a) Classification	:	Advanced Arc track resistant	
	b) Voltage Rating	:	600 Vrms	
	c) Insulation Resistance	:	5000 MΩ	
	d) Conductor	:	Standard Tin / Silver / Nickel coated high strength / ultra high strength copper alloy	
	e) Insulation	:	Composite Tape (FP/ Polyimide/FP) and FP tape	
	f) Temperature Range	:	-65 to +150° C for Tin Coated Copper -65 to + 200°C for Silver Coated Copper / Copper alloy -65 to + 260°C for Nickel Coated Copper / Copper alloy	
	g) Life Cycle Test	:	500 hrs at 230°C	
7.	End Use of the Item	:	Airborne application inclusive of Naval Air platforms Like LCA, Dornier, Jaguar, Helicopter, Avionics and any other military aviation industry as Electronic equipment and aircraft electrical wiring harness	

1.	Type Approval No.	:	896
2.	Approval Title	:	PTFE Insulated Fibre Glass Braided and Lacquered Wires and Cables Part No. 177T, 178T, 1177T, 1178T, 140T, 250NT, 1140T & 1350NKT
3.	Validity of Approval	:	31 Dec 2003
4.	Developer of the Item	:	M/s. Sanghvi Aerospace Pvt, Ltd. Ahmadabad 382 405.
5.	Governing Specification	:	a) AIR 4524E, Issue 1980 b) BS G 177 Mar 1961 c) MIL-DTL-27500
6.	Characteristics of Wire		
	a) Classification	:	-
	b) Voltage Rating	:	600 Vrms
	c) Operating Frequency	:	1600 Hz
	d) Insulation Resistance	:	≥ 500 MΩ
	e) Conductor	:	Silver / Nickel Plated Copper
	f) Insulation	:	PTFE Insulation wrapped and sealed
	g) Temperature Range	:	-65 to +250° C for Nickel plated copper -65 to + 200°C for Silver plated copper -50 to + 140°C for Silver plated copper / copper alloy
7.	End Use of the Item	:	Used as electrical cable and wires for electrical harness
8.	Other Details	:	These cables are used as a substitute of NYVIN cable of BS G 177.

1. Type Approval No. : **897**
2. Approval Title : **Aircraft Cables 6 Types (BIN, BINE, PTL-200, 250, PTLE-200, 250)**
3. Validity of Approval : 31 Dec 2013
4. Developer of the Item : M/s Jai Bharat Industries, New Delhi- 110 020
5. Governing Specification : a) TU-16-505.620-74 (Cable BIN and BINE)
b) TU-16-505.280-71(Cable PTL and PTLE)
6. Characteristics of Wire
 - a) Classification : External Heat Resistant
 - b) Voltage Rating : 250 V
 - c) Operating Frequency : Upto 2000 Hz (Cable BIN and BINE)
Upto 5000 Hz(Cable PTL and PTLE)
 - d) Conductor : BIN-Copper Silver Plated /
PTL Tinned Copper
 - e) Insulation : Glass Fluoro Plastic
 - f) Temperature Range : -60 to +250° C (Cable BIN and BINE)
-60 to + 200°C (Cable PTL and PTLE)
7. End Use of the Item
 - Used in MiG 21 & MiG27 aircraft
 - This cable is meant for fixed installation and used for aircraft wiring in the fuselage. These cables are resistant to wear and tear and heat they are durable to oil and fuel.



Other Details

Part Nos of the Cables

Sl.No	i	ii	iii	iv	v	vi
Type :	BIN	BINE	PTL-200	PTLE-200	PTL-250	PTLE-250
Data Sheet No.	7133/A	7144/A	7089/A	7100/A	7111/A	7122/A
Specification No.	TU-16-505-620-74		TU-16-505-280-71/79			
Part No. :	7133-0035 to 7133-7000	7144-0035 to 7144-7000	7089-0035 to 7089-7000	7100-0035 to 7100-7000	7111-0035 to 7111-7000	7122-0035 to 7122-7000
Sizes :	0.35 mm ²					
	0.50 mm ²					
	0.75 mm ²					

1. Type Approval No. : **898**
2. Approval Title : **Aircraft Cables 4 Types (MGSHV, MGSHVE, MGSHV-1, MGSHVE-1)**
3. Validity of Approval : 30 Jun 2015
4. Developer of the Item : M/s Jai Bharat Industries, New Delhi- 110 020
5. Governing Specification : TU-15-505.437-73/82 (Russian)
6. Characteristics of Wire
- a) Classification : Internal Non Heat Resistant Flexible
- b) Voltage Rating : 250 V
- c) Operating Frequency : Up to 5000 Hz
- d) Conductor : Tinned Copper
- e) Insulation : Polychlorovinyl, Electrical Insulation Fibres
- f) Temperature Range : - 50°C to + 70°C
7. End Use of the Item : – For aircraft electrical harness in MiG series aircraft
– These cables have two layers of impregnate natural silk. These are used in internal control circuits.



Other Details:

Part Nos. of the cables

MGSHV, MGSHVE, MGSHV-1, MGSHVE -1- 04Type Cables

Sl. No.	I	II	III	IV
Specn. No.	TU-15-505-437-73/82	TU-16-505-437-73/82	TU-16-505-437-73/82	TU-16-505-437-73/82
Data Sheet No.	7045/A	7056/A	7067/A	7078/A
Sizes	0.35mm ² 0.50mm ² 0.75mm ² 1.0mm ² 1.5mm ²	0.35mm ² 0.50mm ² 0.75mm ² 1.0mm ² 1.5mm ²	0.35mm ² 0.50mm ² 0.75mm ² 1.0mm ² 1.5mm ²	0.35mm ² 0.50mm ² 0.75mm ² 1.0mm ² 1.5mm ²
Part No.	7045-0012 to 7045-0150	7056-0012 to 7056-3075	7067-0035 to 7067-0150	7078-0035 to 7078-3075

1. Type Approval No. : **899**
2. Approval Title : **Cables 4 Types (BPVL, BPVLE, BPVLM, BPVLM E)**
3. Validity of Approval : 30 Jun 2015
4. Developer of the Item : M/s Jai Bharat Industries, New Delhi- 110 020
5. Governing Specification : TU-16-505.911-76 (Russian)
6. Characteristics of Wire
 - a) Classification : External Non-Heat Resistant
 - b) Voltage Rating : 500V
 - c) Operating Frequency : Up to 2000 Hz
 - d) Insulation strength : Should Withstand 1500 V / 50Hz
 - e) Insulation Resistance : > 500 MΩ
 - f) Conductor : Copper Tinned
 - g) Insulation : Vinyl chloride
 - h) Temperature Range : -60°C to +70°C
7. End Use of the Item : Different grades of these wires are used in different Aircraft systems such as internal lighting, fuel and power systems. BPVLM cables are combustible but durable to oil petrol mixture.



Other Details:

Part Nos. of the Cables

Sl. No	i	ii	iii	iv
Type	BPVL	BPVLE	BPVLM	BPVLM E
Data Sheet No.	7001/A	7012/A	7023/A	7034/A
Specification No.	TU-16-505-911-76			
Part No.	7001-0035 to 7001-9500	7012-0035 to 7012-9500	7023-0035 to 7023-0250	7034-0035 to 7034-0250
Sizes :	0.35 mm ²			
	0.50 mm ²			
	0.75 mm ²			
	1.0 mm ²			
	1.5 mm ²			
	2.5 mm ²			

1. Type Approval No. : **918**
2. Approval Title : **Cables – Radio Frequency & Semirigid with PTFE Dielectric**
3. Validity of Approval : 30 Jun 2014
4. Developer of the Item : M/s. Flu-Tef Industries
Ahmadabad 382 445
5. Governing Specification : MIL-DTL-17H
6. End Use of the Item :
 - For use on Aircraft / Helicopter / Avionic Systems Application.
 - Used in Wiring of Apparatus of Aircraft Electrical Circuit.
 - This cable is useful in high temperature and high frequency applications.

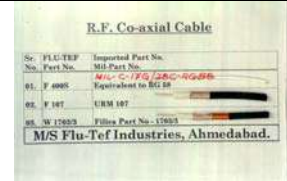

Other Details: **Part Nos. of the cables**

Sl..No.	Part No.	MIL Part No.	MIL data Sheet No./ Imported Data Sheet No.
1	F-188	M17/113-RG 316	MIL-C-17/113C
2	F-187	M17/94-RG 179	MIL-C-17/94F
3	F-196	M17/93-RG 178	MIL-C-17/93E
4	F-141	M17/111-RG 303	MIL-C-17/111C
5	F-142	M17/060-RG 142	MIL-C-17/060C
6	F-400	M17/128-RG 400	MIL-C-17/128B
7	F-144	M17/62-RG 144	MIL-C-17/62C
8	F-402	M17/130-RG 402	MIL-C-17/130E
9	F-393	M17/127-RG 393	MIL-C-17/127C
10	F-195	M17/195-RG 180	MIL-C-17/95E
11	W-1703/4	-----	Filica 1703/4 dt.2/80 HAL Spec A/DGM (DL)/ID/E 24/3/99. 2/11/99
12	W-1703/3	-----	Filica 1703/3 dt.2/80 HAL Spec A/DGM (DL)/ID/E 24/3/99. 2/11/99
13	F-400S	-----	As a substitute to RG 58
14	F107	UNIRADIO NO M107	BS 2316 Part 18 2 1968

TYPE NO: F188 (Ref. MIL PART NO: M17/113-RG316)

CONSTRUCTIONS DETAILS

	←1	1	Inner conductor	7 strands of silver plated copper covered steel. Strand dia:0.17mm,Overall Dia:0.51 ± 0.025mm
	←2	2	Dielectric core	Solid PTFE (Tape wrapped & sintered) Dia:1.52 ± 0.076mm
	←3	3	Outer conductor	Single braid of silver plated copper wire (strand dia 0.1mm) Coverage 95% nom.
	←4	4	Jacket	PTFE (Tape wrapped & sintered) Dia:2.49 ± 0.1mm

TECHNICAL CHARACTERISTICS

Continuous working voltage	: 900 Vrms max.				
Operating frequency	: 3 GHz max.				
Velocity of propagation	: 69.5 % nom.				
Operating temperature range	: -55° C to +200° C				
Conductor D.C. resistance (max at 20° C)	: 275.92 Ω/Km				
Conductor Elongation	: 10 % minimum				
Conductor Tensile strength	: 50 Klbs/in ² min.				
Weight	: 18 Kg/Km max.				
Voltage withstanding	: 2000 Vrms ± 10%				
Insulation resistance	: 23000 MΩ-Km				
Corona extinction voltage	: 1200 Vrms min.				
Characteristic Impedance	: 50 ± 2.0 ohms				
Frequency (GHz)	: 0.05	: 0.1	: 0.4	: 1.0	: 3.0
Attenuation(dB/100m max.)	: 24.6	: 36	: 68.8	: 108	: 190
Structural return loss(dB min.)	: 30	: 30	: 23	: 21	: 17
Power rating (Watts max.)	: 600	: 450	: 240	: 160	: 80

TEF TYPE NO: F187 (Ref. MIL PART NO: M17/94-RG179)

CONSTRUCTIONS DETAILS



←1	1	Inner conductor	7 strands of silver plated copper covered steel. Strand dia:0.1mm, Overall Dia:0.3 ± 0.025mm
←2	2	Dielectric core	Solid PTFE (Tape wrapped & sintered) Dia:1.6 ± 0.076mm
←3	3	Outer conductor	Single braid of silver plated copper wire (strand dia 0.1mm) Coverage 93% nom.
←4	4	Jacket	PTFE (Tape wrapped & sintered) Dia:2.54 ± 0.13mm

TECHNICAL CHARACTERISTICS

Continuous working voltage	: 900 Vrms max.
Operating frequency	: 3 GHz max.
Velocity of propagation	: 69.5 % nom.
Operating temperature range	: -55° C to +200° C
Conductor D.C. resistance (max at 20°C)	: 802.16 Ω/Km
Conductor Elongation	: 8 % minimum
Conductor Tensile strength	: 50 Klbs/in ² min.
Weight	: 16.07 Kg/Km max.
Voltage withstanding	: 2000 Vrms ± 10%
Insulation resistance	: 23000 MΩ-Km
Corona extinction voltage	: 1200 Vrms min.
Capacitance	: 75 Pf/m max.
Characteristic Impedance	: 73 ± 3.0 ohms
Frequency (GHz)	: 0.1 0.4 1.0 3.0
Attenuation (dB/100m max.)	: 32 69 82 141
Power rating (Watts max.)	: 570 310 200 110

TYPE NO: F196 (Ref. MIL PART NO: M17/093-RG178)

CONSTRUCTIONS DETAILS

	←1	1	Inner conductor	7 strands of silver plated copper covered steel. Strand dia:0.1mm,Overall Dia:0.30 ± 0.025mm
	←2	2	Dielectric core	Solid PTFE (Tape wrapped & sintered) Dia:0.84 ± 0.05mm
	←3	3	Outer conductor	Single braid of silver plated copper wire (strand dia 0.1mm) Coverage 96% nom.
	←4	4	Jacket	PTFE (Tape wrapped & sintered) Dia:1.8 ± 0.1mm

TECHNICAL CHARACTERISTICS

Continuous working voltage	: 750 Vrms max.				
Operating frequency	: 3 GHz max.				
Velocity of propagation	: 69.5 % nom.				
Operating temperature range	: -55° C to +200° C				
Conductor D.C. resistance (max at 20°C)	: 802.16 Ω/Km				
Conductor Elongation	: 10 % minimum				
Conductor Tensile strength	: 50 Klbs/in ² min.				
Weight	: 9.3 Kg/Km max.				
Voltage withstanding	: 2000 Vrms ± 10%				
Insulation resistance	: 23000 MΩ-Km				
Corona extinction voltage	: 1000 Vrms min.				
Capacitance	: 105 Pf/m max.				
Frequency (GHz)	: 0.05	: 0.1	: 0.4	: 1.0	: 3.0
Attenuation (dB/100m max.)	: 38	: 52.5	: 108	: 170	: 308
Structural return loss (dB min.)	: 26	: 25	: 22	: 19	: 14
Power rating (Watts max.)	: 380	: 250	: 123	: 78	: 41

TYPE NO: F141 (Ref. MIL PART NO: M17/111-RG303)

CONSTRUCTIONS DETAILS

	←1	1	Inner conductor	Solid silver plated copper covered steel. Overall Dia:0.94 ± 0.025mm
	←2	2	Dielectric core	Solid PTFE (Tape wrapped & sintered) Dia:2.95 ± 0.13mm
	←3	3	Outer conductor	Single braid of silver plated copper wire (strand dia 0.12mm) Coverage 95% nom.
	←4	4	Jacket	PTFE (Tape wrapped & sintered) Dia:4.32 ± 0.13mm

TECHNICAL CHARACTERISTICS

Continuous working voltage	: 1400 Vrms max.			
Operating frequency	: 3 GHz max.			
Velocity of propagation	: 69.5 % nom.			
Operating temperature range	: -55° C to +200° C			
Conductor D.C. resistance (max at 20°C)	: 58.92 Ω/Km			
Conductor Elongation	: 1 % minimum			
Conductor Tensile strength	: 110 Klbs/in ² min.			
Weight	: 46.13 Kg/Km max.			
Voltage withstanding	: 5000 Vrms ± 10%			
Insulation resistance	: 23000 MΩ-Km			
Corona extinction voltage	: 1900 Vrms min.			
Capacitance	: 105 pF/m max.			
Characteristic Impedance	: 50 ± 2 Ohms			
Frequency (GHz)	: 0.05	: 0.4	: 1.0	: 3.0
Attenuation (dB/100m max.)	: 8.9	: 28.2	: 49.2	: 92
Structural return loss (dB min.)	: 28	: 26	: 24	: 21.3
Power rating (Watts max.)	: 3400	: 1100	: 650	: 350

TYPE NO: F142 (Ref. MIL PART NO: M17/060-RG142)

CONSTRUCTIONS DETAILS

	←1	1	Inner conductor	Solid silver plated copper covered steel. Overall Dia:0.94 ± 0.025mm
	←2	2	Dielectric core	Solid PTFE (Tape wrapped & sintered) Dia:2.95 ± 0.13mm
	←3a	3	Outer conductor	Double braid of Silver Platted Copper Wire (strand dia 0.12mm) a) Inner Braid - Coverage 95% nom. b) Outer Braid – Coverage 93% nom.
	←3b			
	←4	4	Jacket	PTFE (Tape wrapped & sintered) Dia:4.95 ± 0.13mm

TECHNICAL CHARACTERISTICS

Continuous working voltage	: 1400 Vrms max.
Operating frequency	: 12.4 GHz max.
Velocity of propagation	: 69.5 % nom.
Operating temperature range	: -55° C to +200° C
Conductor D.C. resistance (max at 20°C)	: 63.97 Ω/Km
Conductor Elongation	: 1 % minimum
Conductor Tensile strength	: 110 Klbs/in ² min.
Weight	: 64 Kg/Km max.
Voltage withstanding	: 5000 Vrms + 10%
Insulation resistance	: 23000 MΩ-Km min.
Corona extinction voltage	: 1900 Vrms min.
Characteristics Impedance	: 50 ± 2 ohms
Capacitance	: 105 Pf/m max.
Frequency (GHz)	: 0.05 0.1 0.4 1.0 3.0 8.0
Attenuation (dB/100m max.)	: 13.12 18 38.38 62.3 115 216.5
Structural return loss (dB min.)	: 25.5 -- 23.8 22.0 17.0 17.0
Power rating (Watts max.)	: 3500 2400 1100 650 330 180

TYPE NO: F400 (Ref. MIL PART NO: M17/128-RG400)

CONSTRUCTIONS DETAILS

	←1	1	Inner conductor	19 strands of silver plated copper wire each strand 0.2mm , Overall Dia. : 0.98 ± 0.025mm
	←2	2	Dielectric core	Solid PTFE (Tape wrapped & sintered) Dia:2.95 ± 0.13mm
	←3a	3	Outer conductor	Double braid of Silver Platted Copper Wire (strand dia 0.12mm) a) Inner Braid - Coverage 95% nom. b) Outer Braid - Coverage 94% nom.
	←3b			
	←4	4	Jacket	PTFE (Tape wrapped & sintered) Dia:4.95 ± 0.13mm

TECHNICAL CHARACTERISTICS

Continuous working voltage	: 1400 Vrms max.
Operating frequency	: 12.4 GHz max.
Velocity of propagation	: 69.5 % nom.
Operating temperature range	: -55° C to +200° C
Conductor D.C. resistance (max at 20°C)	: 29.85 Ω/Km
Conductor Elongation	: 10 % minimum
Conductor Tensile strength	: not applicable
Weight	: 74.5 Kg/Km max.
Voltage withstanding	: 3000 Vrms + 10%
Insulation resistance	: 23000-MΩ-Km min.
Corona extinction voltage	: 1900 Vrms min.
Characteristics Impedance	: 50± 2 ohms
Capacitance	: 104.98 Pf/m max.
Frequency (GHz)	: 0.05 0.1 0.4 1.0 3.0 10 12.4
Attenuation (dB/100m max.)	: 10.5 14.8 34.4 55.7 125 256 295
Structural return loss (dB min.)	: 25.5 25.5 23.8 22 17 17 17
Power rating(Watts max.)	: 3500 2400 1100 650 350 140 --

TYPE NO: F144 (Ref. MIL PART NO: M17/062-RG144)

CONSTRUCTIONS DETAILS

	←1	1	Inner conductor	7 strands of silver plated copper covered steel. Stand Dia:0.44mm,Overall Dia:1.33±0.025mm
	←2	2	Dielectric core	Solid PTFE (Tape wrapped & sintered) Dia:7.24 ± 0.13mm
	←3	3	Outer conductor	Single braid of Silver Platted Copper Wire (strand dia 0.16mm), Coverage 94%
	←4a	4 a) b)	Barrier tapes	Barrier of unsintered PTFE Tapes (0.50 mm thickness)
	←4b			
	←5a	5 a) b)	Jacket	Double braid of Fibre Glass impregnated with Silicone Varnish. Dia:10.41 ± 0.25
←5b				

TECHNICAL CHARACTERISTICS

Continuous working voltage	: 3700 Vrms max.
Operating frequency	: 3 GHz max.
Velocity of propagation	: 69.5 % nom.
Operating temperature range	: -55° C to +200° C
Conductor D.C. resistance (max at 20°C)	: 45.6 Ω/Km
Conductor Elongation	: 1 % minimum
Conductor Tensile strength	: 110 Klbs/in ²
Weight	: 208.32 Kg/Km max.
Voltage withstanding	: 10000 Vrms + 10%
Insulation resistance	: 23000-MΩ-Km min.
Corona extinction voltage	: 5000 Vrms min.
Capacitance	: 72 Pf/m max.
Characteristic Impedance	: 75 ± 3 Ω
Frequency (GHz)	: 0.1 0.4 1.0 3.0
Attenuation (dB/100m max.)	: 5.2 14.8 23 59
Power rating (Watts max.)	: 6300 2800 1700 880

**TYPE NO:F402(Ref.MIL PART NO:M17/130-RG402 For Bare Copper)
F402T(Ref.MIL PART NO:M17/130-00001 For Tin Plated)**

CONSTRUCTIONS DETAILS

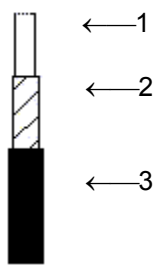
	←1	1	Inner conductor	Solids silver plated copper covered steel. Dia. : 0.92 ± 0.018mm
	←2	2	Dielectric core	Solid PTFE (Tape wrapped & sintered) Dia:2.97 ± 0.025mm
	←3	3	Outer conductor	For F402 Bare Copper Tube. For F402T Tin Plated Copper Tube. Diameter: 3.58 ± 0.025mm.

TECHNICAL CHARACTERISTICS

Continuous working voltage	: 1900 Vrms max.					
Operating frequency	: 20 GHz max.					
Velocity of propagation	: 69.5 % nom.					
Operating temperature range	: -40° C to +125° C					
Conductor D.C. resistance (max at 20°C)	: 67.58 Ω/Km					
Conductor Elongation	: 10 % minimum					
Conductor Tensile strength	: 40Klbs/in ²					
Weight	: F402 – 51.18 Kg/Km , F402T – 52.23 Kg/Km.					
Voltage withstanding	: 5000 Vrms ± 10%					
Corona extinction voltage	: 1900 Vrms min.					
Capacitance	: 98.10 Pf/m max.					
Characteristic Impedance	: 50 ± 1 Ω					
Frequency (GHz)	: 0.5	: 1.0	: 3.0	: 5.0	: 10	: 20
Attenuation(dB/100m max.)	: 26	: 39	: 69	: 95	: 148	: 230
Structural return loss (dB min.)	: 30	: 28.5	: 24.6	: 23	: 22.2	: 20.6
Power rating (Watts max.)	: 600	: 450	: 250	: 180	: 120	: 70

ENGINEERING NOTE: This cable is useful in Critical RF Performance Applications.

TYPE NO: F393 (Ref. MIL PART NO: M17/127-RG393)

CONSTRUCTIONS DETAILS

	←1	1	Inner conductor	7 strands of silver plated copper wire each strand 0.79mm , Overall Dia. : $2.39 \pm 0.025\text{mm}$
	←2	2	Dielectric core	Solid PTFE (Tape wrapped & sintered) Dia: $7.24 \pm 0.13\text{mm}$
	←3a	3	Outer conductor	Double braid of Silver Platted Copper Wire (strand dia 0.16mm) a) Inner Braid - Coverage 96% nom. b) Outer Braid – Coverage 98% nom.
	←3b			
	←4	4	Jacket	PTFE (Tape wrapped & sintered) Dia: $9.9 \pm 0.25\text{mm}$

TECHNICAL CHARACTERISTICS

Continuous working voltage	: 1875 Vrms max.
Operating frequency	: 11 GHz max.
Velocity of propagation	: 69.5 % nom.
Operating temperature range	: -55°C to $+200^{\circ}\text{C}$
Conductor D.C. resistance (max at 20°C)	: $4.98 \Omega/\text{Km}$
Conductor Elongation	: 20 % minimum
Conductor Tensile strength	: not applicable
Weight	: 260.40 Kg/Km max.
Voltage withstanding	: 7500 Vrms + 10%
Insulation resistance	: 23000-M Ω -Km min.
Corona extinction voltage	: 2500 Vrms min.
Characteristics Impedance	: 50 ± 2 ohms
Capacitance	: 104.98 Pf/m max.
Frequency (GHz)	: 0.05 0.1 0.4 3.0 11
Attenuation (dB/100m max.)	: 5.5 8.53 16.4 59 147.6
Structural return loss (dB min.)	: -- 25 24 20 16
Power rating (Watts max.)	: 9000 6300 2800 880 --

TYPE NO: F195 (Ref. MIL PART NO: M17/95-RG180)

CONSTRUCTIONS DETAILS

	←1	1	Inner conductor	7 strands of silver plated copper covered steel. Strand dia:0.1mm,Overall Dia:0.3 ± 0.025mm
	←2	2	Dielectric core	Solid PTFE (Tape wrapped & sintered) Dia:2.59 ± 0.076mm
	←3	3	Outer conductor	Single braid of silver plated copper wire (strand dia 0.1mm) Coverage 91% nom.
	←4	4	Jacket	PTFE (Tape wrapped & sintered) Dia:3.58 ± 0.1mm

TECHNICAL CHARACTERISTICS

Continuous working voltage	: 1100 Vrms max.
Operating frequency	: 3 GHz max.
Velocity of propagation	: 69.5 % nom.
Operating temperature range	: -55° C to +200° C
Conductor D.C. resistance (max at 20°C)	: 802.16 Ω/Km
Conductor Elongation	: 8 % minimum
Conductor Tensile strength	: 50 Klbs/in ² min.
Weight	: 29.46 Kg/Km max.
Voltage withstanding	: 2000 Vrms ± 10%
Insulation resistance	: 23000 MΩ-Km
Corona extinction voltage	: 1500 Vrms min.
Capacitance	: 57 Pf/m max.
Characteristic Impedance	: 95 ± 5.0 ohms
Frequency (GHz)	: 0.1 0.4 1.0 3.0
Attenuation(dB/100m max.)	: -- 55.8 -- --
Power rating (Watts max.)	: 800 400 250 135

TYPE NO: W 1703/3
Reference Datasheet : FILICA 1703/3, dt 2/1980

CONSTRUCTIONS DETAILS

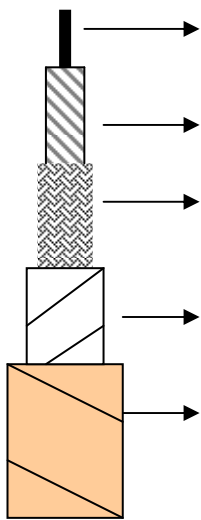

1	Inner conductor	7 strands of silver plated copper each Strand dia:0.81mm,Overall Dia:2.43±0.025mm
2	Dielectric core	Solid PTFE (Tape wrapped & sintered) Dia:7.00 ± 0.13mm
3	Inner Shield	Braid of silver plated copper wire (strand dia 0.16mm) Coverage 94% nom.
4	Inner Jacket	A layer of polyimide (Kapton) Tape Thickness : 0.06 mm
5	Outer Jacket	PTFE (Tape wrapped & sintered) Dia :8.40 ± 0.25mm Color : Brown .

TECHNICAL CHARACTERISTICS

Continuous working voltage	: 1875 Vrms max.				
Operating frequency	: 11 GHz max.				
Velocity of propagation	: 69.5 % nom.				
Operating temperature range	: -55° C to +200° C				
Conductor D.C. resistance (max at 20°C)	: 4.98 Ω/Km				
Conductor Elongation	: 20 % minimum				
Weight	: 168.00 Kg/Km max.				
Voltage withstanding	: 7500 Vrms ± 10%				
Insulation resistance	: 23000 MΩ-Km				
Corona extinction voltage	: 2500 Vrms min.				
Capacitance	: 105 pF/m max.				
Characteristic Impedance	: 50 ± 2.0 ohms				
Frequency (GHz)	: 0.05	: 0.1	: 0.4	: 3.0	: 11
Attenuation (dB/100m max.)	: 5.5	: 8.53	: 16.4	: 59.0	: 147.6
Structural return loss (dB min)	: -	: 25	: -	: 23	: 20

CONSTRUCTIONS DETAILS

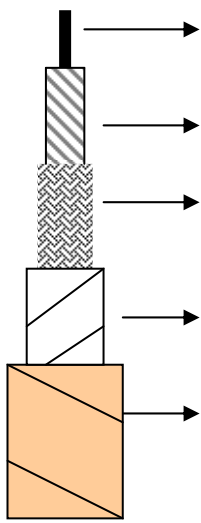

1	Inner conductor	7 strands of silver plated copper each Strand dia:0.33mm,Overall Dia:0.99±0.025mm
2	Dielectric core	Solid PTFE (Tape wrapped & sintered) Dia:2.95 ± 0.13mm
3	Inner Shield	Braid of silver plated copper wire (strand dia 0.13mm) Coverage 94% nom.
4	Inner Jacket	A layer of polyimide (Kapton) Tape Thickness : 0.06 mm
5	Outer Jacket	PTFE (Tape wrapped & sintered) Dia :3.95 ± 0.13mm Color : Brown .

TECHNICAL CHARACTERISTICS

Continuous working voltage	: 1400 Vrms max.					
Operating frequency	: 12.4 GHz max.					
Velocity of propagation	: 69.5 % nom.					
Operating temperature range	: -55° C to +200° C					
Conductor D.C. resistance (max at 20°C)	: 33.0 Ω/Km					
Conductor Elongation	: 15 % minimum					
Weight	: 36.5 Kg/Km max.					
Voltage withstanding	: 5000 Vrms ± 10%					
Insulation resistance	: 23000 MΩ-Km					
Corona extinction voltage	: 1900 Vrms min.					
Capacitance	: 105 pF/m max.					
Characteristic Impedance	: 50 ± 2.0 ohms					
Frequency (GHz)	: 0.05	: 0.1	: 0.4	: 1.0	: 3.0	: 10.0
Attenuation (dB/100m max.)	: 10.5	: 14.8	: 34.4	: 55.7	: 125	: 256
Structural return loss (dB min)	: 28	-	: 26	: 24	: 21.3	: 21.3

TYPE NO: F400S (EQUIVALENT TO: M17/028-RG058)

CONSTRUCTIONS DETAILS

	1	Inner conductor	19 strands of silver plated copper wire each strand 0.2mm , Overall Dia. : $0.96 \pm 0.025\text{mm}$
	2	Dielectric core	Solid PTFE (Tape wrapped & sintered) Dia: $2.95 \pm 0.13\text{mm}$
	3	Outer conductor	Single braid of silver plated copper wire (strand dia 0.12mm) Coverage 94% nom.
	4	Jacket	PTFE (Tape wrapped & sintered) Dia: $4.20 \pm 0.13\text{mm}$

TECHNICAL CHARACTERISTICS

Continuous working voltage	: 1400 Vrms max.
Operating frequency	: 3 GHz max.
Velocity of propagation	: 69.5 % nom.
Operating temperature range	: -55° C to +200° C
Conductor D.C. resistance (max at 20°C)	: 29.85 Ω/Km
Conductor Elongation	: 10 % minimum
Conductor Tensile strength	: not applicable
Weight	: 45 Kg/Km max.
Voltage withstanding	: 3000 Vrms ± 10%
Insulation resistance	: 23000 MΩ-Km
Corona extinction voltage	: 1900 Vrms min.
Capacitance	: 104.98 Pf/m max.
Characteristic Impedance	: 50 ± 2.0 Ohms
Frequency (GHz)	: 0.1 0.4 1.0 3.0
Attenuation (dB/100m max.)	: 14 34 66 134
Structural return loss (dB min.)	: -- 23.8 22 17
Power rating (Watts max.)	: 2400 1100 650 350

ENGINEERING NOTE: This cable is useful in high temperature and high frequency applications.

Note: This cable is one to one replacement RG 58. RG 58 is not recommended for use in aerospace applications as per MIL standard MIL-STD-454G since it uses PVC material.

TYPE NO: F107 (Ref. BS PART NO: URM 107)

CONSTRUCTIONS DETAILS

	←1	1	Inner conductor	7 Strands of silver plated copper wire. Strand Dia: 0.82, Overall Dia:2.46 ± 0.05mm
	←2	2	Dielectric core	Solid PTFE (Tape wrapped & sintered) Dia:7.25 ± 0.15mm
	←3	3	Outer conductor	Single braid of silver plated copper wire (strand dia 0.16mm) Coverage 94% nom.
	←4	4	Jacket	PTFE (Tape wrapped & sintered) Dia:9.00 ± 0.25mm

TECHNICAL CHARACTERISTICS

Continuous working voltage	: 5000 Vrms max.						
Operating frequency	: 11 GHz max.						
Velocity of propagation	: 69.5 % nom.						
Operating temperature range	: -55° C to +200° C						
Conductor D.C. resistance (max at 20°C)	: 4.73 Ω/Km						
Conductor Elongation	: 20 % minimum						
Conductor Tensile strength	: not applicable						
Weight	: 180 Kg/Km max.						
Voltage withstanding	: 10000 Vrms ± 10%						
Insulation resistance	: 23000 MΩ-Km min.						
Corona extinction voltage	: 4000 Vrms min.						
Capacitance	: 105 Pf/m max.						
Frequency (GHz)	: 0.05	: 0.1	: 0.2	: 0.3	: 0.6	: 1.0	: 3.0
Attenuation (dB/100m max.)	: 6	: 6.3	: 9.2	: 11.8	: 17.6	: 23.4	: 47.9
Structural return loss (dB min.)	: --	: 25				: 23	: 20
Power rating (Watts max.)		: 3350	: 2350	: 1900	: 1300	: 1000	: 545

1.	Type Approval No.	:	925																																																																												
2.	Approval Title	:	Fire Resistance wires & cables																																																																												
3.	Validity of Approval	:	30 Jun 2014																																																																												
4.	Developer of the Item	:	M/s. Sanghvi Aerospace Pvt. Ltd. Ahmadabad 382 405																																																																												
5.	Governing Specification	:	a) MIL-DTL-25038G for basic / core wire b) MIL-DTL-27500H for cables																																																																												
6.	Characteristics of Wire																																																																														
	a) Classification	:	Internal / External ; heat / fire resistant, flight critical wires (Resistant to Aero Fluids)																																																																												
	b) Voltage Rating	:	600V DC																																																																												
	c) Operating Frequency	:	Up to 2000 Hz																																																																												
	d) Conductor	:	Nickel Plated Copper																																																																												
	e) Insulation	:	High temp. insulation in the form fiber, tape and film																																																																												
	f) Temperature Range	:	50 ⁰ C to +260 ⁰ C (Rated), but capable to withstand 1090 ⁰ C flame applied for min. 15 minutes under 250V DC without loosing electrical integrity																																																																												
7.	End Use of the Item	:	Flight critical, fire resistant aircraft wiring, especially in engine zone and critical data recording systems in case of fire etc.																																																																												
8.	Other Details	:	Sanghvi Aerospace Part No. 25038(1/3)-**-▲ (for wires) & M27500A(1/3)-**-nC07 (for cables) is equivalent to M25038/ (1 or 3)-**-▲ and M27500A-**J(A/F)-nC07 where ** indicates size of conductor of wire and n indicates No. of core wires in cable																																																																												
				<table border="1"> <thead> <tr> <th>Sr. No.</th> <th>MIL Part No</th> <th>SAPL Part No</th> </tr> </thead> <tbody> <tr><td>1</td><td>M25038/1-22-*</td><td>250381-22</td></tr> <tr><td>2</td><td>M25038/1-20-*</td><td>250381-20</td></tr> <tr><td>3</td><td>M25038/1-18-*</td><td>250381-18</td></tr> <tr><td>4</td><td>M25038/1-16-*</td><td>250381-16</td></tr> <tr><td>5</td><td>M25038/1-14-*</td><td>250381-14</td></tr> <tr><td>6</td><td>M25038/1-12-*</td><td>250381-12</td></tr> <tr><td>7</td><td>M25038/1-10-*</td><td>250381-10</td></tr> <tr><td>8</td><td>M25038/1-8-*</td><td>250381-8</td></tr> <tr><td>9</td><td>M25038/1-6-*</td><td>250381-6</td></tr> <tr><td>10</td><td>M25038/1-4-*</td><td>250381-4</td></tr> <tr><td>11</td><td>M25038/1-2-*</td><td>250381-2</td></tr> <tr><td>12</td><td>M25038/1-1-*</td><td>250381-1</td></tr> <tr><td>13</td><td>M25038/1-0-*</td><td>250381-0</td></tr> <tr><td>14</td><td>M25038/1-00-*</td><td>250381-00</td></tr> <tr><td>15</td><td>M25038/1-000-*</td><td>250381-000</td></tr> <tr><td>16</td><td>M25038/1-0000-*</td><td>250381-0000</td></tr> <tr><td>17</td><td>M25038/3-22-*</td><td>250383-22</td></tr> <tr><td>18</td><td>M25038/3-22H-*</td><td>250383-22H</td></tr> <tr><td>19</td><td>M25038/3-20-*</td><td>250383-20</td></tr> <tr><td>20</td><td>M25038/3-18-*</td><td>250383-18</td></tr> <tr><td>21</td><td>M25038/3-16-*</td><td>250383-16</td></tr> <tr><td>22</td><td>M25038/3-14-*</td><td>250383-14</td></tr> <tr><td>23</td><td>M25038/3-12-*</td><td>250383-12</td></tr> <tr> <td colspan="3">1, 2 & 3 Core Shielded & Jacketed Cable also available</td> </tr> </tbody> </table>	Sr. No.	MIL Part No	SAPL Part No	1	M25038/1-22-*	250381-22	2	M25038/1-20-*	250381-20	3	M25038/1-18-*	250381-18	4	M25038/1-16-*	250381-16	5	M25038/1-14-*	250381-14	6	M25038/1-12-*	250381-12	7	M25038/1-10-*	250381-10	8	M25038/1-8-*	250381-8	9	M25038/1-6-*	250381-6	10	M25038/1-4-*	250381-4	11	M25038/1-2-*	250381-2	12	M25038/1-1-*	250381-1	13	M25038/1-0-*	250381-0	14	M25038/1-00-*	250381-00	15	M25038/1-000-*	250381-000	16	M25038/1-0000-*	250381-0000	17	M25038/3-22-*	250383-22	18	M25038/3-22H-*	250383-22H	19	M25038/3-20-*	250383-20	20	M25038/3-18-*	250383-18	21	M25038/3-16-*	250383-16	22	M25038/3-14-*	250383-14	23	M25038/3-12-*	250383-12	1, 2 & 3 Core Shielded & Jacketed Cable also available		
Sr. No.	MIL Part No	SAPL Part No																																																																													
1	M25038/1-22-*	250381-22																																																																													
2	M25038/1-20-*	250381-20																																																																													
3	M25038/1-18-*	250381-18																																																																													
4	M25038/1-16-*	250381-16																																																																													
5	M25038/1-14-*	250381-14																																																																													
6	M25038/1-12-*	250381-12																																																																													
7	M25038/1-10-*	250381-10																																																																													
8	M25038/1-8-*	250381-8																																																																													
9	M25038/1-6-*	250381-6																																																																													
10	M25038/1-4-*	250381-4																																																																													
11	M25038/1-2-*	250381-2																																																																													
12	M25038/1-1-*	250381-1																																																																													
13	M25038/1-0-*	250381-0																																																																													
14	M25038/1-00-*	250381-00																																																																													
15	M25038/1-000-*	250381-000																																																																													
16	M25038/1-0000-*	250381-0000																																																																													
17	M25038/3-22-*	250383-22																																																																													
18	M25038/3-22H-*	250383-22H																																																																													
19	M25038/3-20-*	250383-20																																																																													
20	M25038/3-18-*	250383-18																																																																													
21	M25038/3-16-*	250383-16																																																																													
22	M25038/3-14-*	250383-14																																																																													
23	M25038/3-12-*	250383-12																																																																													
1, 2 & 3 Core Shielded & Jacketed Cable also available																																																																															

1.	Type Approval No.	:	1015
2.	Approval Title	:	PTFE Electrical Wires and cables 177T, 178T, 1177T & 1178
3.	Validity of Approval	:	30 Jun 2014
4.	Developer of the Item	:	M/s. Flu-Tef Industries Ahmadabad 382 445
5.	Governing Specification	:	a) AIR 4524E for wires b) MIL-DTL-27500H for cables
6.	Characteristics of Wire		
	a) Classification	:	-
	b) Voltage Rating	:	600V rms
	c) Operating Frequency	:	Up to 1600Hz
	d) Conductor	:	177T,1177T Silver plated copper 178T,1178T Nickel plated copper
	e) Insulation	:	PTFE Insulation
	f) Temperature Range	:	177T : -65 ⁰ C to+200 ⁰ C, 178T,1178T: -65 ⁰ C to+250 ⁰ C
7.	End Use of the Item	:	Use on aircraft electrical system
8.	Other Details	:	177T & 178T – as a substitute for NYVIN type cables 1178T – As a substitute to UNINYVIN DYNIVIN and TRINYVIN Met Sheathed Cables



AIRCRAFT WIRES & CABLES

PTFE INSULATED FIBREGLASS BRAIDED & LACQUERED
(As a Substitute for NYVIN Type cables)

PRODUCT CARD

PRODUCT NO - 177T

CONSTRUCTION :

[1] Stranded conductor made up of Silver Plated Copper
 [2] PTFE insulation - wrapped & sealed.
 Nom. Thickness: AWG22to16-0.25mm,AWG 14&12-0.30,
 AWG10to06-0.38mm AWG4to1-0.50mm,AWG0&00 -0.63mm
 [3] Fibreglass braided and Lacquered
 Nom. Thickness: AWG22to14-0.13mm,AWG12to8-0.25mm,
 AWG6to00-0.38mm

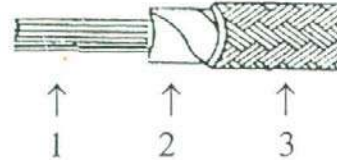

Voltage Rating : 600 V RMS
 Operating Temperature : -65⁰C to +200⁰C
 Operating Frequency : 1600 Hz

PART NUMBER	Cross Sectional Area	American Wire Gauge	MECHANICAL					ELECTRICAL		
			CONDUCTOR		CORE		Nominal Weight	D.C. Resistance at 20 ⁰ C (max.)	Current Rating	
			Construction	Dia meter		Over all Dia meter				
				Min	Max	Min.				Max.
sq.mm.	AWG	n x mm	(mm)	(mm)	mm.	mm.	g/m	Ohms / km	(A) AMPS	
177 T-22	0.38	22	12 X 0.2	0.76	0.83	1.40	1.60	6.50	50.9	7
177 T-20	0.60	20	19 X 0.2	0.94	1.04	1.60	1.80	9.31	32.2	11
177 T-18	0.93	18	19 X 0.25	1.21	1.32	1.87	2.10	13.80	20.6	16
177 T-16	1.34	16	19 X 0.30	1.40	1.54	1.91	2.4	16.81	14.3	22
177 T-14	1.91	14	27 X 0.30	1.77	1.90	2.53	2.81	26.34	10.1	32
177 T-12	3.18	12	45 X 0.30	2.28	2.44	3.28	3.60	38.98	6.0	41
177 T-10	4.65	10	37 X 0.40	2.67	2.92	3.81	4.22	64.43	3.51	55
177 T- 8	8.78	8	133 X 0.29	4.01	4.31	5.15	5.60	99.24	2.15	87
177 T- 6	13.53	6	133 X 0.36	5.02	5.51	6.46	7.11	159.21	1.37	115
177 T- 4	21.00	4	133 X 0.45	6.35	6.68	8.05	8.58	251.47	0.866	160
177 T- 2	32.00	2	189 X 0.45	8.00	8.30	9.70	10.20	357.00	0.627	200
177 T- 1	41.00	1	259 X 0.45	9.14	9.52	10.84	11.42	439.00	0.457	220
177 T- 0	53.00	0	1045X0.254	10.33	10.76	12.33	12.92	560.00	0.348	240
177 T- 00	67.40	00	1330X0.254	11.65	12.14	13.65	14.30	728.00	0.276	270

Note : 1) n = Numbers of Strands, 2) The Current shown are valid for single wire in Air.

CHARACTERISTICS :

These wires are suitable for installation on aerospace electrical systems.

Technical Requirements & Control Conditions
 AIR 4524 -E, 1980
 BSG - 177, March 1961.

AIRCRAFT WIRES & CABLES

PTFE INSULATED FIBREGLASS BRAIDED & LACQUERED
(As a Substitute for NYVIN Type cables)

PRODUCT CARD

PRODUCT NO - 178T

CONSTRUCTION :

- [1] Stranded conductor made up of Nickel Plated Copper
- [2] PTFE insulation - wrapped & sealed.
- Nom. Thickness: AWG22to16-0.25mm,AWG 14&12-0.30,
AWG10to06-0.38mm AWG4to1-0.50mm,AWG0&00 -0.63mm
- [3] Fibreglass braided and Lacquered
- Nom. Thickness: AWG22to14-0.13mm,AWG12to8-0.25mm,
AWG6to00-0.38mm

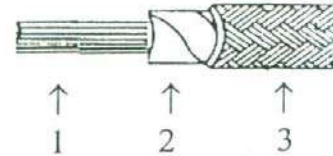

Voltage Rating : 600 V RMS
 Operating Temperature : -65⁰C to +250⁰C
 Operating Frequency : 1600 Hz

PART NUMBER	Cross Sectional Area	American Wire Gauge	MECHANICAL						ELECTRICAL				
			CONDUCTOR			CORE			Nominal Weight	D.C. Resistance at 20 ⁰ C (max.)	Current Rating		
			Construction	Dia meter		Over all Dia meter		g/m				Ohms / km	(A) AMPS
				Min (mm)	Max (mm)	Min. mm.	Max. mm.						
sq.mm.	AWG	n x mm											
178 T-22	0.38	22	12 X 0.2	0.76	0.83	1.40	1.60	6.50	54.5	7			
178 T-20	0.60	20	19 X 0.2	0.94	1.04	1.60	1.80	9.31	34.4	11			
178 T-18	0.93	18	19 X 0.25	1.21	1.32	1.87	2.10	13.80	22.0	16			
178 T-16	1.34	16	19 X 0.30	1.40	1.54	1.91	2.4	16.81	15.3	22			
178 T-14	1.91	14	27 X 0.30	1.77	1.90	2.53	2.81	26.34	10.8	32			
178 T-12	3.18	12	45 X 0.30	2.28	2.44	3.28	3.60	38.98	6.4	41			
178 T-10	4.65	10	37 X 0.40	2.67	2.92	3.81	4.22	64.43	4.06	55			
178 T- 8	8.78	8	133 X 0.29	4.01	4.31	5.15	5.60	99.24	2.27	87			
178 T- 6	13.53	6	133 X 0.36	5.02	5.51	6.46	7.11	159.21	1.43	115			
178 T- 4	21.00	4	133 X 0.45	6.35	6.68	8.05	8.58	251.47	0.90	160			
178 T- 2	32.00	2	189 X 0.45	8.00	8.30	9.70	10.20	357.00	0.627	200			
178 T- 1	41.00	1	259 X 0.45	9.14	9.52	10.84	11.42	439.00	0.466	220			
178 T- 0	53.00	0	1045X0.254	10.33	10.76	12.33	12.92	560.00	0.364	240			
178 T- 00	67.40	00	1330X0.254	11.65	12.14	13.65	14.30	728.00	0.285	270			

Note : 1) n = Numbers of Strands, 2) The Current shown are valid for single wire in Air.

CHARACTERISTICS :

These wires are suitable for installation on aerospace electrical systems.

Technical Requiements & Control Conditions

AIR 4524 -E, 1980
 BSG - 177, March 1961.

Aircraft Wires and Cables

PTFE Insulated ,Fibreglass braided, Screened and Fibreglass braided and Lacquered sheathed.
(As a Substitute to Uninyvin Dynyvin and Trinyvin Met Sheathed Cables)

PRODUCT CARD

PRODUCT NO : 1178 T

CONSTRUCTION :

1,2, or 3 Cores Type 178 T are covered with

- [1] A Nickel plated copper braided screen (coverage > 70%)
- [2] Thin PTFE Isolator (BARRIER TAPE)(0.15mm Thick Nom)
- [3] Fibreglass braid + Lacquered (0.25 Thick Nom)

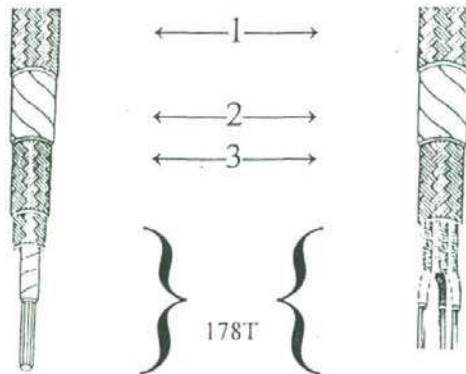

Voltage Rating : 600V RMS

Operating Temperature : -65⁰C to + 250⁰C

PART No	Cross Sectional Area (Sq.mm)	American Wire Gauge (AWG)	CORES 178T		SCREEN AND SHEATHED		
			Construction n X mm	OD of the Cores (mm) Min. Max.	Screen Strand Dia (mm)	Overall Dia (Max) (mm)	Average Weight g/m.
1178T-22-1S07	0.38	22	12 X 0.20	1.40 1.60	0.10	2.70	16.43
1178T-20-1S07	0.60	20	19 X 0.20	1.60 1.80	0.10	2.90	20.90
1178T-18-1S07	0.93	18	19 X 0.25	1.87 2.10	0.10	3.20	27.23
1178T-16-1S07	1.34	16	19 X 0.30	1.91 2.40	0.10	3.50	34.96
1178T-14-1S07	1.91	14	27 X 0.30	2.53 2.81	0.12	4.16	42.00
1178T-22-2S07	0.38	22	12 X 0.20	1.40 1.60	0.12	4.50	32.00
1178T-20-2S07	0.60	20	19 X 0.20	1.60 1.80	0.12	4.90	41.00
1178T-18-2S07	0.93	18	19 X 0.25	1.87 2.10	0.12	5.50	52.77
1178T-16-2S07	1.34	16	19 X 0.30	1.91 2.40	0.12	6.25	63.00
1178T-14-2S07	1.91	14	27 X 0.30	2.53 2.81	0.12	7.00	84.00
1178T-22-3S07	0.38	22	12 X 0.20	1.40 1.60	0.12	4.95	44.0
1178T-20-3S07	0.60	20	19 X 0.20	1.60 1.80	0.12	5.40	52.84
1178T-18-3S07	0.93	18	19 X 0.25	1.87 2.10	0.12	6.00	68.86
1178T-16-3S07	1.34	16	19 X 0.30	1.91 2.40	0.12	6.70	81.54
1178T-14-3S07	1.91	14	27 X 0.30	2.53 2.81	0.12	7.50	115.22

Note : 1) n = Numbers of Strands

Technical Requiriements & Control Conditions

- Basic core : AIR 4524 E , 1980 and BSG 177
- British spec of March 1961
- Finish cable : MIL-DTL-27500 H, 10 Dec, 1997)

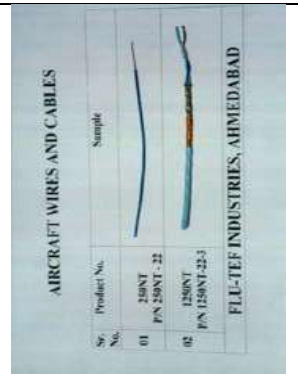

- 1. Type Approval No. : **1016**
- 2. Approval Title : **PTFE Electrical Wires and cables 250NT & 1250NKT**
- 3. Validity of Approval : 30 Jun 2014
- 4. Developer of the Item : M/s. Flu-Tef Industries
Ahmadabad 382 445
- 5. Governing Specification : a) AIR 4524 for wires
b) MIL-DTL-27500H for cables
- 6. Characteristics of Wire
 - a) Classification : -
 - b) Voltage Rating : 600V rms
 - c) Conductor : Nickel plated copper conductor
 - d) Insulation : PTFE Insulation
 - e) Temperature Range : -50⁰C to +250⁰C
- 7. End Use of the Item : Use on aircraft electrical system

AIRCRAFT WIRES & CABLES
PTFE INSULATED LIGHT WEIGHT FLEXIBLE TYPES

PRODUCT CARD

PRODUCT NO - 250 T

Voltage Rating : 600 V RMS
(Operating Temperature) : -50° C to +250° C
(ambient + rise) 280° C at peak

CONSTRUCTION :
[1] A Stranded conductor made up of Nickel Plated Copper or Nickel Plated Copper alloy (alloy providing a good mechanical behavior
[2] A PTFE insulation - wrapped / sealed.

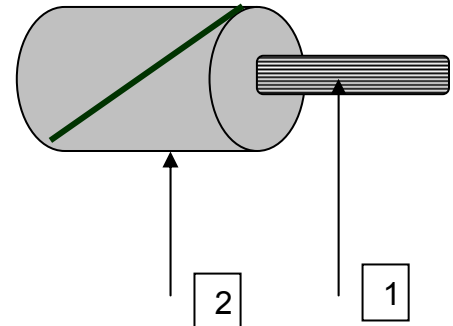

COLOUR CODING :

AWG	Colour
24-20-16-12	Light Blue
22-18-14-10	White

Other colours available on request

PART NUMBER	Cross Sectional Area sq. mm	American Wire Gauge AWG	MECHANICAL					ELECTRICAL	
			CONDUCTOR			CORE		D.C. Resistance at 20° C (maxi.) Ohms/km	Current Rating A
			Construction n x mm	Nominal Dia. +0.0mm -0.10mm mm.	Tensile Strength (mini.) N/mm ²	Overall Dia. +/-0.05 mm.	Average Weight g/m		
250NT - 24	0.21	24	19 X 0.12/NPC A LL	0.60	350	1.20	3.88	107.0	4
250NT - 22	0.38	22	12 X 0.20 / NPC	0.85	220	1.46	6.17	54.5	7
250NT - 20	0.60	20	19 X 0.20 / NPC	1.00	220	1.66	8.66	34.4	11
250NT - 18	0.93	18	19 X 0.25 / NPC	1.25	220	1.95	12.7	22.0	16
250NT - 16	1.34	16	19 X 0.30 / NPC	1.50	220	2.20	17.2	15.3	22
250NT - 14	1.91	14	27 X 0.30 / NPC	1.85	220	2.47	22.9	10.8	32
250NT - 12	3.18	12	45 X 0.30 / NPC	2.40	220	2.98	35.7	6.4	41
250NT - 10	4.65	10	37 X 0.40 / NPC	2.80	220	3.76	54.0	3.51	50

NPC = Nickel Plated Copper. NPC ALL = Nickel Plated Copper Alloy. n = Numbers of Strands

NOTE : - The currents shown are valid for single wire in Air.

CHARACTERISTICS :

Wiring of sub-assemblies at medium temperature up to 280° C at peak.

- * They are non-flammable
- * They withstand most solvents.

TECHNICAL REQUIREMENTS AND CONTROL CONDITIONS

Air 4524 E Specification of August 1980

PTFE INSULATED SCREENED -Polyimide + PTFE SHEATHED TYPES

PRODUCT CARD

PRODUCT NO - 1250NKT

Voltage Rating : 600 V RMS
 Operating Temperature : -50° C to + 250° C
 (ambient + risc) 280° C at peak.

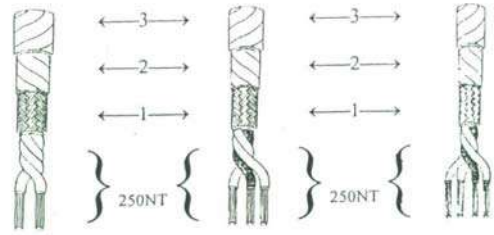

CONSTRUCTION :

- 1 to 6 Cores Type 250 NT covered with :
- [1] A Braided Screen made up of Nickel Plated Copper (70% Coverage).
 - [2] A Polyimide (Kapton) Sheath
 - [2] A wrapped and Sintered PTFE sheath.

PART NUMBER	Cross Sectional Area (sq.mm)	American Wire Gauge AWG	CORES 250N T		SCREEN AND SHEATH		
			Construction n x mm	O.D. of the core ± 0.05 mm	Screen strands Dia. mm	Overall Dia. (Max.) mm	Average weight g/m
1250NKT - 24 - 1	0.21	24	19 x 0.12 /NP ALL	1.20	0.10	2.6	9.83
1250NKT - 22 - 1	0.38	22	12 x 0.20 /NPC	1.46	0.10	2.9	13.1
1250NKT - 20 - 1	0.60	20	19 x 0.20 /NPC	1.66	0.10	3.1	16.4
1250NKT - 18 - 1	0.93	18	19 x 0.25 /NPC	1.95	0.12	3.5	23.0
1250NKT - 16 - 1	1.34	16	19 x 0.30 /NPC	2.47	0.12	3.8	28.6
1250NKT - 14 - 1	1.91	14	27 x 0.30 /NPC	2.98	0.12	4.1	35.5
1250NKT - 24 - 2	0.21	24	19 x 0.12 /NP ALL	1.20	0.12	3.8	18.3
1250NKT - 22 - 2	0.38	22	12 x 0.20 /NPC	1.46	0.12	4.3	24.9
1250NKT - 20 - 2	0.60	20	19 x 0.20 /NPC	1.66	0.12	4.7	31.5
1250NKT - 18 - 2	0.93	18	19 x 0.25 /NPC	1.95	0.12	5.4	41.8
1250NKT - 16 - 2	1.34	16	19 x 0.30 /NPC	2.47	0.12	6.0	53.7
1250NKT - 14 - 2	1.91	14	27 x 0.30 /NPC	2.98	0.12	6.6	67.3
1250NKT - 24 - 3	0.21	24	19 x 0.12 /NP ALL	1.20	0.12	4.0	24.2
1250NKT - 22 - 3	0.38	22	12 x 0.20 /NPC	1.46	0.12	4.5	33.5
1250NKT - 20 - 3	0.60	20	19 x 0.20 /NPC	1.66	0.12	5.0	42.2
1250NKT - 18 - 3	0.93	18	19 x 0.25 /NPC	1.95	0.12	5.7	58.7
1250NKT - 16 - 3	1.34	16	19 x 0.30 /NPC	2.47	0.12	6.4	74.7
1250NKT - 14 - 3	1.91	14	27 x 0.30 /NPC	2.98	0.12	7.0	94.7
1250NKT - 24 - 4	0.21	24	19 x 0.12 /NP ALL	1.20	0.12	4.19	30.8
1250NKT - 22 - 4	0.39	22	12 x 0.20 /NPC	1.46	0.12	4.90	43.6
1250NKT - 20 - 4	0.60	20	19 x 0.20 /NPC	1.66	0.12	5.43	56.0
1250NKT - 18 - 4	0.93	18	19 x 0.25 /NPC	1.95	0.12	6.21	78.6
1250NKT - 16 - 4	1.34	16	19 x 0.30 /NPC	2.47	0.12	7.62	105.6
1250NKT - 14 - 4	1.91	14	27 x 0.30 /NPC	2.98	0.12	8.99	135.3
1250NKT - 24 - 6	0.21	24	19 x 0.12 /NP ALL	1.20	0.12	4.55	46.2
1250NKT - 22 - 6	0.39	22	12 x 0.20 /NPC	1.46	0.12	5.33	67.6
1250NKT - 20 - 6	0.60	20	19 x 0.20 /NPC	1.66	0.12	5.93	95.3
1250NKT - 18 - 6	0.93	18	19 x 0.25 /NPC	1.95	0.12	6.80	135.2
1250NKT - 16 - 6	1.34	16	19 x 0.30 /NPC	2.47	0.12	8.36	182.0
1250NKT - 14 - 6	1.91	14	27 x 0.30 /NPC	2.98	0.12	9.89	217.4

NOTE : NPC = Nickel Plated Copper. NP ALL = Nickel Plated Alloy. n = Numbers of Strands

CHARACTRISTICS :

Same as 250NT T basic cores. Moreover, the PTFE overall sheath gives the following advantages :

- Very efficient protection of the screen against oxidation and corrosion
- Easy fitting of the cable.
- Safer handling.

TECHNICAL REQUIREMENTS

Basic core Air 4524 E Specification of August 1980.
 Finished Cable MIL-DTL-27500 H

Colour of Cores & Sheath

AWG	No of Cores	Core Colour	Sheath Colour
24-20-16	1	Light Blue	Light Blue
	2	Light Blue + Blue	Light Blue
	3	Light Blue + Blue + Yellow	Light Blue
	4	Light Blue + Blue + Yellow + Green	Light Blue
	6	Light Blue + Blue + Yellow + Green + Orange + Red	Light Blue
22-18-14	1	White	White
	2	White + Blue	White
	3	White + Blue + Yellow	White
	4	White + Blue + Yellow + Green	White
	6	White + Blue + Yellow + Green + Orange + Red	White

1. Type Approval No. : **1017**
2. Approval Title : **PTFE Electrical Wires and cables Product No.140T & 1140T**
3. Validity of Approval : 30 Jun 2014
4. Developer of the Item : M/s. Flu-Tef Industries
Ahmadabad 382 445
5. Governing Specification : a) AIR 4524E (Wires)
b) MIL-DTL-27500H (Cables)
6. Characteristics of Wire
 - a) Classification : -
 - b) Voltage Rating : 600 Vrms
 - c) Conductor : Silver plated copper conductor
 - d) Insulation : PTFE Insulation
 - e) Temperature Range : -50⁰C to +140⁰C
7. End Use of the Item : Use on aircraft electrical system



PTFE INSULATED LIGHT WEIGHT FLEXIBLE TYPES
PRODUCT CARD

PRODUCT NO - 140 T

Voltage Rating : 600 V RMS
 (Operating Temperature) : -50⁰ C to +140⁰ C
 (ambient + rise) 170⁰ C at peak

CONSTRUCTION :
 [1] A Stranded conductor made up of Silver Plated Copper or Silver Plated Copper alloy (alloy providing a good mechanical behaviour)
 [2] A PTFE insulation - wrapped / sealed.

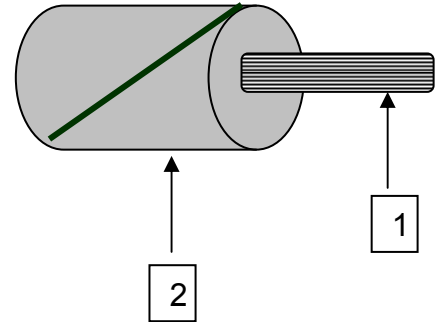

COLOUR CODING :

AWG	Colour
24-20-16-12	Light Blue
22-18-14-10	White

Other colors available on request.

PART NUMBER	Cross Sectional Area	American Wire Gauge	MECHANICAL					ELECTRICAL	
			CONDUCTOR			CORE		D.C. Resistance at 20 ⁰ C (maxi.)	Current Rating
			Construction	Nominal Dia. +0.0mm -0.10mm	Tensile Strength (mini.)	Overall Dia. +/-0.05	Average Weight		
sq. mm	AWG	n x mm	mm.	N/mm ²	mm.	g/m	Ohms/km	A	
140 T - 26	0.14	26	19 X 0.10/SP A LL	0.50	350	1.00	2.	144.0	3
140 T - 24	0.21	24	19 X 0.12/SP A LL	0.60	350	1.05	3.0	105.0	4
140 T - 22	0.38	22	12 X 0.20 / SPC	0.85	220	1.28	4.8	50.9	7
140 T - 20	0.60	20	19 X 0.20 / SPC	1.00	220	1.44	7.2	32.2	11
140 T - 18	0.93	18	19 X 0.25 / SPC	1.25	220	1.64	10.5	20.6	16
140 T - 16	1.34	16	19 X 0.30 / SPC	1.50	220	1.92	14.6	14.3	22
140 T - 14	1.91	14	27 X 0.30 / SPC	1.85	220	2.30	20.5	10.1	32
140 T - 12	3.18	12	45 X 0.30 / SPC	2.40	220	2.89	33.0	6.0	41
140 T - 10	4.65	10	37 X 0.40 / SPC	2.82	220	3.55	50.5	3.51	50

SPC = Silver Plated Copper. SP ALL = Silver Plated Copper Alloy. n = Numbers of Strands
 NOTE: - The currents shown are valid for single wire in Air.

CHARACTERISTICS :

Wiring of sub-assemblies at medium temperature
 Up to 170⁰ C at peak.

- * They are non-flammable
- * They withstand most solvents.

TECHNICAL REQUIREMENTS AND CONTROL CONDITIONS

Air 4524 E Specification of August 1980

PTFE INSULATED SCREENED - PTFE SHEATHED TYPES

PRODUCT CARD

PRODUCT NO - 1140 T

Voltage Rating : 600 V RMS
 Operating Temperature : -50° C to + 140° C
 (Ambient + risc) 170° C at peak.

CONSTRUCTION:

1 to 6 Cores Type 140 T covered with:

- [1] A Braided Screen made up of Silver Plated Copper (70% Coverage)
- [2] A wrapped and Sintered PTFE sheath

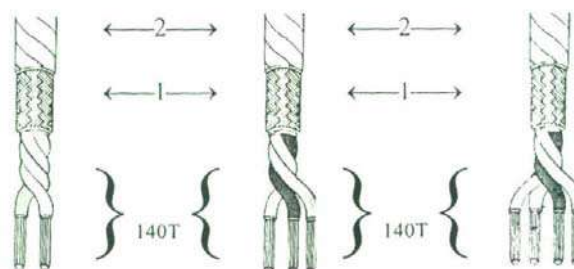

PART NUMBER	Cross Sectional Area (sq.mm)	American Wire Gauge AWG	CORES 140 T		SCREEN AND SHEATH		
			Construction n x mm	O.D. of the core ± 0.05 mm	Screen strands Dia. mm	Overall Dia. (Max.) mm	Average weight g/m
1140 T - 26 - 1	0.14	26	19 x 0.10/SP ALL	1.00	0.07	1.76	8.2
1140 T - 24 - 1	0.21	24	19 x 0.12 /SP ALL	1.10	0.07	2.0	9.0
1140 T - 22 - 1	0.38	22	12 x 0.20 /SPC	1.33	0.10	2.3	11.0
1140 T - 20 - 1	0.60	20	19 x 0.20 /SPC	1.49	0.10	2.5	14.0
1140 T - 18 - 1	0.93	18	19 x 0.25 /SPC	1.69	0.10	2.7	18.1
1140 T - 16 - 1	1.34	16	19 x 0.30 /SPC	1.97	0.10	3.0	23.3
1140 T - 14 - 1	1.91	14	27 x 0.30 /SPC	2.35	0.10	3.3	30.5
1140T - 12- 1	3.18	12	45 x 0.30 /SPC	2.94	0.12	3.9	57.7
1140 T - 26 - 2	0.14	26	19 x 0.10/SP ALL	1.00	0.10	2.9	13.5
1140 T - 24 - 2	0.21	24	19 x 0.12 /SP ALL	1.10	0.10	3.3	15.5
1140 T - 22 - 2	0.38	22	12 x 0.20 /SPC	1.33	0.10	3.8	21.8
1140 T - 20 - 2	0.60	20	19 x 0.20 /SPC	1.49	0.10	4.1	27.6
1140 T - 18 - 2	0.93	18	19 x 0.25 /SPC	1.69	0.12	4.5	38.7
1140 T - 16 - 2	1.34	16	19 x 0.30 /SPC	1.97	0.12	5.2	50.0
1140 T - 14 - 2	1.91	14	27 x 0.30 /SPC	2.35	0.12	5.9	65.3
1140T - 12- 2	3.18	12	45 x 0.30 /SPC	2.94	0.12	7.0	107.7
1140 T - 24 - 3	0.21	24	19 x 0.12 /SP ALL	1.10	0.10	3.5	19.3
1140 T - 22 - 3	0.38	22	12 x 0.20 /SPC	1.33	0.10	4.0	27.1
1140 T - 20 - 3	0.60	20	19 x 0.20 /SPC	1.49	0.12	4.4	38.4
1140 T - 18 - 3	0.93	18	19 x 0.25 /SPC	1.69	0.12	4.8	50.9
1140 T - 16 - 3	1.34	16	19 x 0.30 /SPC	1.97	0.12	5.5	66.3
1140 T - 14 - 3	1.91	14	27 x 0.30 /SPC	2.35	0.12	6.3	88.7
1140T - 12- 3	3.18	12	45 x 0.30 /SPC	2.94	0.12	7.3	141.5
1140 T - 24 - 4	0.21	24	19 x 0.12 /SP ALL	1.10	0.12	3.7	22.1
1140 T - 22 - 4	0.39	22	12 x 0.20 /SPC	1.33	0.12	4.4	34.6
1140 T - 20 - 4	0.60	20	19 x 0.20 /SPC	1.49	0.12	4.8	44.6
1140 T - 18 - 4	0.93	18	19 x 0.25 /SPC	1.69	0.12	5.3	60.0
1140 T - 16 - 4	1.34	16	19 x 0.30 /SPC	1.97	0.12	6.0	79.9
1140 T - 14 - 4	1.91	14	27 x 0.30 /SPC	2.35	0.12	6.9	108.0
1140T - 12- 4	3.18	12	45 x 0.30 /SPC	2.94	0.12	9.1	193.7
1140 T - 24 - 6	0.21	24	19 x 0.12 /SP ALL	1.10	0.12	4.1	33.20
1140 T - 22 - 6	0.39	22	12 x 0.20 /SPC	1.33	0.12	4.9	48.44
1140 T - 20 - 6	0.60	20	19 x 0.20 /SPC	1.49	0.12	5.4	64.40
1140 T - 18 - 6	0.93	18	19 x 0.25 /SPC	1.69	0.12	6.2	90.0
1140 T - 16 - 6	1.34	16	19 x 0.30 /SPC	1.97	0.12	7.1	120.0
1140 T - 14 - 6	1.91	14	27 x 0.30 /SPC	2.35	0.12	8.2	172.8
1140T - 12- 6	3.18	12	45 x 0.30 /SPC	2.94	0.12	10.0	274.6

NOTE: SPC = Silver Plated Copper. SP ALL = Silver Plated Alloy. n = Numbers of Strands

CHARACTRISTICS :

Same as 140 T basic cores. Moreover, the PTFE overall sheath gives the following advantages :

- Very efficient protection of the screen against oxidation and Corrosion.
- Easy fitting of the cable.
- Safer handling.

TECHNICAL REQUIREMENTS

Basic core Air 4524 E Specification of August 1980.
 Finished Cable MIL-DTL-27500 H

Colour of Cores & Sheath

AWG	No of Cores	Core Colour	Sheath Colour
24-20-16-12	1	Light Blue	Light Blue
	2	Light Blue + Blue	Light Blue
	3	Light Blue + Blue + Yellow	Light Blue
	4	Light Blue + Blue + Yellow + Green	Light Blue
	6	Light Blue + Blue + Yellow + Green + Orange + Red	Light Blue
26-22-18-14	1	White	White
	2	White + Blue	White
	3	White + Blue + Yellow	White
	4	White + Blue + Yellow + Green	White
	6	White + Blue + Yellow + Green + Orange + Red	White

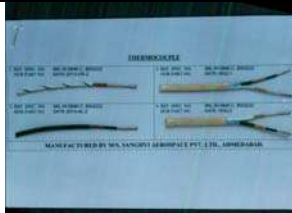
1.	Type Approval No.	:	1031	
2.	Approval Title	:	K Type Thermo Couple Extension wires & cables	
3.	Validity of Approval	:	31 Dec 2013	
4.	Developer of the Item	:	M/s. Sanghvi Aerospace Pvt, Ltd. Ahmadabad 382 405.	
5.	Governing Specification	:	a) MIL-W-5846, BS-4937, PAN SP-0-9300 for wires b) MIL-DTL-27500H for cables	
6.	Characteristics of Wire			
	a) Classification	:	Resistant to Aviation chemicals / fluids, flame	
	b) Voltage Rating	:	600 Vrms	
	c) Thermo emf @ 260° C	:	10.56 mv ± 0.10 mv (± 2.5°C) for class 2 10.56 mv ± 0.06 mv (± 1.5°C) for class 1	
	d) Conductor	:	Chromel (Plus). Alumel (Negative)	
	e) Insulation	:	High temp. Abrasion resistance, PTFE Insulation	
	f) Temperature Range	:	- 75°C to + 260° C	
7.	Decoding of Part No. of Wire **	:	SA - Sanghvi Aerospace make TE - Thermocouple extension wire CR - Chromel (Cu + Ni Alloy), Conductor (+ve leg) AL - Alumel (Al + Ni Alloy), Conductor (-ve leg)	
8.	End Use of the Item	:	K Type thermocouple extension Wire in aircraft for measuring temperature from 0 to 1260° C depending on size of wire. It has application for the connection in gas turBIN/BIN-Ne engine exhaust gas temp. conductor of aircraft / helicopter	
9.	Other Details	:	Sanghvi Aerospace Part No. SATE 2013 CR-1, SATE 2013 CR-2, SATE 2013 AL-1, SATE 2013 AL-2, SATE 1632 CR-1, SATE 1632 CR-2, SATE 1632 AL-1, SATE 1632 AL-2, SATE 6420 CR004, SATE 6420 CR006, SATE 6420 AL004, SATE 6420 AL006 are equivalent to CRALEFGLOSS EL 2013, Ducrasil EL 1632, PAN 6420 YR004 & 006	

1.	Type Approval No.	:	1062
2.	Approval Title	:	Data Bus Cable PartNo.10614T (Substitute to RAYCHEM Data Bus Cable 10614)
3.	Validity of Approval	:	30 Jun 2014
4.	Developer of the Item	:	M/s. Flu-Tef Industries Ahmadabad - 382 445
5.	Governing Specification	:	a) Product data sheet W10614T b) MIL-C-17G c) MIL-DTL-27500H, d) JSS51034
6.	Characteristics of Wire		
	a) Classification	:	Data Bus Cable
	b) Voltage Rating	:	600 Vrms
	c) Conductor	:	Stranded Silver Plated High Strength Copper Alloy
	d) Insulation	:	PTFE wrapped and sintered
	e) Temperature Range	:	-55°C to +200°C
7.	End Use of the Item	:	Used on aircraft electrical systems. Use on RAYCHEM data bus cable

<p>CONSTRUCTION:</p> <ol style="list-style-type: none"> 1. A standard conductor of Silver plated copper alloy (SPHA) 2. A dielectric layer of spiral wrapped & sintered PTFE Tape Color : White x Blue 3. PTFE filler 4. Wrap of Pre sintered PTFE Tape 5. Screen 1 Braid of Silver plated copper (SPC) 6. Screen 2 Wrap of High permeability tape(HPT) 7. Screen 3 Braid of Silver plated copper (SPC) 8. Jacket of PTFE Tape wrapped & sintered Color : White <p>➤ Temperature rating: -55°C to +200°C</p> <p>➤ Voltage rating : 600 Vrms</p>		<p>These Radio Frequency ,Twin axial known as Data bus cable for application in Electronic Equipment and Systems .The cable is primarily intended for interconnection of various equipment/sub systems used in Digital command/Response Time Division Multiplexing techniques on Aircraft. The requirements for Data bus cable specified herein comply with the requirements of US Military Standard</p> <p>MIL-STD-1553B: Digital Time Division Command/Response Multiplex Data Bus.</p> <p>Shielding effectiveness: The shield shall be selected with electromagnetic compatibility. Concerning the most commonly used types, the choice extends from single braids to complex shield configuration (braid, tape, braid) showing a very low transfer Impedance.</p>
--------------------------------------------------------------------------------------------------------------------------------------------------------------------------------------------------------------------------------------------------------------------------------------------------------------------------------------------------------------------------------------------------------------------------------------------------------------------------------------------------------------------------------------------------------------------------------------------------------------------------------------------------------------------	--	-------------------------------------------------------------------------------------------------------------------------------------------------------------------------------------------------------------------------------------------------------------------------------------------------------------------------------------------------------------------------------------------------------------------------------------------------------------------------------------------------------------------------------------------------------------------------------------------------------------------------------------------------------------------------------------------------------------------------------------------------------------------------------------

Physical Characteristics

Type no	Size AWG	Conductor Stranding n x mm	Core Diameter mm	Filler	Binder Tape	Screen			Jacket		Weight g/m
						1 mm	2	3 mm	Nature	Dia mm	
W10614T	24	19 x 0.12	1.08±0.05	PTFE	PTFE tape	0.10 SPC	HPT	0.10 SPC	PTFE	4.2	42

Electrical Characteristics

Type no	Impedance Ohms	Velocity of propagation %	Capacitance Mutual Pf/m maximum	Attenuation dB/100 m maximum	Surface transfer impedance milliohms/mtr maxi
W10614T	77 ± 5	69	70	4.0 at 1Mhz	0.2 at 30 Mhz

1.	Type Approval No.	:	1063	
2.	Approval Title	:	RF Coaxial Part No.FCOX-1000 and ADF Cable Part No.FCOX-1000-4	
3.	Validity of Approval	:	30 Jun 2014	
4.	Developer of the Item	:	M/s. Flu-Tef Industries Ahmadabad 382 445	
5.	Governing Specification	:	a) Product data sheet: FCOX -1000 b) Product data sheet: FCOX-1000-4 c) MIL-C-17G dated 09 Mar 1990	
6.	Characteristics of Wire			
	a) Classification	:	-	
	b) Voltage Rating	:	1000 Vrms	
	c) Operating Frequency	:	3 GHz (Max)	
	d) Characteristic Impedance	:	75Ω ± 3Ω	
	e) Conductor	:	Solid Silver Plated High Strength Copper Alloy	
	f) Insulation	:	PTFE Insulation wrapped and sintered	
	g) Temperature Range	:	-55°C to +200°C	
7.	End Use of the Item	:	Aircraft / Avionic Systems application. Used on RAYCHEM data bus cable	

1.	Type Approval No.	:	1064	
2.	Approval Title	:	PTFE Wires & cables 3 Core (As a substitute to Filotex type ETUDE19369)	
3.	Validity of Approval	:	30 Jun 2014	
4.	Developer of the Item	:	M/s. Flu-Tef Industries Ahmadabad 382 445	
5.	Governing Specification	:	a) Product data sheet F19369 b) AIR 4524E for Wires c) MIL-DTL-27500H for cables	
6.	Characteristics of Wire			
	a) Classification	:	Light weight flexible types	
	b) Voltage Rating	:	600 Vrms	
	c) Conductor	:	Nickel plated copper wire	
	d) Insulation	:	PTFE Insulation wrapped and sintered	
	e) Temperature Range	:	-65°C to +250°C	
7.	End Use of the Item	:	Use on JAGUAR AIRCRAFT for aircraft harness	

**PTFE Insulated Light Weight Flexible Types
(As A substitute to filotex Type ETUDE 19369)**

PRODUCT CARD PRODUCT NO : F 19369

- Construction :**
- [1] Basic Cores type 250 NT
 - [1a] A Stranded conductor made up of Nickel plated Copper
 - [1b] PTFE Insulation wrapped and sintered
 - [2] An overall Jacket of
 - [2a] A Tape layer of Polyimide/Kapton®
 - [2b] A PTFE Tape wrapped and sintered White

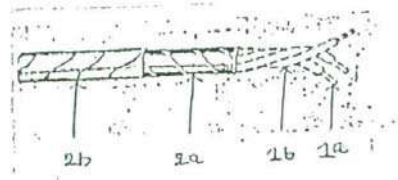

Voltage Rating : 600V RMS
Temperature Rating : -65°C to +250°C

PART No	Cross Sectional Area (Sq. mm)	American Wire Gauge AWG	MECHANICAL						No of Core	Sheath		
			Conductor			Nom Insulation thickness (mm)	Core			Nom. Thickness (mm)	Overall Dia-meter Max. (mm)	Avg. Weight g/m
			Construction n x mm	Dia meter			Min	Max				
F19369-20-3024	0.60	20	19X0.2MM	0.94	1.04	0.30	1.57	1.65	3	0.15	3.83	32.890

Note : 1) n = Numbers of Strands

Technical & Control Conditions : Basic Core : AIR 4524 E, 1980
Finished Cable : MIL-DTL-27500H

1.	Type Approval No.	:	1068																																													
2.	Approval Title	:	Polyimide Insulated wire and Cables Part No. SABIF/BIFE/BIFEZ (Corresponding to Russian type SABIF/BIFE / BIFE-N/BIFE / BIFE-NZ & SABIF-N/BIFE / BIFE-N-Z/BIFE / BIFE-NZ-N)																																													
3.	Validity of Approval	:	30 Jun 2014																																													
4.	Developer of the Item	:	M/s. Sanghvi Aerospace Pvt, Ltd. Ahmadabad 382 405.																																													
5.	Governing Specification	:	a) TU-16-505.645-76 (Russian) b) MIL-W-81381 / 7,8,9,10 & 11 & c) MIL-C-27500 H																																													
6.	Characteristics of Wire	:																																														
	a) Classification	:	External Heat Resistant (Excellent Cut through Resistant and Cold flow, Excellent Radiation Resistant, Good Outgassing Characteristics)																																													
	b) Voltage Rating	:	600V DC																																													
	c) Operating Frequency	:	Upto 2000Hz																																													
	d) Conductor	:	BIF : Silver plated Copper BIF-N: Nickel plated Copper																																													
	e) Insulation	:	PI Tape (Polyamide Fluoroplastic)																																													
	f) Temperature Range	:	-65 ⁰ C to +200 ⁰ C for BIF -65 ⁰ C to +260 ⁰ C for BIF-N																																													
7.	Decoding of Part No. of Wire **	:	<ul style="list-style-type: none"> - BIF – External wear resistant, Fluoro Plastic with Silver Plated Copper/ Alloy Conductor - BIFE / BIFE-N- Same as BIF, with shielding with Silver Plated Copper/ Alloy Conductor - BIFE / BIFE-NZ – same as BIFE / BIFE-N with protective jacket with Silver Plated Copper/ Alloy Conductor - BIF-N – External wear resistant, Fluoro Plastic with Nickle Plated Copper/ Alloy Conductor - BIFE / BIFE-N-N- Same as BIF-N, with shielding with Nickle Plated Copper/ Alloy Conductor - BIFE / BIFE-NZ-N – same as BIFE / BIFE-N-N with protective jacket with Nickle Plated Copper/ Alloy Conductor 																																													
8.	End Use of the Item	:	As aircraft armament, radar and airframe harness wires. These are heat and wear resistant cables.																																													
9.	Other Details	:	<table border="1"> <thead> <tr> <th>Sl. No.</th> <th>Russian Part No</th> <th>SAPL Part No</th> </tr> </thead> <tbody> <tr><td>1.</td><td>BIF- 0.20</td><td>SABIF- 0.20</td></tr> <tr><td>2.</td><td>BIF- 0.20 br</td><td>SABIF- 0.20 br</td></tr> <tr><td>3.</td><td>BIF - 0.35</td><td>SABIF - 0.35</td></tr> <tr><td>4.</td><td>BIF - 0.35 br</td><td>SABIF - 0.35 br</td></tr> <tr><td>5.</td><td>BIF - 0.50</td><td>SABIF - 0.50</td></tr> <tr><td>6.</td><td>BIF - 0.50 br</td><td>SABIF - 0.50 br</td></tr> <tr><td>7.</td><td>BIF - 0.75</td><td>SABIF - 0.75</td></tr> <tr><td>8.</td><td>BIF - 1.00</td><td>SABIF - 1.00</td></tr> <tr><td>9.</td><td>BIF - 1.50</td><td>SABIF - 1.50</td></tr> <tr><td>10.</td><td>BIF - 2.50</td><td>SABIF - 2.50</td></tr> <tr><td>11.</td><td>BIF - 4.00</td><td>SABIF - 4.00</td></tr> <tr><td>12.</td><td>BIF - 6.00</td><td>SABIF - 6.00</td></tr> <tr><td>13.</td><td>BIF - 10.00</td><td>SABIF - 10.00</td></tr> <tr> <td colspan="3">1, 2 & 3 Core Shielded or Shielded & Jacketed Cable also available</td> </tr> </tbody> </table>	Sl. No.	Russian Part No	SAPL Part No	1.	BIF- 0.20	SABIF- 0.20	2.	BIF- 0.20 br	SABIF- 0.20 br	3.	BIF - 0.35	SABIF - 0.35	4.	BIF - 0.35 br	SABIF - 0.35 br	5.	BIF - 0.50	SABIF - 0.50	6.	BIF - 0.50 br	SABIF - 0.50 br	7.	BIF - 0.75	SABIF - 0.75	8.	BIF - 1.00	SABIF - 1.00	9.	BIF - 1.50	SABIF - 1.50	10.	BIF - 2.50	SABIF - 2.50	11.	BIF - 4.00	SABIF - 4.00	12.	BIF - 6.00	SABIF - 6.00	13.	BIF - 10.00	SABIF - 10.00	1, 2 & 3 Core Shielded or Shielded & Jacketed Cable also available		
Sl. No.	Russian Part No	SAPL Part No																																														
1.	BIF- 0.20	SABIF- 0.20																																														
2.	BIF- 0.20 br	SABIF- 0.20 br																																														
3.	BIF - 0.35	SABIF - 0.35																																														
4.	BIF - 0.35 br	SABIF - 0.35 br																																														
5.	BIF - 0.50	SABIF - 0.50																																														
6.	BIF - 0.50 br	SABIF - 0.50 br																																														
7.	BIF - 0.75	SABIF - 0.75																																														
8.	BIF - 1.00	SABIF - 1.00																																														
9.	BIF - 1.50	SABIF - 1.50																																														
10.	BIF - 2.50	SABIF - 2.50																																														
11.	BIF - 4.00	SABIF - 4.00																																														
12.	BIF - 6.00	SABIF - 6.00																																														
13.	BIF - 10.00	SABIF - 10.00																																														
1, 2 & 3 Core Shielded or Shielded & Jacketed Cable also available																																																

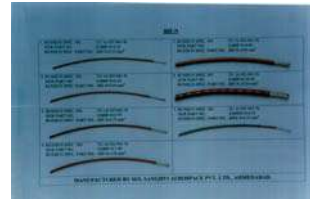

1.	Type Approval No.	:	1087	
2.	Approval Title	:	75 Ohm Tri axial Cable PT No. 7528 AT (TRIAX)	
3.	Validity of Approval	:	31 Dec 2014	
4.	Developer of the Item	:	M/s. Flu-Tef Industries Ahmadabad 382 445	
5.	Governing Specification	:	a) MIL-C-17-G b) Product Data sheet 7528AT (TRIAX)	
6.	Characteristics of Wire			
	a) Classification	:	External Heat Resistant	
	b) Voltage Rating	:	900V rms	
	c) Operating Frequency	:	3 GHz (Max)	
	d) Characteristic Impedance	:	75Ω± 3Ω	
	e) Velocity of propagation	:	69.5 % nom.	
	f) Conductor D.C. resistance (max at 20°C)	:	244.09 Ω/Km	
	Conductor Elongation	:	6 % minimum	
	Conductor Tensile strength	:	50 Klbs/in ² min.	
	Weight	:	32.0 Kg/Km max.	
	Voltage withstanding	:	5000 Vrms ± 10%	
	Insulation resistance	:	23000 MΩ-Km	
	Corona extinction voltage	:	1000 Vrms min.	
	Capacitance	:	75 pF/m max.	
	Attenuation			
	Frequency (GHz)	:	0.1 0.2 0.4	
	(dB/100m max.)	:	22 39 69	
	Power rating (Watts max.)	:	570 310 200 110	
	g) Conductor	:	Stranded silver plated high strength copper alloy	
	h) Insulation	:	PTFE Insulation	
	i) Temperature Range	:	-55°C to +200°C	
7.	End Use of the Item	:	Used for RF/Video signal transmitting in aircraft. (MiG 27 Upgrade project) This cable is useful in high temperature and high frequency applications	

CONSTRUCTIONS DETAILS OF TYPE NO: 7528AT Triax

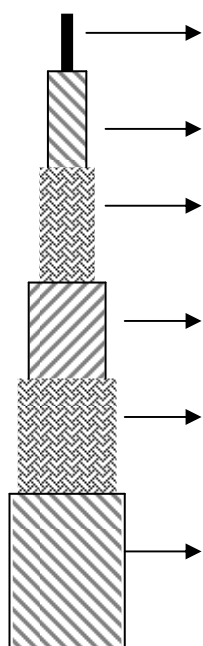

1	Inner conductor	7 strands of silver plated copper Alloy. Strand dia:0.127mm,Overall Dia:0.38±0.025mm
2	Dielectric core	Solid PTFE (Tape wrapped & sintered) Dia:1.97 ± 0.076mm
3	Inner Shield	Braid of silver plated copper wire (strand dia 0.1mm) Coverage 90% nom.
4	Inner Jacket	PTFE (Tape wrapped & sintered) Dia:2.67 ± 0.13mm
5	Outer Shield	Braid of silver plated copper wire (strand dia 0.1mm) Coverage 90% nom
6	Outer Jacket	PTFE (Tape wrapped & sintered) Dia :3. 6 ± 0.13mm

CABLE RADIO FREQUENCY, FLEXIBLE, TRIAXIAL, 75 OHMS, DRAWING	FLU-TEF INDUSTRIES TYPE 7530ALDT Triax,
<p>CONSTRUCTION DETAILS:</p> <p>1) Inner : AWG 30,7strands of silver plated Conductor : high strength copper Alloy Strand dia:0.1mm, Diameter:0.30±0.025mm</p> <p>2) Dielectric: ePTFE /PTFE Taped and Sintered core Diameter:1.22 ± 0.076mm</p> <p>3) Inner Shield : Braid of silver plated copper wire strand dia 0.08mm, Coverage 90% min.</p> <p>4) Inner Jacket : PTFE (Tape wrapped & sintered) Diameter:2.08 ± 0.1mm Color : Black.</p> <p>5)Outer Shield : Braid of silver plated copper wire strand dia: 0.08 mm, Coverage 90% min</p> <p>6)Outer Jacket : PTFE (Tape wrapped & Sintered) Diameter : 2.95 ±0.13 mm Color : Black.</p>	<p>TRIAxIAL CABLE</p>

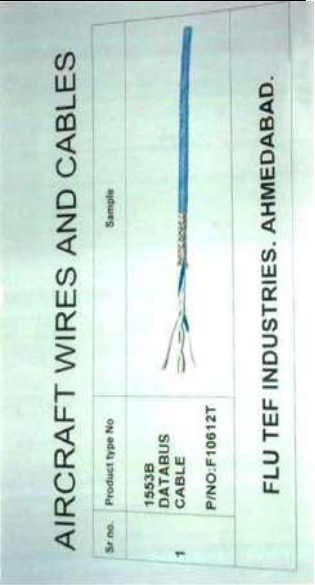
1.	Type Approval No.	:	1088	
2.	Approval Title	:	1553 B Data bus Cable Twinax single shield Pt No. F10612T	
3.	Validity of Approval	:	31 Dec 2014	
4.	Developer of the Item	:	M/s. Flu-Tef Industries Ahmadabad 382 445.	
5.	Governing Specification	:	a) RAYCHEM SPEC 1200, Issue 7 Rev E, 1982 b) MIL-C-17 & MIL-C-17/176D c) JSS 51034 (for basic core), d) MIL-DTL-27500H (finished cable) e) Product Data sheet F10612T	
6.	Characteristics of Wire			
	a) Classification	:	External Heat Resistant	
	b) Voltage Rating	:	750 Vrms (max)	
	c) Operating Frequency	:	Up to 10 MHz	
	d) Dielectric withstanding voltage	:	1500V for 1 minute	
	e) Rate	:	1 M bits / s	
	f) Impedance	:	75Ω ± 7 Ω	
	g) Conductor	:	Stranded silver plated high strength copper alloy	
	h) Insulation	:	PTFE Insulation	
	i) Temperature Range	:	-55°C to +200°C	
7.	End Use of the Item	:	<ul style="list-style-type: none"> – Used for avionics system in aircraft (MiG 27 Upgrade project.) – Useful in general high temperature application in accordance with MIL-STD-1553 – Aircrafts, Fighters & Helicopters. – Military :Weapon systems, Tanks, Missiles, Test benches – Space: Launch vehicles, Telecommunication, Space station 	

Twinax Databus cable in compliance with MIL-STD-1553B	TYPE NO : F10612T
CONSTRUCTION DETAILS: A. Conductor : Stranded silver plated high Strength copper alloy wire. B. Insulation : PTFE Taped and fused. C. Filler : 2 PTFE rod filler Twisting : 2 Core twisted together with 2 filler D. Shield : Round Braided shield of silver Plated high strength copper alloy wire . Coverage : 90 % minimum E. Jacket : PTFE taped & sintered. (Thickness : 0.25mm nom) Color : Light blue	

CORE					CABLE			
Conductor AWG	No of strands x Strand diameter r n x mm	Conductor diameter mm	Primary wire diameter mm	Filler diameter r nominal mm	No of core	Braid strand diameter mm	Diameter mm maximum	Weight g/m maximum
24/19/36	19x 0.12	0.58± 0.02	1.08± 0.05	0.80	2 white x blue	0.10	3.4	26.8

ELECTRICAL CHARACTERISTICS					
Characteristics Impedance Ohms	Capacitance pF / meter maximum	Nom Velocity of Propagation	Attenuation dB/100 meters maximum at 1 MHz	Insulation resistance MΩ-km minimum	Voltage withstanding bet ⁿ Core & shield Volts
77 ± 7	78	69 %	4.5	1524	1000

1. Type Approval No. : **1090**
2. Approval Title : **Electrical wires & Cables Type BPGRL of size 0.5, 0.75, 1.00, 1.50, 2.50 mm²**
3. Validity of Approval : 31 Dec 2014
4. Developer of the Item : M/s Uniflex Cables Ltd, Umbergaon, U.P – 396 171
5. Governing Specification : TU-16-505.124-78 (Russian)
6. Characteristics of Wire
 - a) Classification : External Heat Resistant
 - b) Voltage Rating : 250V
 - c) Operating Frequency : Up to 1000Hz
 - d) AC Voltage Test : 1500 V, 50 Hz for 1 minute
 - e) Conductor : Copper Silver plated
 - f) Insulation : Silicone Insulation (Rubber)
 - g) Temperature Range : -60°C to +125° C
7. End Use of the Item : Used in MiG Series aircraft for preparing movable looms

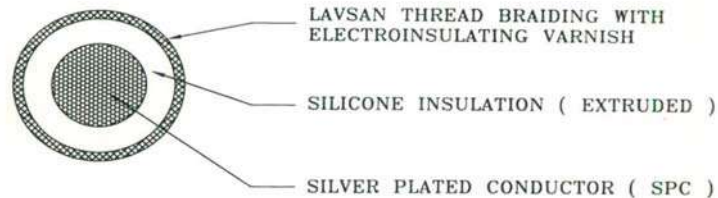
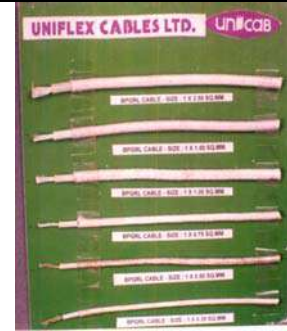

SR. NO.	CABLE SIZE	CONDUCTOR (NO. OF WIRES / WIRE DIA)	OVERALL DIA OF THE CABLE (NOMINAL)
01	0.35 Sq.mm.	49 / 0.10 mm	2.30 mm.
02	0.50 Sq.mm.	63 / 0.10 mm	2.60 mm.
03	0.75 Sq.mm.	98 / 0.10 mm	2.85 mm.
04	1.00 Sq.mm.	133 / 0.10 mm	3.40 mm.
05	1.50 Sq.mm.	190 / 0.10 mm	3.90 mm.
06	2.50 Sq.mm.	323 / 0.10 mm	4.40 mm.

1.	Type Approval No.	:	1117																																	
2.	Approval Title	:	Electrical wires & Cables SA-EQ-MGSHV & SA-EQ-MGSHVE (Equivalent to Russian wire MGSHV and MGSHVE respectively)																																	
3.	Validity of Approval	:	31 Dec 2014																																	
4.	Developer of the Item	:	M/s. Sanghvi Aerospace Pvt, Ltd. Ahmadabad 382 405.																																	
5.	Governing Specification	:	a) TU-16-505.437-73 (Russian) b) MIL-W-16878 for wire c) MIL-DTL-27500H for MGSHVE cable																																	
6.	Characteristics of Wire																																			
	a) Classification	:	Internal No Heat Resistant Flexible																																	
	b) Voltage Rating	:	380V AC for 500V DC up to 0.14 mm ² 1000V AC for 1500V DC from 0.20 mm ² to 1.5 mm ²																																	
	c) Operating Frequency	:	Up to 5000Hz																																	
	d) Conductor	:	Silver plated copper																																	
	e) Insulation	:	High Temperature Insulation (Polychlorovinyl, Electrical Insulation Fibres)																																	
	f) Temperature Range	:	-65°C to +200° C																																	
7.	Decoding of Part No. of Wire **		– MGSHV – Interior Flexible Silk braiding Vinylchloride – MGSHVE - Same as MGSHV, with shielding																																	
8.	End Use of the Item	:	Aircraft equipment / interconnect contact circuits. For aircraft harness																																	
9.	Other Details	:	<table border="1"> <thead> <tr> <th>Sr. No.</th> <th>Russian Part No</th> <th>SAPL Part No</th> </tr> </thead> <tbody> <tr> <td>1</td> <td>MGSHV – 0.12</td> <td>SA-EQ-MGSHV – 0.12 (TA - SCQ – 0012)</td> </tr> <tr> <td>2</td> <td>MGSHV – 0.14</td> <td>SA-EQ-MGSHV – 0.14 (TA - SCQ – 0014)</td> </tr> <tr> <td>3</td> <td>MGSHV – 0.20</td> <td>SA-EQ-MGSHV – 0.20 (TB - SCM – 0020)</td> </tr> <tr> <td>4</td> <td>MGSHV – 0.35</td> <td>SA-EQ-MGSHV – 0.35 (TB - SCM – 0035)</td> </tr> <tr> <td>5</td> <td>MGSHV – 0.50</td> <td>SA-EQ-MGSHV – 0.50 (TB - SCQ – 0050)</td> </tr> <tr> <td>6</td> <td>MGSHV – 0.75</td> <td>SA-EQ-MGSHV – 0.75 (TB - SCQ – 0075)</td> </tr> <tr> <td>7</td> <td>MGSHV – 1.00</td> <td>SA-EQ-MGSHV – 1.00 (TB - SCQ – 0100)</td> </tr> <tr> <td>8</td> <td>MGSHV – 1.50</td> <td>SA-EQ-MGSHV – 1.50 (TB - SCM – 0150)</td> </tr> <tr> <td colspan="3">Also 1 core Shielded cable available</td> </tr> <tr> <td colspan="3"> </td> </tr> </tbody> </table>	Sr. No.	Russian Part No	SAPL Part No	1	MGSHV – 0.12	SA-EQ-MGSHV – 0.12 (TA - SCQ – 0012)	2	MGSHV – 0.14	SA-EQ-MGSHV – 0.14 (TA - SCQ – 0014)	3	MGSHV – 0.20	SA-EQ-MGSHV – 0.20 (TB - SCM – 0020)	4	MGSHV – 0.35	SA-EQ-MGSHV – 0.35 (TB - SCM – 0035)	5	MGSHV – 0.50	SA-EQ-MGSHV – 0.50 (TB - SCQ – 0050)	6	MGSHV – 0.75	SA-EQ-MGSHV – 0.75 (TB - SCQ – 0075)	7	MGSHV – 1.00	SA-EQ-MGSHV – 1.00 (TB - SCQ – 0100)	8	MGSHV – 1.50	SA-EQ-MGSHV – 1.50 (TB - SCM – 0150)	Also 1 core Shielded cable available					
Sr. No.	Russian Part No	SAPL Part No																																		
1	MGSHV – 0.12	SA-EQ-MGSHV – 0.12 (TA - SCQ – 0012)																																		
2	MGSHV – 0.14	SA-EQ-MGSHV – 0.14 (TA - SCQ – 0014)																																		
3	MGSHV – 0.20	SA-EQ-MGSHV – 0.20 (TB - SCM – 0020)																																		
4	MGSHV – 0.35	SA-EQ-MGSHV – 0.35 (TB - SCM – 0035)																																		
5	MGSHV – 0.50	SA-EQ-MGSHV – 0.50 (TB - SCQ – 0050)																																		
6	MGSHV – 0.75	SA-EQ-MGSHV – 0.75 (TB - SCQ – 0075)																																		
7	MGSHV – 1.00	SA-EQ-MGSHV – 1.00 (TB - SCQ – 0100)																																		
8	MGSHV – 1.50	SA-EQ-MGSHV – 1.50 (TB - SCM – 0150)																																		
Also 1 core Shielded cable available																																				

1.	Type Approval No.	:	1119																																	
2.	Approval Title	:	Electrical wires & Cables Type SA-EQ-MGTFL & SA-EQ-MGTFL (Equivalent to Russian wire MGTFL and MGTFL respectively)																																	
3.	Validity of Approval	:	30 Jun 2016																																	
4.	Developer of the Item	:	M/s. Sanghvi Aerospace Pvt, Ltd. Ahmadabad 382 405.																																	
5.	Governing Specification	:	a) TU-OMTs-505.029-58 (Russian) b) MIL-W-16878 for wire c) MIL-DTL-27500H for MGTFL cable																																	
6.	Characteristics of Wire																																			
	a) Classification	:	Internal Heat Resistant Wire, resistant to Aircraft fluids																																	
	b) Voltage Rating	:	600VDC																																	
	c) Operating Frequency	:	Up to 2000Hz																																	
	d) Conductor	:	Silver plated copper																																	
	e) Insulation	:	High Temperature Insulation (Fluoroplastic Insulation)																																	
	f) Temperature Range	:	-65°C to +200° C																																	
7.	Decoding of Part No. of Wire **		– MGTFL – Interior Flexible heat resistant fluoroplastic insulated and varnished – MGTFL - Same as MGTFL, with shielding																																	
8.	End Use of the Item	:	General purpose aircraft wiring durable to aero fluids																																	
9.	Other Details	:	<table border="1"> <thead> <tr> <th>Sr. No.</th> <th>Russian Part No</th> <th>SAPL Part No</th> </tr> </thead> <tbody> <tr> <td>1</td> <td>MGTFL – 0.10</td> <td>SA-EQ-MGTFL – 0.10 (HB - SCQ – 0010)</td> </tr> <tr> <td>2</td> <td>MGTFL – 0.14</td> <td>SA-EQ-MGTFL – 0.14 (HB - SCQ – 0014)</td> </tr> <tr> <td>3</td> <td>MGTFL – 0.20</td> <td>SA-EQ-MGTFL – 0.20 (HB - SCQ – 0020)</td> </tr> <tr> <td>4</td> <td>MGTFL – 0.25</td> <td>SA-EQ-MGTFL – 0.25 (HB - SCQ – 0025)</td> </tr> <tr> <td>5</td> <td>MGTFL – 0.35</td> <td>SA-EQ-MGTFL – 0.35 (HB - SCM – 0035)</td> </tr> <tr> <td>6</td> <td>MGTFL – 0.50</td> <td>SA-EQ-MGTFL – 0.50 (HB - SCQ – 0050)</td> </tr> <tr> <td>7</td> <td>MGTFL – 0.75</td> <td>SA-EQ-MGTFL – 0.75 (HB – SCQ – 0075)</td> </tr> <tr> <td>8</td> <td>MGTFL – 1.00</td> <td>SA-EQ-MGTFL – 1.00 (HB – SCQ – 0100)</td> </tr> <tr> <td>9</td> <td>MGTFL – 1.50</td> <td>SA-EQ-MGTFL – 1.50 (HB – SCM – 0150)</td> </tr> <tr> <td colspan="3">Also 1 core Shielded cable available</td> </tr> </tbody> </table>	Sr. No.	Russian Part No	SAPL Part No	1	MGTFL – 0.10	SA-EQ-MGTFL – 0.10 (HB - SCQ – 0010)	2	MGTFL – 0.14	SA-EQ-MGTFL – 0.14 (HB - SCQ – 0014)	3	MGTFL – 0.20	SA-EQ-MGTFL – 0.20 (HB - SCQ – 0020)	4	MGTFL – 0.25	SA-EQ-MGTFL – 0.25 (HB - SCQ – 0025)	5	MGTFL – 0.35	SA-EQ-MGTFL – 0.35 (HB - SCM – 0035)	6	MGTFL – 0.50	SA-EQ-MGTFL – 0.50 (HB - SCQ – 0050)	7	MGTFL – 0.75	SA-EQ-MGTFL – 0.75 (HB – SCQ – 0075)	8	MGTFL – 1.00	SA-EQ-MGTFL – 1.00 (HB – SCQ – 0100)	9	MGTFL – 1.50	SA-EQ-MGTFL – 1.50 (HB – SCM – 0150)	Also 1 core Shielded cable available		
Sr. No.	Russian Part No	SAPL Part No																																		
1	MGTFL – 0.10	SA-EQ-MGTFL – 0.10 (HB - SCQ – 0010)																																		
2	MGTFL – 0.14	SA-EQ-MGTFL – 0.14 (HB - SCQ – 0014)																																		
3	MGTFL – 0.20	SA-EQ-MGTFL – 0.20 (HB - SCQ – 0020)																																		
4	MGTFL – 0.25	SA-EQ-MGTFL – 0.25 (HB - SCQ – 0025)																																		
5	MGTFL – 0.35	SA-EQ-MGTFL – 0.35 (HB - SCM – 0035)																																		
6	MGTFL – 0.50	SA-EQ-MGTFL – 0.50 (HB - SCQ – 0050)																																		
7	MGTFL – 0.75	SA-EQ-MGTFL – 0.75 (HB – SCQ – 0075)																																		
8	MGTFL – 1.00	SA-EQ-MGTFL – 1.00 (HB – SCQ – 0100)																																		
9	MGTFL – 1.50	SA-EQ-MGTFL – 1.50 (HB – SCM – 0150)																																		
Also 1 core Shielded cable available																																				

1.	Type Approval No.	:	1124	
2.	Approval Title	:	RF Coaxial 4 core electrical Cable (ADF Cable)	
3.	Validity of Approval	:	31 Dec 2014	
4.	Developer of the Item	:	M/s. Flu-Tef Industries Ahmadabad 382 445.	
5.	Governing Specification	:	a) MIL-C-17G b) Product Data Sheet FCOX 1000-4S	
6.	Characteristics of Wire			
	a) Classification	:	External Heat Resistant	
	b) Voltage Rating	:	1000 Vrms	
	c) Operating Frequency	:	3 GHz Max	
	d) Dielectric Strength	:	2000 V rms	
	e) Characteristic Impedance	:	75 Ω ± 3Ω	
	f) Velocity of Propagation	:	69.5 % nominal	
	g) Capacitance	:	73pf/Mtrs Max	
	h) Conductor	:	Stranded silver plated high strength copper alloy	
	i) Insulation	:	PTFE insulation	
	j) Temperature Range	:	-55°C to +200° C	
7.	End Use of the Item	:	Use on aircraft and avionics system application	

Cable, Flexible 4 Co axial Core with PTFE Dielectric for high temperature and high frequency Applications:

Technical & Control Condition : MIL-C-17G dt. 9 March, 1990

Construction:

Cable Consists of

1. Stranded Silver Plated High Strength Copper alloy (7/0.185mm)
2. A dielectric layer of wrapped & sintered PTFE Tape (Thickness:1.2mm Nom.)
3. Braid of Silver Plated copper wire such above 4 core twisted together.
4. Brier of unsintered PTFE Tape (Thick:0.15mm)
5. Sheath of Fibreglass braid & lacquered

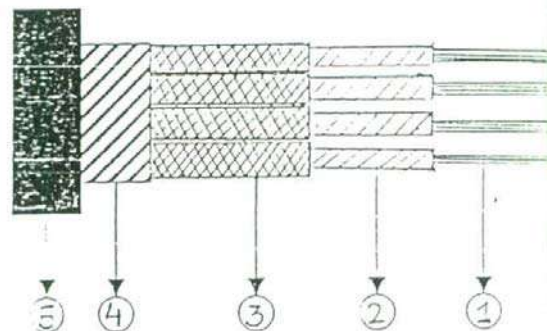

1. Type Approval No. : **1126**
2. Approval Title : **Electrical wires & Cables Type SA-EQ-BIN & SA-EQ-BINE**
(SA-EQ-BIN/BINE/BINEZ and SA-EQ-BIN-N/BINE-N/BINEZ-N equivalent to Russian wire BIN/BINE/BINEZ and BIN-N/BINE-Z/BINEZ-N respectively)
3. Validity of Approval : **31 Dec 2014**
4. Developer of the Item : M/s. Sanghvi Aerospace Pvt, Ltd.
Ahmadabad 382 405.
5. Governing Specification : a) TU-16-505.620-74 (Russian)
b) MIL-DTL-27500H
c) MIL-DTL-22759/86A
6. Characteristics of Wire
- a) Classification : External Heat Resistant (Arc Track Resistant, Resistant to Aero Fluids and Mould & Fungus resistant)
 - b) Voltage Rating : 600V DC
 - c) Operating Frequency : Up to 2000Hz
 - d) Insulation strength : 3000V AC, 50 Hz
 - e) Conductor : BIN/BIN-N : Silver plated Copper
BIN/BIN-N-N : Nickel plated Copper
 - f) Insulation : High Temperature Insulation (Glass Fluoro Plastic)
 - g) Temperature Range : -65°C to +200° C
7. Decoding of Part No. of Wire : BIN/BIN-N – External wear resistant, heat resistant
BIN/BIN-NE - Same as BIN/BIN-N, with shielding
BIN/BIN-NEZ – same as BIN/BIN-NE with protective jacket
BIN/BIN-N-N – External wear resistant, heat resistant
BIN/BIN-NE-N - Same as BIN/BIN-N-N, with shielding
BIN/BIN-NEZ-N – same as BIN/BIN-NE-N with protective jacket
8. End Use of the Item : As airframe wires in fuselage. They are durable to aerofluids
9. Other Details :

Sr. No.	Russian Part No	SAPL Part No
1	BIN/BIN-N-0.35	SABIN/SABIN-N – 0.35
2	BIN/BIN-N – 0.50	SABIN/SABIN-N – 0.50
3	BIN/BIN-N – 0.75	SABIN/SABIN-N – 0.75
4	BIN/BIN-N – 1.00	SABIN/SABIN-N – 1.00
5	BIN/BIN-N – 1.50	SABIN/SABIN-N – 1.50
6	BIN/BIN-N – 2.50	SABIN/SABIN-N – 2.50
7	BIN/BIN-N – 4.00	SABIN/SABIN-N – 4.00
8	BIN/BIN-N – 6.00	SABIN/SABIN-N – 6.00
9	BIN/BIN-N – 10.00	SABIN/SABIN-N – 10.00
10	BIN/BIN-N – 16.00	SABIN/SABIN-N – 16.00
11	BIN/BIN-N – 25.00	SABIN/SABIN-N – 25.00
12	BIN/BIN-N – 35.00	SABIN/SABIN-N – 35.00
13	BIN/BIN-N – 50.00	SABIN/SABIN-N – 50.00
14	BIN/BIN-N – 70.00	SABIN/SABIN-N – 70.00

Also Shielded 1,2 & 3 core and 1 Core shielded + Jacketted cable available.

1.	Type Approval No.	:	1180
2.	Approval Title	:	Twinax Electrical Wires& Cables120 Ohms Part No. 2524A2S06
3.	Validity of Approval	:	31 Dec 2015
4.	Developer of the Item	:	M/s. Flu-Tef Industries Ahmadabad 382 445.
5.	Governing Specification	:	a) Product data sheet : 2424A2S06 b) AIR 4524E for Basic Core c) MIL-DTL-27500H for cable d) BS 2316S for electrical
6.	Characteristics of Wire		
	a) Classification	:	Heat resistant winding wire
	b) Voltage Rating	:	1000V AC RMS
	c) Impedance	:	120 ±10 ohms
	d) Capacitance	:	40 pf /meter nominal
	e) Velocity ratio	:	69 %
	f) Conductor	:	Stranded silver plated high strength copper alloy
	g) Insulation	:	PTFE Taped and Sintered
	h) Temperature Range	:	-55 ⁰ C to +200 ⁰ C
7.	End Use of the Item	:	Used to carry mission computer signals to head up display unit in JAGUAR AIRCRAFT for DARIN II navigation system

TECHNICAL SPECIFICATION

Item Description :PTFE Insulated & Sheathed 120 OHMS Twinax Cable

Type No : 2524A2S06

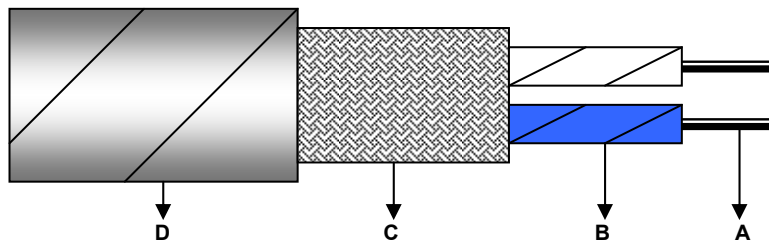

Construction Details

A Conductor	: Stranded silver plated high strength copper alloy
Size	: AWG 24/19/36
Strand diameter	: 0.127mm Nom
No of strands	: 19
Dia of conductor	: 0.64mm Nom
B Dielectric	: PTFE Taped and sintered
Core dimensions	: 2.05 +/- 0.1mm
No of core	: 2 (Twin Twisted)
Core colour	: White x Blue
C Shield	: Braid of silver plated copper wire, coverage > 90%
D Jacket	: PTFE Taped and sintered
Colour	: white
Finished cable dia	: 5.0 mm max.
Weight	: 36 g/m avg.

1.	Type Approval No.	:	1181	
2.	Approval Title	:	PTFE Electrical wires and cables Type SA-EQ-22759/6	
3.	Validity of Approval	:	31 Dec 2015	
4.	Developer of the Item	:	M/s. Sanghvi Aerospace Pvt, Ltd. Ahmadabad 382 405.	
5.	Governing Specification	:	a) MIL-W-22759/6B for Wire b) MIL-DTL-22759/87A for Cable	
6.	Characteristics of Wire			
	a) Classification	:	Wear resistant wire, resistant to aero fluids and arc tracking resistant	
	b) Voltage Rating	:	600V DC	
	c) Operating Frequency	:	Up to 2000 Hz	
	d) Conductor	:	Nickel plated Copper conductor	
	e) Insulation		High temp. and wear resistant insulation (FP/Polyimide/FP tape)	
	f) Temperature Range		-60 ^o C to +250 ^o C	
7.	End Use of the Item	:	Used in wiring of apparatus of aircraft electrical circuit.	
8.	Other Details	:	Sanghvi Aerospace Part No. SA-EQ-M22759/6-** is equivalent to MIL22759/6-**	

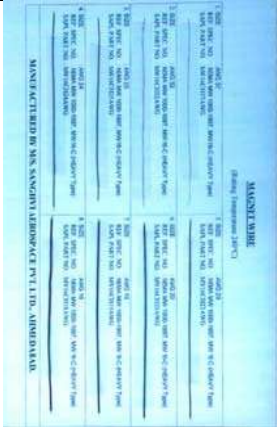
1.	Type Approval No.	:	1182	
2.	Approval Title	:	Heavy film insulated, aromatic polyimide Lacquered round copper wire (magnet wire)	
3.	Validity of Approval	:	31 Dec 2015	
4.	Developer of the Item	:	M/s. Sanghvi Aerospace Pvt, Ltd. Ahmadabad 382 405.	
5.	Governing Specification	:	a) NEMA MW 1000/ 16C (Heavy) b) MW 1000-1997, Rev 2 (other equivalent JW 1177/15B, IEC 6031717, IS 13730-7, BS 4663)	
6.	Characteristics of Wire	:		
	a) Classification	:	Heat resistant winding wire	
	b) Voltage Rating	:	600 V	
	c) Dielectric strength	:	≥ 7600V	
	d) Conductor	:	Copper Conductor	
	e) Insulation	:	Aromatic Polyimide resin	
	f) Temperature Range	:	-65 ⁰ C to +240 ⁰ C	
7.	End Use of the Item	:	Used in motors / generators / transformers / coils and other high temp operating apparatus as winding wires for continuous use up to 240" C. Used in sealed relays, hermetic refrigeration system, liquid filled transformers etc.	
8.	Other Details	:	Sanghvi Aerospace Part No. MW16C@**(S/A)WG @ indicates type of coating S for Single type H for Heavy type T for Triple type and Q for Quadruplicate ** indicates size of conductor are equivalent to NEMA part No. MW016C*χ*****Unc @ indicates type of coating S for Single type H for Heavy type T for Triple type and Q for Quadruplicate ***** indicates size of conductor	

AWG Size	NEMA Part No.	SAPL Part No.
4	MW016C*x00004Unc	MW16C*4AWG
5	MW016C*x00005Unc	MW16C*5AWG
6	MW016C*x00006Unc	MW16C*6AWG
7	MW016C*x00007Unc	MW16C*7AWG
8	MW016C*x00008Unc	MW16C*8AWG
9	MW016C*x00009Unc	MW16C*9AWG
10	MW016C*x00010Unc	MW16C*10AWG
11	MW016C*x00011Unc	MW16C*11AWG
12	MW016C*x00012Unc	MW16C*12AWG
13	MW016C*x00013Unc	MW16C*13AWG
14	MW016C*x00014Unc	MW16C*14AWG
15	MW016C*x00015Unc	MW16C*15AWG
16	MW016C*x00016Unc	MW16C*16AWG
17	MW016C*x00017Unc	MW16C*17AWG
18	MW016C*x00018Unc	MW16C*18AWG
19	MW016C*x00019Unc	MW16C*19AWG
20	MW016C*x00020Unc	MW16C*20AWG
21	MW016C*x00021Unc	MW16C*21AWG
22	MW016C*x00022Unc	MW16C*22AWG
23	MW016C*x00023Unc	MW16C*23AWG
24	MW016C*x00024Unc	MW16C*24AWG
25	MW016C*x00025Unc	MW16C*25AWG
26	MW016C*x00026Unc	MW16C*26AWG
27	MW016C*x00027Unc	MW16C*27AWG
28	MW016C*x00028Unc	MW16C*28AWG
29	MW016C*x00029Unc	MW16C*29AWG
30	MW016C*x00030Unc	MW16C*30AWG
31	MW016C*x00031Unc	MW16C*31AWG
32	MW016C*x00032Unc	MW16C*32AWG
33	MW016C*x00033Unc	MW16C*33AWG
34	MW016C*x00034Unc	MW16C*34AWG
35	MW016C*x00035Unc	MW16C*35AWG
36	MW016C*x00036Unc	MW16C*36AWG
37	MW016C*x00037Unc	MW16C*37AWG
38	MW016C*x00038Unc	MW16C*38AWG
39	MW016C*x00039Unc	MW16C*39AWG
40	MW016C*x00040Unc	MW16C*40AWG
41	MW016C*x00041Unc	MW16C*41AWG
42	MW016C*x00042Unc	MW16C*42AWG
43	MW016C*x00043Unc	MW16C*43AWG
44	MW016C*x00044Unc	MW16C*44AWG
<ul style="list-style-type: none"> Indicates type of coating denoted by S= Single, H= Heavy, T=Triple, Q=Quadruple 		

1. Type Approval No. : **1207**
2. Approval Title : **Polyimide/PTFE Insulated Electrical wires & Cables**
(Equivalent to Russian type BPVL/ BPVLE, BPVLM & BPVLM E)
3. Validity of Approval : **31 Dec 2015**
4. Developer of the Item : M/s. Sanghvi Aerospace Pvt, Ltd.
Ahmadabad 382 405.
5. Governing Specification : a) TU-16-505.911-76 (Russian)
b) MIL-DTL-22759/86A,
c) MIL-W-22759,
d) MIL-DTL-27500H
6. Characteristics of Wire
 - a) Classification : External Non Heat Resistant
 - b) Voltage Rating : 600V DC
 - c) Operating Frequency : 200 Hz
 - d) Conductor : Silver plated Copper Conductor
 - e) Insulation : High temperature insulation
 - f) Temperature Range : -65°C to +200°C
7. Decoding of Part No. of Wire : BPVL/BPVLM- Onboard cable with fluoropolymer plastic insulation with varnished cotton braid
BPVLE/BPVLM E- Same as BPVL / BPVLM with Shielding
8. End Use of the Item : As Hook-up wires in Armament, radio / electrical /experimental equipment, AC circuit of Russian aircraft/ helicopters
9. Other Details :

Sr. No.	Russian Part No	SAPL Part No
1	BPVL-0.35	SA-EQ-BPVL-0.35 (HB – SCP – 0035)
2	BPVL-0.50	SA-EQ-BPVL-0.50 (HB – SCP – 0050)
3	BPVL-0.75	SA-EQ-BPVL-0.75 (HB – SCP – 0075)
4	BPVL-0.88	SA-EQ-BPVL-0.88 (HB – SCM – 0088)
5	BPVL-1.00	SA-EQ-BPVL-1.00 (HB – SCM – 0100)
6	BPVL-1.25	SA-EQ-BPVL-1.25 (HB – SCM – 0125)
7	BPVL-1.50	SA-EQ-BPVL-1.50 (HB – SCM – 0150)
8	BPVL-1.93	SA-EQ-BPVL-1.93 (HB – SCM – 0193)
9	BPVL-2.50	SA-EQ-BPVL-2.50 (HB – SCM – 0250)
10	BPVL-3.00	SA-EQ-BPVL-3.00 (HB – SCP – 0300)
11	BPVL-4.00	SA-EQ-BPVL-4.00 (HB – SCM – 0400)
12	BPVL-5.15	SA-EQ-BPVL-5.15 (HB – SCM – 0515)
13	BPVL-6.00	SA-EQ-BPVL-6.00 (HB – SCP – 0600)
14	BPVL-8.80	SA-EQ-BPVL-8.80 (HB – SCP – 0880)
15	BPVL-10.00	SA-EQ-BPVL-10.00 (HB – SCP – 1000)
16	BPVL-13.00	SA-EQ-BPVL-13.00 (HB – SCM – 1300)
17	BPVL-16.00	SA-EQ-BPVL-16.00 (HB – SCM – 1600)
18	BPVL-21.00	SA-EQ-BPVL-21.00 (HB – SCM – 2100)
19	BPVL-25.00	SA-EQ-BPVL-25.00 (HB – SCM – 2500)
20	BPVL-35.00	SA-EQ-BPVL-35.00 (HB – SCM – 3500)
21	BPVL-41.00	SA-EQ-BPVL-41.00 (HB – SCM – 4100)
22	BPVL-50.00	SA-EQ-BPVL-50.00 (HB – SCM – 5000)
23	BPVL-70.00	SA-EQ-BPVL-70.00 (HB – SCP – 7000)
24	BPVL-95.00	SA-EQ-BPVL-95.00 (HB – SCM – 9500)
25	BPVLM-0.35	SA-EQ-BPVLM-0.35 (HB – SCP – 0035)
26	BPVLM-0.50	SA-EQ-BPVLM-0.50 (HB – SCP – 0050)
27	BPVLM-0.75	SA-EQ-BPVLM-0.75 (HB – SCP – 0075)
28	BPVLM-1.00	SA-EQ-BPVLM-1.00 (HB – SCM – 0100)
29	BPVLM-1.50	SA-EQ-BPVLM-1.50 (HB – SCM – 0150)
30	BPVLM-2.50	SA-EQ-BPVLM-2.50 (HB – SCM – 0250)

Also 1 core Shielded cable available

1.	Type Approval No.	:	1215
2.	Approval Title	:	Fuel Gauge Coaxial Cable (Equivalent to imported cable part No. S4006-12)
3.	Validity of Approval	:	30 Jun 2011
4.	Developer of the Item	:	M/s. Flu-Tef Industries Ahmadabad 382 445.
5.	Governing Specification	:	a) MIL-C-17G b) M17/93-RG178 c) Imported data sheet No. S4006-12 d) Product data sheet F 4006
6.	Characteristics of Wire		
	a) Classification	:	Fuel Gauge cable
	b) Voltage Rating	:	750 Vrms
	c) Operating Frequency	:	Up to 3 GHz
	d) Dielectric Strength	:	2000 Vrms for 1 minute
	e) Conductor	:	Solid Silver plated Copper clad steel wire
	f) Insulation	:	PTFE
	g) Temperature Range	:	-55°C to +200°C
7.	End Use of the Item	:	Used in Jaguar Aircraft in fuel gauging system. It interconnects the entire fuel tank unit (fuel probes) and fuel amplifier unit. Useful in high temperature and high frequency application



1. Type Approval No. : **1232**
2. Approval Title : **Polyimide+PTFE Insulated Electrical wires & Cables
Type SA-EQ-PTL-200/250/250 & SA-EQ-PTLE-200/250**
(Equivalent to Russian wire PTL- 2001250 and PTLE-2001250 respectively)
3. Validity of Approval : **30 Jun 2014**
4. Developer of the Item : M/s. Sanghvi Aerospace Pvt, Ltd.
Ahmadabad 382 405.
5. Governing Specification : a) TU-16-505.280-79 (Russian)
b) MIL-DTL-22759/86A
c) MIL-DTL-27500H
6. Characteristics of Wire
- a) Classification : External Heat Resistant
- b) Voltage Rating : 600V DC
- c) Operating Frequency : Up to 2000 Hz
- d) Conductor : Silver plated Copper Conductor
- e) Insulation : High Temperature Insulation (Flouro Plastic, Varnished Fibre Glass Sheath Insulation)
- f) Temperature Range : -60°C to +250°C
7. Decoding of Part No. of Wire : – PTL-200/250/250– wire heat resistant varnished
– PTLE – 200/250 - Same as PTL-200/250/250, with shielding
8. End Use of the Item : As heat resistant cable in engine harness, fire protection and high power electrical circuits

9. Other Details :

Sr. No.	Russian Part No	SAPTL Part No
1	PTL-200/250 – 0.35	SAPTL-200/250– 0.35
2	PTL-200/250 – 0.50	SAPTL-200/250– 0.50
3	PTL-200/250 – 0.75	SAPTL-200/250– 0.75
4	PTL-200/250 – 1.00	SAPTL-200/250– 1.00
5	PTL-200/250 – 1.50	SAPTL-200/250– 1.50
6	PTL-200/250 – 2.50	SAPTL-200/250– 2.50
7	PTL-200/250 – 4.00	SAPTL-200/250– 4.00
8	PTL-200/250 – 6.00	SAPTL-200/250– 6.00
9	PTL-200/250 – 10.00	SAPTL-200/250–10.00
10	PTL-200/250 – 16.00	SAPTL-200/250–16.00
11	PTL-200/250 – 25.00	SAPTL-200/250–25.00
12	PTL-200/250 – 35.00	SAPTL-200/250–35.00
13	PTL-200/250 – 50.00	SAPTL-200/250–50.00
14	PTL-200/250 – 70.00	SAPTL-200/250–70.00
15	PTL-200/250 – 95.00	SAPTL-200/250–95.00
Also 1 core Shielded cable available		

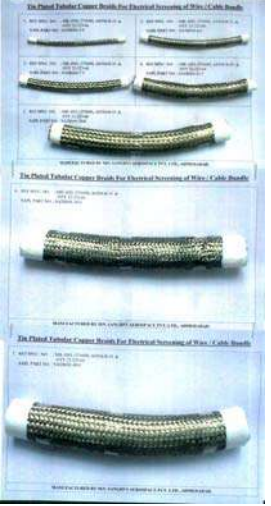
1.	Type Approval No.	:	1256																																								
2.	Approval Title	:	Tin Plated Tubular Copper Braids 7 -Types																																								
3.	Validity of Approval	:	30 Jun 2012																																								
4.	Developer of the Item	:	M/s. Sanghvi Aerospace Pvt, Ltd. Ahmadabad 382 405.																																								
5.	Governing Specification	:	a) MIL-DTL-27500H, b) ASTM-B-33 & c) Russian spec OTY 22-223-66																																								
6.	Characteristics of Wire	:	<ul style="list-style-type: none"> • Excellent Shield • Easy assembly / disassembly • Extra flexible • High expansion ratio (2:1) • Optical coverage: Min. 93% to max. 100% • Compatible with standard connectors 																																								
	a) Classification	:	Tin Plated Tubular Copper Braids																																								
	b) Tensile Strength	:	214 to 250 N/ mm ²																																								
	c) Elongation	:	16 to 27 (% min)																																								
	d) Electrical Resistance	:	0.01700 Ω* mm ² /m at 20 ⁰ C																																								
7.	End Use of the Item	:	Electrical screening on Aircraft electrical Wire/ Cable for project Takshak electrical looms in MiG 27 Upgrade (Electrical screening of wire / cable bundles of aircraft equipments / interconnect contact circuits to have low noise transmission of electrical signals through conductor.)																																								
8.	Other Details	:	Can be supplied in custom made size also Sanghvi Aerospace Part No . for Standard Sizes																																								
			<table border="1"> <thead> <tr> <th>Sr. No.</th> <th>Tin Plated Copper Braid</th> <th>Nickel Plated Copper Braid</th> <th>Silver Plated Copper Braid</th> </tr> </thead> <tbody> <tr> <td>1</td> <td>SATB101-3.0</td> <td>SATB103-3.0</td> <td>SATB102-3.0</td> </tr> <tr> <td>2</td> <td>SATB101-4.0</td> <td>SATB103-4.0</td> <td>SATB102-4.0</td> </tr> <tr> <td>3</td> <td>SATB101-6.0</td> <td>SATB103-6.0</td> <td>SATB102-6.0</td> </tr> <tr> <td>4</td> <td>SATB101-7.5</td> <td>SATB103-7.5</td> <td>SATB102-7.5</td> </tr> <tr> <td>5</td> <td>SATB101-10.0</td> <td>SATB103-10.0</td> <td>SATB102-10.0</td> </tr> <tr> <td>6</td> <td>SATB101-12.5</td> <td></td> <td>SATB102-12.5</td> </tr> <tr> <td>7</td> <td>SATB101-20.0</td> <td></td> <td>SATB102-20.0</td> </tr> <tr> <td>8</td> <td>SATB101-30.0</td> <td></td> <td>SATB102-30.0</td> </tr> <tr> <td>9</td> <td>SATB101-40.0</td> <td></td> <td>SATB102-40.0</td> </tr> </tbody> </table>	Sr. No.	Tin Plated Copper Braid	Nickel Plated Copper Braid	Silver Plated Copper Braid	1	SATB101-3.0	SATB103-3.0	SATB102-3.0	2	SATB101-4.0	SATB103-4.0	SATB102-4.0	3	SATB101-6.0	SATB103-6.0	SATB102-6.0	4	SATB101-7.5	SATB103-7.5	SATB102-7.5	5	SATB101-10.0	SATB103-10.0	SATB102-10.0	6	SATB101-12.5		SATB102-12.5	7	SATB101-20.0		SATB102-20.0	8	SATB101-30.0		SATB102-30.0	9	SATB101-40.0		SATB102-40.0
Sr. No.	Tin Plated Copper Braid	Nickel Plated Copper Braid	Silver Plated Copper Braid																																								
1	SATB101-3.0	SATB103-3.0	SATB102-3.0																																								
2	SATB101-4.0	SATB103-4.0	SATB102-4.0																																								
3	SATB101-6.0	SATB103-6.0	SATB102-6.0																																								
4	SATB101-7.5	SATB103-7.5	SATB102-7.5																																								
5	SATB101-10.0	SATB103-10.0	SATB102-10.0																																								
6	SATB101-12.5		SATB102-12.5																																								
7	SATB101-20.0		SATB102-20.0																																								
8	SATB101-30.0		SATB102-30.0																																								
9	SATB101-40.0		SATB102-40.0																																								

1.	Type Approval No.	:	1361																																																												
2.	Approval Title	:	PTFE + Polyimide+Glass Fibre Thread Insulated Nickel Electro Plated Copper Electrical Wires & Cables Type SABFS, SABFSE, SABFSEZ (equivalent to Russian wire BFS/BFSE/BFSEZ)																																																												
3.	Validity of Approval	:	31 Dec 2013																																																												
4.	Developer of the Item	:	M/s. Sanghvi Aerospace Pvt, Ltd. Ahmadabad 382 405.																																																												
5.	Governing Specification	:	TU 16-705.014-77 (Russian) & aircraft 9-12 overhaul manual																																																												
6.	Characteristics of Wire																																																														
	a) Classification	:	External Heat Resistant (Aircraft Fluid Resistant)																																																												
	b) Voltage Rating	:	350V DC or 250 AC																																																												
	c) Operating Frequency	:	Up to 2000 Hz																																																												
	d) Conductor	:	BFS : Stranded Nickel plated Copper / Copper alloy Conductor																																																												
	e) Insulation	:	Temp. resistant film, Skived PTFE film, Polyimide film with Fluoroplastic coating, fibre glass tape / thread impregnated with PTFE, Braiding of fibre glass threads coated with PTFE																																																												
	f) Temperature Range	:	-60°C to +250°C Short Term Exposure – upto +300°C																																																												
7.	Decoding of Part No. of Wire	:	– BFS – External heat & wear resistant, Fluoro plastic insulated cable – BFSE- Same as BFS, with shielding – BFSEZ – same as BFSE with protective jacket																																																												
8.	End Use of the Item	:	All type of Russian Aircrafts including Helicopter. For Fixed mounting of onboard power supply systems, aircraft harness, as heat & wear resistant cables																																																												
9.	Other Details	:	<table border="1"> <thead> <tr> <th>Sr. No.</th> <th>Russian Part No</th> <th>SAPL Part No</th> </tr> </thead> <tbody> <tr><td>1</td><td>BFS-0.20 br *</td><td>SABFS-0.20 br *</td></tr> <tr><td>2</td><td>BFS – 0.35</td><td>SABFS – 0.35</td></tr> <tr><td>3</td><td>BFS – 0.35 br *</td><td>SABFS-0.35 br *</td></tr> <tr><td>4</td><td>BFS – 0.50</td><td>SABFS – 0.50</td></tr> <tr><td>5</td><td>BFS – 0.50 br *</td><td>SABFS-0.50 br *</td></tr> <tr><td>6</td><td>BFS – 0.75</td><td>SABFS – 0.75</td></tr> <tr><td>7</td><td>BFS – 1.00</td><td>SABFS – 1.00</td></tr> <tr><td>8</td><td>BFS – 1.50</td><td>SABFS – 1.50</td></tr> <tr><td>9</td><td>BFS – 2.50</td><td>SABFS – 2.50</td></tr> <tr><td>10</td><td>BFS – 4.00</td><td>SABFS – 4.00</td></tr> <tr><td>11</td><td>BFS – 6.00</td><td>SABFS – 6.00</td></tr> <tr><td>12</td><td>BFS – 10.00</td><td>SABFS – 10.00</td></tr> <tr><td>13</td><td>BFS – 16.00</td><td>SABFS – 16.00</td></tr> <tr><td>14</td><td>BFS – 25.00</td><td>SABFS – 25.00</td></tr> <tr><td>15</td><td>BFS – 35.00</td><td>SABFS – 35.00</td></tr> <tr><td>16</td><td>BFS – 50.00</td><td>SABFS – 50.00</td></tr> <tr><td>17</td><td>BFS – 70.00</td><td>SABFS – 70.00</td></tr> <tr><td>18</td><td>BFS – 95.00</td><td>SABFS – 95.00</td></tr> <tr> <td colspan="3">1, 2 & 3 Core Shielded or Shielded & Jacketed Cable also available</td> </tr> </tbody> </table>	Sr. No.	Russian Part No	SAPL Part No	1	BFS-0.20 br *	SABFS-0.20 br *	2	BFS – 0.35	SABFS – 0.35	3	BFS – 0.35 br *	SABFS-0.35 br *	4	BFS – 0.50	SABFS – 0.50	5	BFS – 0.50 br *	SABFS-0.50 br *	6	BFS – 0.75	SABFS – 0.75	7	BFS – 1.00	SABFS – 1.00	8	BFS – 1.50	SABFS – 1.50	9	BFS – 2.50	SABFS – 2.50	10	BFS – 4.00	SABFS – 4.00	11	BFS – 6.00	SABFS – 6.00	12	BFS – 10.00	SABFS – 10.00	13	BFS – 16.00	SABFS – 16.00	14	BFS – 25.00	SABFS – 25.00	15	BFS – 35.00	SABFS – 35.00	16	BFS – 50.00	SABFS – 50.00	17	BFS – 70.00	SABFS – 70.00	18	BFS – 95.00	SABFS – 95.00	1, 2 & 3 Core Shielded or Shielded & Jacketed Cable also available		
Sr. No.	Russian Part No	SAPL Part No																																																													
1	BFS-0.20 br *	SABFS-0.20 br *																																																													
2	BFS – 0.35	SABFS – 0.35																																																													
3	BFS – 0.35 br *	SABFS-0.35 br *																																																													
4	BFS – 0.50	SABFS – 0.50																																																													
5	BFS – 0.50 br *	SABFS-0.50 br *																																																													
6	BFS – 0.75	SABFS – 0.75																																																													
7	BFS – 1.00	SABFS – 1.00																																																													
8	BFS – 1.50	SABFS – 1.50																																																													
9	BFS – 2.50	SABFS – 2.50																																																													
10	BFS – 4.00	SABFS – 4.00																																																													
11	BFS – 6.00	SABFS – 6.00																																																													
12	BFS – 10.00	SABFS – 10.00																																																													
13	BFS – 16.00	SABFS – 16.00																																																													
14	BFS – 25.00	SABFS – 25.00																																																													
15	BFS – 35.00	SABFS – 35.00																																																													
16	BFS – 50.00	SABFS – 50.00																																																													
17	BFS – 70.00	SABFS – 70.00																																																													
18	BFS – 95.00	SABFS – 95.00																																																													
1, 2 & 3 Core Shielded or Shielded & Jacketed Cable also available																																																															

1. Type Approval No. : **1434**
2. Approval Title : **PTFE Polyimide Insulated wires and Cables BPDO, BPDOE, BPDOU, BPDOUE**
3. Validity of Approval : **30 Jun 2014**
4. Developer of the Item : M/s. Sanghvi Aerospace Pvt, Ltd.
Ahmadabad 382 405.
5. Governing Specification : a) TU-16-505.941-76 (BPDO,BPDOE -Russian)
b) MIL-DTL-22759/86A
c) MIL-W-22759
d) MIL-DTL-27500H and SAPL Data Sheet
6. Characteristics of Wire
 - a) Classification : External Non Heat Resistant, Arc Tracking Resistant & Aircraft Fluid Resistant
 - b) Voltage Rating : 750 V DC
 - c) Operating Frequency : Up to 2000 Hz
 - d) Conductor : Silver Plated Copper / Copper alloy Conductor
 - e) Insulation : High Temperature Insulation
(Flurocarbon Polymer (FP) Insulation)
 - f) Temperature Range : -60°C to +200°C
7. End Use of the Item : All type of Russian Aircrafts including Helicopter as Hook-up wires in power, starting and propeller feathering circuits. The screened versions used in Radio, Fuel and Air-conditioning system of aircraft.
8. Other Details : Sanghvi Aerospace Part No. SA-EQ-BPDO / BPDOE and SA-EQ-BPDOU/ BPDOUE is equivalent to Russian wire BPDO/BPDOE & BPDOU/BPDOUE

Sr. No.	Russian Part No	SAPL Part No
1	BPDO-0.20	SA-EQ-BPDO-0.20
2	BPDOY-0.20	SA-EQ-BPDOY-0.20
3	BPDO-0.35	SA-EQ-BPDO-0.35
4	BPDOY-0.35	SA-EQ-BPDOY-0.35
5	BPDO-0.50	SA-EQ-BPDO-0.50
6	BPDOY-0.50	SA-EQ-BPDOY-0.50
7	BPDO-0.75	SA-EQ-BPDO-0.75
8	BPDO-1.00	SA-EQ-BPDO-1.00
9	BPDO-1.50	SA-EQ-BPDO-1.50
10	BPDO-2.50	SA-EQ-BPDO-2.50
11	BPDO-4.00	SA-EQ-BPDO-4.00
12	BPDO-6.00	SA-EQ-BPDO-6.00
13	BPDO-10.00	SA-EQ-BPDO-10.00
14	BPDO-16.00	SA-EQ-BPDO-16.00
15	BPDO-25.00	SA-EQ-BPDO-25.00
16	BPDO-35.00	SA-EQ-BPDO-35.00
17	BPDO-50.00	SA-EQ-BPDO-50.00
18	BPDO-70.00	SA-EQ-BPDO-70.00
19	BPDO-95.00	SA-EQ-BPDO-95.00

Also Shielded 1 core cable available

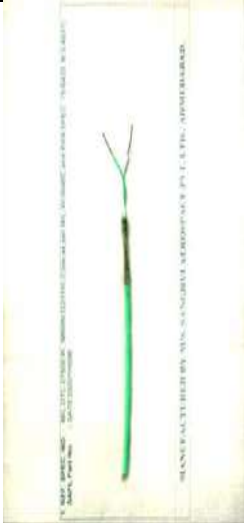
1.	Type Approval No.	:	1522	
2.	Approval Title	:	Thermo Couple Extension Cable Part No.SATE 3320 YH 006	
3.	Validity of Approval	:	31 Dec 2015	
4.	Developer of the Item	:	M/s. Sanghvi Aerospace Pvt, Ltd. Ahmadabad 382 405.	
5.	Governing Specification	:	a) MBBN 3320 YH, b) PAN Spec.SP-75-6420 c) BS4937 d) MIL-STD-27500H e) MIL-W-5846C f) ASTM-E-220	
6.	Characteristics of Wire			
	a) Classification	:	Excellent resistance to Aviation chemicals and fluids	
	b) Voltage Rating	:	600 Vrms	
	c) Wire Size	:	20 AWG	
	d) Insulation Resistance	:	$\geq 100M\Omega$	
	a) Thermo emf at 260°C	:	10.56 mV \pm 0.12 mV ($\pm 3^\circ\text{C}$) (Class 1) 10.56 mV \pm 0.06 mV ($\pm 1.5^\circ\text{C}$) (Class 2)	
	e) Conductor	:	Nickel Chromium (Plus wire) Nickel Aluminum (Minus wire)	
	f) Insulation	:	PTFE tape wrapped and sintered	
	g) Temperature Range	:	-55°C to +260°C	
7.	End Use of the Item	:	As thermocouple extension cable for use on LCA	

1.	Type Approval No.	:	1691																																																																																							
2.	Approval Title	:	Electrical Wires & Cables Type No. SAMS 16/16/26/36-13/33 SAMSE 16/26/36-13/33 And SAMSEO 16/26/36-13/33																																																																																							
3.	Validity of Approval	:	31 Dec 2016																																																																																							
4.	Developer of the Item	:	M/s. Sanghvi Aerospace Pvt, Ltd. Ahmadabad 382 405.																																																																																							
5.	Governing Specification	:	a) TU 16-505.083-78 Issue–Nil dated 09 Dec 2005 (Russian) b) SAPL Data Sheet																																																																																							
6.	Characteristics of Wire	:																																																																																								
	a) Classification	:	Internal Heat resistant wire. Indigenous Hook up wires, Fluid Resistant																																																																																							
	b) Voltage Rating	:	<ul style="list-style-type: none"> • 100V/250V/500V AC, • 150/350/700V DC 																																																																																							
	c) Operating Frequency	:	Upto 10000 Hz																																																																																							
	d) Conductor	:	Silver Plated Copper / Copper alloy Conductor																																																																																							
	e) Insulation	:	High Temperature Insulation. Fluro Plastic like PTFE taped and sintered Insulation																																																																																							
	f) Temperature Range	:	-60°C to +200°C																																																																																							
7.	Decoding of Part No. of Wire	:	<ul style="list-style-type: none"> – MS - Internal Heat Resistant Wire (M- Interior, S- Sintering Insulation) – MSE- Same as MS with Shielding – MSEO- Same as MSE with sheath 																																																																																							
8.	End Use of the Item	:	Use in Russian Fleet, Helicopters and Aircraft including MiG series and SU-30 MK-I aircraft. As Hook-up wires in aircraft starting system, fuel system and airborne missile launchers.																																																																																							
9.	Other Details	:	<table border="1"> <thead> <tr> <th>Sr. No.</th> <th>Russian Part No</th> <th>SAPL Part No</th> </tr> </thead> <tbody> <tr><td>1</td><td>MS 16–13–0.02</td><td>SAMS 16–13–0.02</td></tr> <tr><td>2</td><td>MS 16–13–0.03</td><td>SAMS 16–13–0.03</td></tr> <tr><td>3</td><td>MS 16–13–0.05</td><td>SAMS 16–13–0.05</td></tr> <tr><td>4</td><td>MS 16–13–0.08</td><td>SAMS 16–13–0.08</td></tr> <tr><td>5</td><td>MS 16–13–0.12</td><td>SAMS 16–13–0.12</td></tr> <tr><td>6</td><td>MS 16–13–0.20</td><td>SAMS 16–13–0.20</td></tr> <tr><td>7</td><td>MS 16–13–0.35</td><td>SAMS 16–13–0.35</td></tr> <tr><td>8</td><td>MS 16–13–0.50</td><td>SAMS 16–13–0.50</td></tr> <tr><td>9</td><td>MS 26–13–0.05</td><td>SAMS 26–13–0.05</td></tr> <tr><td>10</td><td>MS 26–13–0.08</td><td>SAMS 26–13–0.08</td></tr> <tr><td>11</td><td>MS 26–13–0.12</td><td>SAMS 26–13–0.12</td></tr> <tr><td>12</td><td>MS 26–13–0.20</td><td>SAMS 26–13–0.20</td></tr> <tr><td>13</td><td>MS 26–13–0.35</td><td>SAMS 26–13–0.35</td></tr> <tr><td>14</td><td>MS 26–13–0.50</td><td>SAMS 26–13–0.50</td></tr> <tr><td>15</td><td>MS 26–13–0.75</td><td>SAMS 26–13–0.75</td></tr> <tr><td>16</td><td>MS 26–13–1.00</td><td>SAMS 26–13–1.00</td></tr> <tr><td>17</td><td>MS 26–13–1.50</td><td>SAMS 26–13–1.50</td></tr> <tr><td>18</td><td>MS 26–13–2.50</td><td>SAMS 26–13–2.50</td></tr> <tr><td>19</td><td>MS 36–13–0.05</td><td>SAMS 36–13–0.05</td></tr> <tr><td>20</td><td>MS 36–13–0.08</td><td>SAMS 36–13–0.08</td></tr> <tr><td>21</td><td>MS 36–13–0.12</td><td>SAMS 36–13–0.12</td></tr> <tr><td>22</td><td>MS 36–13–0.20</td><td>SAMS 36–13–0.20</td></tr> <tr><td>23</td><td>MS 36–13–0.35</td><td>SAMS 36–13–0.35</td></tr> <tr><td>24</td><td>MS 36–13–0.50</td><td>SAMS 36–13–0.50</td></tr> <tr><td>25</td><td>MS 36–13–0.75</td><td>SAMS 36–13–0.75</td></tr> <tr><td>26</td><td>MS 36–13–1.00</td><td>SAMS 36–13–1.00</td></tr> <tr><td>27</td><td>MS 36–13–1.50</td><td>SAMS 36–13–1.50</td></tr> <tr><td>28</td><td>MS 36–13–2.50</td><td>SAMS 36–13–2.50</td></tr> </tbody> </table>	Sr. No.	Russian Part No	SAPL Part No	1	MS 16–13–0.02	SAMS 16–13–0.02	2	MS 16–13–0.03	SAMS 16–13–0.03	3	MS 16–13–0.05	SAMS 16–13–0.05	4	MS 16–13–0.08	SAMS 16–13–0.08	5	MS 16–13–0.12	SAMS 16–13–0.12	6	MS 16–13–0.20	SAMS 16–13–0.20	7	MS 16–13–0.35	SAMS 16–13–0.35	8	MS 16–13–0.50	SAMS 16–13–0.50	9	MS 26–13–0.05	SAMS 26–13–0.05	10	MS 26–13–0.08	SAMS 26–13–0.08	11	MS 26–13–0.12	SAMS 26–13–0.12	12	MS 26–13–0.20	SAMS 26–13–0.20	13	MS 26–13–0.35	SAMS 26–13–0.35	14	MS 26–13–0.50	SAMS 26–13–0.50	15	MS 26–13–0.75	SAMS 26–13–0.75	16	MS 26–13–1.00	SAMS 26–13–1.00	17	MS 26–13–1.50	SAMS 26–13–1.50	18	MS 26–13–2.50	SAMS 26–13–2.50	19	MS 36–13–0.05	SAMS 36–13–0.05	20	MS 36–13–0.08	SAMS 36–13–0.08	21	MS 36–13–0.12	SAMS 36–13–0.12	22	MS 36–13–0.20	SAMS 36–13–0.20	23	MS 36–13–0.35	SAMS 36–13–0.35	24	MS 36–13–0.50	SAMS 36–13–0.50	25	MS 36–13–0.75	SAMS 36–13–0.75	26	MS 36–13–1.00	SAMS 36–13–1.00	27	MS 36–13–1.50	SAMS 36–13–1.50	28	MS 36–13–2.50	SAMS 36–13–2.50
Sr. No.	Russian Part No	SAPL Part No																																																																																								
1	MS 16–13–0.02	SAMS 16–13–0.02																																																																																								
2	MS 16–13–0.03	SAMS 16–13–0.03																																																																																								
3	MS 16–13–0.05	SAMS 16–13–0.05																																																																																								
4	MS 16–13–0.08	SAMS 16–13–0.08																																																																																								
5	MS 16–13–0.12	SAMS 16–13–0.12																																																																																								
6	MS 16–13–0.20	SAMS 16–13–0.20																																																																																								
7	MS 16–13–0.35	SAMS 16–13–0.35																																																																																								
8	MS 16–13–0.50	SAMS 16–13–0.50																																																																																								
9	MS 26–13–0.05	SAMS 26–13–0.05																																																																																								
10	MS 26–13–0.08	SAMS 26–13–0.08																																																																																								
11	MS 26–13–0.12	SAMS 26–13–0.12																																																																																								
12	MS 26–13–0.20	SAMS 26–13–0.20																																																																																								
13	MS 26–13–0.35	SAMS 26–13–0.35																																																																																								
14	MS 26–13–0.50	SAMS 26–13–0.50																																																																																								
15	MS 26–13–0.75	SAMS 26–13–0.75																																																																																								
16	MS 26–13–1.00	SAMS 26–13–1.00																																																																																								
17	MS 26–13–1.50	SAMS 26–13–1.50																																																																																								
18	MS 26–13–2.50	SAMS 26–13–2.50																																																																																								
19	MS 36–13–0.05	SAMS 36–13–0.05																																																																																								
20	MS 36–13–0.08	SAMS 36–13–0.08																																																																																								
21	MS 36–13–0.12	SAMS 36–13–0.12																																																																																								
22	MS 36–13–0.20	SAMS 36–13–0.20																																																																																								
23	MS 36–13–0.35	SAMS 36–13–0.35																																																																																								
24	MS 36–13–0.50	SAMS 36–13–0.50																																																																																								
25	MS 36–13–0.75	SAMS 36–13–0.75																																																																																								
26	MS 36–13–1.00	SAMS 36–13–1.00																																																																																								
27	MS 36–13–1.50	SAMS 36–13–1.50																																																																																								
28	MS 36–13–2.50	SAMS 36–13–2.50																																																																																								

1.	Type Approval No.	:	1692																																																
2.	Approval Title	:	Electrical Wires & Cables Type No. SA-EQ-MS 16/26/36-P and SA-EQ-MSE 26-P																																																
3.	Validity of Approval	:	31 Dec 2016																																																
4.	Developer of the Item	:	M/s. Sanghvi Aerospace Pvt, Ltd. Ahmadabad 382 405.																																																
5.	Governing Specification	:	TU 16-505.195-80 dated 20 Sep 2003 (Russian)																																																
6.	Characteristics of Wire																																																		
	a) Classification	:	Internal Heat resistant wire. Indigenous Hook up wires, Fluid Resistant																																																
	b) Voltage Rating	:	<ul style="list-style-type: none"> • 100V/250V/500V AC, • 150/350/700V DC 																																																
	c) Operating Frequency	:	Up to 10000 Hz																																																
	d) Conductor	:	Silver Plated Copper Conductor																																																
	e) Insulation	:	High Temp Insulation like Fluro Plastic like PTFE Insulation																																																
	f) Temperature Range	:	-60°C to +200°C																																																
7.	Decoding of Part No. of Wire	:	<ul style="list-style-type: none"> – MS - Internal Heat Resistant Wire (M- Interior, S- Sintering Insulation) – MSE- Same as MS with Shielding 																																																
8.	End Use of the Item	:	Use in Russian Fleet, Helicopters and Aircraft including MiG series and SU-30 MK-I aircraft As Hook-up wires in aircraft starting system, fuel system and airborne missile launchers.																																																
9.	Other Details	:	<table border="1"> <thead> <tr> <th>Sr. No.</th> <th>Russian Part No.</th> <th>SAPL Part No</th> </tr> </thead> <tbody> <tr><td>1</td><td>MS 16 - P - 0.05</td><td>SA-EQ-MS 16 - P - 0.05</td></tr> <tr><td>2</td><td>MS 16 - P - 0.08</td><td>SA-EQ-MS 16 - P - 0.08</td></tr> <tr><td>3</td><td>MS 16 - P - 0.12</td><td>SA-EQ-MS 16 - P - 0.12</td></tr> <tr><td>4</td><td>MS 16 - P - 0.20</td><td>SA-EQ-MS 16 - P - 0.20</td></tr> <tr><td>5</td><td>MS 26 - P - 0.08</td><td>SA-EQ-MS 26 - P - 0.08</td></tr> <tr><td>6</td><td>MS 26 - P - 0.12</td><td>SA-EQ-MS 26 - P - 0.12</td></tr> <tr><td>7</td><td>MS 26 - P - 0.20</td><td>SA-EQ-MS 26 - P - 0.20</td></tr> <tr><td>8</td><td>MS 26 - P - 0.35</td><td>SA-EQ-MS 26 - P - 0.35</td></tr> <tr><td>9</td><td>MS 36 - P - 0.20</td><td>SA-EQ-MS 36 - P - 0.20</td></tr> <tr><td>10</td><td>MS 36 - P - 0.35</td><td>SA-EQ-MS 36 - P - 0.35</td></tr> <tr><td>11</td><td>MS 36 - P - 0.50</td><td>SA-EQ-MS 36 - P - 0.50</td></tr> <tr><td>12</td><td>MS 36 - P - 0.75</td><td>SA-EQ-MS 36 - P - 0.75</td></tr> <tr><td>13</td><td>MS 36 - P - 1.00</td><td>SA-EQ-MS 36 - P - 1.00</td></tr> <tr><td>14</td><td>MS 36 - P - 1.50</td><td>SA-EQ-MS 36 - P - 1.50</td></tr> <tr><td>15</td><td>MS 36 - P - 2.50</td><td>SA-EQ-MS 36 - P - 2.50</td></tr> </tbody> </table> <p>Also Shielded 1 core cable available in MS26-P Style</p>	Sr. No.	Russian Part No.	SAPL Part No	1	MS 16 - P - 0.05	SA-EQ-MS 16 - P - 0.05	2	MS 16 - P - 0.08	SA-EQ-MS 16 - P - 0.08	3	MS 16 - P - 0.12	SA-EQ-MS 16 - P - 0.12	4	MS 16 - P - 0.20	SA-EQ-MS 16 - P - 0.20	5	MS 26 - P - 0.08	SA-EQ-MS 26 - P - 0.08	6	MS 26 - P - 0.12	SA-EQ-MS 26 - P - 0.12	7	MS 26 - P - 0.20	SA-EQ-MS 26 - P - 0.20	8	MS 26 - P - 0.35	SA-EQ-MS 26 - P - 0.35	9	MS 36 - P - 0.20	SA-EQ-MS 36 - P - 0.20	10	MS 36 - P - 0.35	SA-EQ-MS 36 - P - 0.35	11	MS 36 - P - 0.50	SA-EQ-MS 36 - P - 0.50	12	MS 36 - P - 0.75	SA-EQ-MS 36 - P - 0.75	13	MS 36 - P - 1.00	SA-EQ-MS 36 - P - 1.00	14	MS 36 - P - 1.50	SA-EQ-MS 36 - P - 1.50	15	MS 36 - P - 2.50	SA-EQ-MS 36 - P - 2.50
Sr. No.	Russian Part No.	SAPL Part No																																																	
1	MS 16 - P - 0.05	SA-EQ-MS 16 - P - 0.05																																																	
2	MS 16 - P - 0.08	SA-EQ-MS 16 - P - 0.08																																																	
3	MS 16 - P - 0.12	SA-EQ-MS 16 - P - 0.12																																																	
4	MS 16 - P - 0.20	SA-EQ-MS 16 - P - 0.20																																																	
5	MS 26 - P - 0.08	SA-EQ-MS 26 - P - 0.08																																																	
6	MS 26 - P - 0.12	SA-EQ-MS 26 - P - 0.12																																																	
7	MS 26 - P - 0.20	SA-EQ-MS 26 - P - 0.20																																																	
8	MS 26 - P - 0.35	SA-EQ-MS 26 - P - 0.35																																																	
9	MS 36 - P - 0.20	SA-EQ-MS 36 - P - 0.20																																																	
10	MS 36 - P - 0.35	SA-EQ-MS 36 - P - 0.35																																																	
11	MS 36 - P - 0.50	SA-EQ-MS 36 - P - 0.50																																																	
12	MS 36 - P - 0.75	SA-EQ-MS 36 - P - 0.75																																																	
13	MS 36 - P - 1.00	SA-EQ-MS 36 - P - 1.00																																																	
14	MS 36 - P - 1.50	SA-EQ-MS 36 - P - 1.50																																																	
15	MS 36 - P - 2.50	SA-EQ-MS 36 - P - 2.50																																																	

1.	Type Approval No.	:	1740	
2.	Approval Title	:	Thermocouple Extension Cable Part Nos. No. SATE 3320 YH 004	
3.	Validity of Approval	:	31 Dec 2017	
4.	Developer of the Item	:	M/s. Sanghvi Aerospace Pvt, Ltd. Ahmadabad 382405.	
5.	Governing Specification	:	a) MBBN 3320 YH b) PAN Spec. 6420/SP-P-99300 c) BS 4937 d) MIL-W-5846C	
6.	Characteristics of Wire			
	a) Classification	:	-	
	b) Voltage Rating	:	600 Vrms	
	c) Thermo emf at 260°C	:	10.56 mV ± 0.12 mV	
	d) Conductor	:	Nickel Chromium (Plus Wire), Nickel Aluminum (Minus Wire)	
	e) Insulation	:	- PTFE Tape Wrapped - Polyimide Film Wrapped - PTFE Tape Wrapped and Sintered	
	f) Temperature Range	:	-55°C to +260°C	
7.	End Use of the Item	:	Use in Electrical looms of temperature sensors in Advance Light Helicopter.	
8.	Other Details	:	K-Type (Cromel / Alumel) Extension Cable	

1.	Type Approval No.	: 1815
2.	Approval Title	: Indigenous Mil-Std-1553B Data Bus Network for Bison Aircraft As a Substitute for Russian Supplied Mil-Std-1553B Data Bus Network 21.7771-40
3.	Validity of Approval	: 31 Dec 2018
4.	Developer of the Item	: M/s Compu power Pvt. Ltd., Hyderabad
5.	Governing Specification	: a) MIL 1553 B & b) Test Schedule No. AURDC/MIG-21 BISON/DOC/002
6.	Characteristics of Wire	
	a) Classification	: MIL BUS 1553 B
	b) Voltage Rating	: 600V
	c) Operating Frequency	: 1000 Hz
	d) Conductor	: -
	e) Insulation	: -
	f) Temperature Range	: -55 ⁰ C to 85 ⁰ C
7.	End Use of the Item	: Data communication purpose of various systems in Bison aircraft
8.	Other Details	: MIL-STD 1553B Data Bus Network developed by M/s. Compu Power Pvt. Ltd., Hyderabad as a substitute for Russian supplied MIL-STD 1553B Data Bus Network 21.7771-40



1.	Type Approval No.	:	1841																												
2.	Approval Title	:	Electrical Wires and Cables of type SABIFM / BIFM-N/SABIFM / BIFM-NE /SABIFM / BIFM-NEZ & SABIFM / BIFM-N-N / SABIFM / BIFM-NE-Z /SABIFM / BIFM-NEZ-N																												
3.	Validity of Approval	:	31 Dec 2019																												
4.	Developer of the Item	:	M/s. Sanghvi Aerospace Pvt, Ltd. Ahmadabad 382405.																												
5.	Governing Specification	:	a. TU16-505.945-76 b. MIL-DTL-81381C c. MIL-@-81381/12C d. MIL-DTL-27500H e. MIL-STD-2223 f. ASTM-B-355																												
6.	Characteristics of Wire																														
	a) Classification	:	External Heat Resistant Wire																												
	b) Voltage Rating	:	600 Volts DC																												
	c) Operating Frequency	:	Up to 2000 Hz																												
	d) Conductor	:	BIF - Silver plated Copper BIF-N - Nickel plated Copper																												
	e) Insulation	:	PI Tape Polyamide Fluoroplastic																												
	f) Temperature Range	:	-65 ^o C to +200 ^o C for BIF -65 ^o C to +260 ^o C for BIF-N																												
7.	Decoding of Part No. of Wire	:	<ul style="list-style-type: none"> - BIFM / BIFM-N – External wear resistant, Fluoro Plastic - BIFM / BIFM-NE- Same as BIF, with shielding - BIFM / BIFM-NEZ – same as BIFE / BIFE-N with protective jacket - BIFM / BIFM-N-N – External wear resistant, Fluoro Plastic - BIFM / BIFM-NE-N- Same as BIF-N, with shielding - BIFM / BIFM-NEZ-N – same as BIFE / BIFE-N-N with protective jacket 																												
8.	End Use of the Item	:	Used on Armament, Radar and Power Supply looms used in SU-30MKI Aircraft																												
9.	Other Details	:	<table border="1" style="width: 100%; border-collapse: collapse;"> <thead> <tr> <th style="text-align: center;">RUSSIAN PART NO. (Size in mm²)</th> <th style="text-align: center;">SAPL PART NO . (Size in mm²)</th> </tr> </thead> <tbody> <tr><td>BIFM / BIFM-N-0.20</td><td>SABIFM / BIFM-N -0.20</td></tr> <tr><td>BIFM / BIFM-N-0.20 br*</td><td>SABIFM / BIFM-N -0.20 br*</td></tr> <tr><td>BIFM / BIFM-N-0.35</td><td>SABIFM / BIFM-N -0.35</td></tr> <tr><td>BIFM / BIFM-N-0.35 br*</td><td>SABIFM / BIFM-N -0.35 br*</td></tr> <tr><td>BIFM / BIFM-N-0.50</td><td>SABIFM / BIFM-N -0.50</td></tr> <tr><td>BIFM / BIFM-N-0.50 br*</td><td>SABIFM / BIFM-N -0.50 br*</td></tr> <tr><td>BIFM / BIFM-N-0.75</td><td>SABIFM / BIFM-N -0.75</td></tr> <tr><td>BIFM / BIFM-N-1.00</td><td>SABIFM / BIFM-N -1.00</td></tr> <tr><td>BIFM / BIFM-N-1.50</td><td>SABIFM / BIFM-N -1.50</td></tr> <tr><td>BIFM / BIFM-N-2.50</td><td>SABIFM / BIFM-N -2.50</td></tr> <tr><td>BIFM / BIFM-N-4.00</td><td>SABIFM / BIFM-N -4.00</td></tr> <tr><td>BIFM / BIFM-N-6.00</td><td>SABIFM / BIFM-N -6.00</td></tr> <tr><td>BIFM / BIFM-N-10.00</td><td>SABIFM / BIFM-N -10.00</td></tr> </tbody> </table> <p>1, 2 & 3 Core Shielded & Shielded +Jacketed Cable also available.</p>	RUSSIAN PART NO. (Size in mm ²)	SAPL PART NO . (Size in mm ²)	BIFM / BIFM-N-0.20	SABIFM / BIFM-N -0.20	BIFM / BIFM-N-0.20 br*	SABIFM / BIFM-N -0.20 br*	BIFM / BIFM-N-0.35	SABIFM / BIFM-N -0.35	BIFM / BIFM-N-0.35 br*	SABIFM / BIFM-N -0.35 br*	BIFM / BIFM-N-0.50	SABIFM / BIFM-N -0.50	BIFM / BIFM-N-0.50 br*	SABIFM / BIFM-N -0.50 br*	BIFM / BIFM-N-0.75	SABIFM / BIFM-N -0.75	BIFM / BIFM-N-1.00	SABIFM / BIFM-N -1.00	BIFM / BIFM-N-1.50	SABIFM / BIFM-N -1.50	BIFM / BIFM-N-2.50	SABIFM / BIFM-N -2.50	BIFM / BIFM-N-4.00	SABIFM / BIFM-N -4.00	BIFM / BIFM-N-6.00	SABIFM / BIFM-N -6.00	BIFM / BIFM-N-10.00	SABIFM / BIFM-N -10.00
RUSSIAN PART NO. (Size in mm ²)	SAPL PART NO . (Size in mm ²)																														
BIFM / BIFM-N-0.20	SABIFM / BIFM-N -0.20																														
BIFM / BIFM-N-0.20 br*	SABIFM / BIFM-N -0.20 br*																														
BIFM / BIFM-N-0.35	SABIFM / BIFM-N -0.35																														
BIFM / BIFM-N-0.35 br*	SABIFM / BIFM-N -0.35 br*																														
BIFM / BIFM-N-0.50	SABIFM / BIFM-N -0.50																														
BIFM / BIFM-N-0.50 br*	SABIFM / BIFM-N -0.50 br*																														
BIFM / BIFM-N-0.75	SABIFM / BIFM-N -0.75																														
BIFM / BIFM-N-1.00	SABIFM / BIFM-N -1.00																														
BIFM / BIFM-N-1.50	SABIFM / BIFM-N -1.50																														
BIFM / BIFM-N-2.50	SABIFM / BIFM-N -2.50																														
BIFM / BIFM-N-4.00	SABIFM / BIFM-N -4.00																														
BIFM / BIFM-N-6.00	SABIFM / BIFM-N -6.00																														
BIFM / BIFM-N-10.00	SABIFM / BIFM-N -10.00																														



1.	Type Approval No.	:	1851
2.	Approval Title	:	100 Ohms Digital Video Cable, Part No. 1026A2S06-4CS06
3.	Validity of Approval	:	31 Dec 2019
4.	Developer of the Item	:	FLU TEF INDUSTRIES 89/7, PHASE - I, G.I.D.C. INDUSTRIAL ESTATE NR. FEROMATIC MALACRON, VATVA AHMEDABAD - 382 445.
5.	Governing Specification	:	a) MIL-C-17G b) ASTM-B- 298 & ASTM-B-624 c) MIL-W-16878 d) MIL-DTL-27500H e) RC/ALH/DSE/TS/0341, Issue-III, Rev-A dated 14-01-2008. f) QATP No. FT/QATP/DVC/ALH/02, Issue-02, Rev-01 dated 26-12-2007
6.	Characteristics of Wire		
	a) Classification	:	-
	b) Voltage Rating	:	1000 Volts RMS
	c) Operating Frequency	:	-
	d) Conductor	:	2 core twisted Stranded silver plated high strength copper alloy
	e) Insulation	:	PTFE taped & sintered and PTFE sheathed 4 pair cable
	f) Temperature Range	:	-50 ⁰ C to +200 ⁰ C
7.	End Use of the Item	:	For use on the Advanced Light Helicopter (ALH) In IADS configuration
8.	Other Details	:	Applicable only for LRUs, Assy, Sub Assy (Not Applicable if Fuel, Oil, Greases, Paints, Warnings, Raw material etc.).



Appendix – B

List of Provisional Clearances

100 OHMS DIGITAL VIDEO CABLE

FLU-TEF INDUSTRIES
TYPE 1026A2S06-4CS06

Electrical Characteristics :

Specification of :
HAL, RWR & DC

- Characteristics Impedance : 100 ± 10 ohms
- Maximum attenuation : 0.95dB/m at 650 Mhz
- Dielectric withstanding voltage : 1000 Vrms
- Operating temperature range : -50°C to 200°C

CONSTRUCTION DETAILS:

- A. Conductor : Stranded silver plated high Strength copper alloy.
- B. Insulation : PTFE taped & sintered
Twisting : 2 cores twisted
- C. Shield : Braided screen of silver plated copper wire (coverage 85 %)
- D. Inner Jacket : PTFE taped & sintered.
(Thickness : 0.25mm nom)
- E. Filler : PTFE rod filler
Twisting : 4 Individual jacketed cable twisted together with filler
- F. Shield : Overall braided screen of silver Plated copper wire.
(Coverage 85 %)
- G. Jacket : PTFE taped & sintered.
(Thickness : 0.30mm nom)

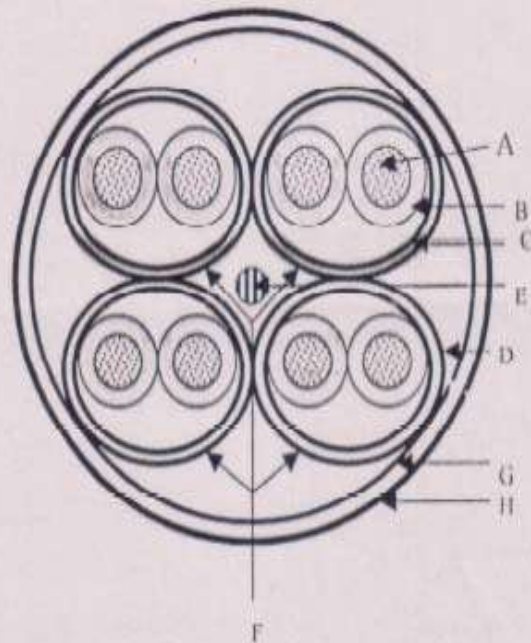

Binder tape may be used if necessary over a group of 4 twisted cable

Conductor AWG	No of strands X Strand diameter N X mm	Conductor diameter mm	Primary wire diameter mm	Filler diameter nominal mm	Screen over pair strand diameter mm	No of shielded & jacketed cables	Over all screen strand diameter mm	Finished cable	
								Max. Dia mm	Max. weight g/m
19/38	19x 0.10	0.50±0.013	1.39±0.05	1.4	0.10	4	0.10	10.0	150

1.	Provisional Clearance No.	:	RCMA(NSK)/PC/1175
2.	Approval Title	:	Twin Core Cable
3.	Validity of Approval	:	
4.	Developer of the Item	:	M/s INCAB Industries, Pune
5.	Governing Specification	:	a) TU-16-505-941-76 (Russian) b) MIL-DTL-22759/86 c) MIL-W-22759, d) MIL-DTL-27500H
6.	Characteristics of Wire		
	a) Classification	:	-
	b) Voltage Rating	:	--
	c) Operating Frequency	:	-
	d) Conductor	:	-
	e) Insulation	:	-
	f) Temperature Range	:	-
7.	End Use of the Item	:	For use on Pigtail of extension Lamp and Rear View Prism
8.	Other Details	:	

1.	Provisional Clearance No.	:	RCMA(NSK)/PC/1473
2.	Approval Title	:	Indigenous U- Cable part No. 310D/101168U for SARBE-8 system of Aircrew Survival Jacket (ASJ)
3.	Validity of Approval	:	29 Jan 2012
4.	Developer of the Item	:	M/s MerlinHawk Aerospace(P)Ltd, Bangalore
5.	Governing Specification	:	JSS 51100/MIL –C- 17G
6.	Characteristics of Wire		
	a) Classification	:	RF Co-axial cable
	b) Voltage Rating	:	1400 Vrms
	c) Operating Frequency	:	12.4 GHz
	d) Conductor	:	Silver plated copper clad steel (SCCS) or Silver plated copper (SPC)
	e) Insulation	:	Dielectric layer of spiral wrapped & fused PTFE Tape
	f) Temperature Range	:	- 55 ⁰ C to + 200 ⁰ C
7.	End Use of the Item	:	Used to connect the SARBE-8 Personal Rescue Beacon (PRB) to transmitter antenna carried in ASJ (Aircraft Survival Jacket) by the aircrew.
8.	Other Details	:	U CABLE SARBE – 8 Pt No.310D/101168U GIG No.1356063

1.	Provisional Clearance No.	:	RCMA/(N)/PC/1498
2.	Approval Title	:	Electrical cables of type BIFE / BIFE-N/BIFE / BIFE-NZ & BIFE / BIFE-N-Z/BIFE / BIFE-NZ-N
3.	Validity of Approval	:	22 Jul 2014
4.	Developer of the Item	:	M/s Sanghvi Aerospace(P)Ltd, Ahmadabad
5.	Governing Specification	:	a) TU-16-505.945-76 (Russian) b) MIL-DTL-81381/7 & 9, c) MIL-DTL-27500H
6.	Characteristics of Wire	:	
	a) Classification	:	External Heat Resistant Wire
	b) Voltage Rating	:	600 Volts DC
	c) Operating Frequency	:	Up to 2000 Hz
	d) Conductor	:	BIF - Silver plated Copper BIF-N - Nickel plated Copper
	e) Insulation	:	PI Tape
	f) Temperature Range	:	-65 ⁰ C to +200 ⁰ C for BIF -65 ⁰ C to +260 ⁰ C for BIF-N
7.	Decoding of Part No. of Wire	:	– BIF – External wear resistant, Fluoro Plastic – BIFE / BIFE-N- Same as BIF, with shielding – BIFE / BIFE-NZ – same as BIFE / BIFE-N with protective jacket – BIF-N – External wear resistant, Fluoro Plastic – BIFE / BIFE-N-N- Same as BIF-N, with shielding – BIFE / BIFE-NZ-N – same as BIFE / BIFE-N-N with protective jacket
8.	End Use of the Item	:	As aircraft armament, radar and airframe harness wires. These are heat and wear resistant cables
9.	Other Details	:	
	RUSSIAN PART NO. (Size in mm²)	SAPL PART NO . (Size in mm²)	RUSSIAN PART NO. (Size in mm²)
	BIFE / BIFE-N-0.20	SABIFE / SABIFE-N -0.20	BIFEZ / BIFENZ-0.20
	BIFE / BIFE-N-0.20 br*	SABIFE / SABIFE-N -0.20 br*	BIFEZ / BIFENZ-0.20 br*
	BIFE / BIFE-N-0.35	SABIFE / SABIFE-N -0.35	BIFEZ / BIFENZ-0.35
	BIFE / BIFE-N-0.35 br*	SABIFE / SABIFE-N -0.35 br*	BIFEZ / BIFEZ-N 0.35 br*
	BIFE / BIFE-N-0.50	SABIFE / SABIFE-N -0.50	BIFEZ / BIFEZ-N-0.50
	BIFE / BIFE-N-0.50 br*	SABIFE / SABIFE-N -0.50 br*	SABIFEZ / SABIFEZ-N -0.50 br*
	BIFE / BIFE-N-0.75	SABIFE / SABIFE-N -0.75	BIFEZ / BIFEZ-NZ-0.75
	BIFE / BIFE-N-1.00	SABIFE / SABIFE-N -1.00	BIFEZ / BIFEZ-N-0.75 br*
	BIFE / BIFE-N-1.50	SABIFE / SABIFE-N -1.50	BIFEZ / BIFEZ-N-1.00
	BIFE / BIFE-N-2.50	SABIFE / SABIFE-N -2.50	BIFEZ / BIFEZ-N-1.50
	BIFE / BIFE-N-4.00	SABIFE / SABIFE-N -4.00	BIFEZ / BIFEZ-N-2.50
	BIFE / BIFE-N-6.00	SABIFE / SABIFE-N -6.00	
	BIFE / BIFE-N-10.00	SABIFE / BIFE-N -10.00	

2 & 3 Core Shielded & Shielded +Jacketed Cable also available.

1.	Provisional Clearance No.	:	CEMILAC/3005/GDS/PC/051																								
2.	Approval Title	:	RF AND MICROWAVE CABLE ASSEMBLIES PART NOS. SPS-1501-394-SPS; SPS-1801-394-SPS; SPS-2301-394-SPS; SPS-2801-394-SPS; KPS-1501-394-KPS; KPS-1801-394-KPS AND TPS-1501-394-TPS																								
3.	Validity of Approval	:	24 Nov 2014																								
4.	Developer of the Item	:	M/s N.K.RF Products and Services Pvt Ltd., Bangalore																								
5.	Governing Specification	:	a) MIL-STD-17G (for cable) b) MIL-STD-348 & MIL-PRF -39012 (for Connector) c) MIL-STD-810F(Environmental)																								
6.	Characteristics of Wire																										
	a) Classification	:	RF cables																								
	b) Operating Voltage	:	1000 V																								
	c) Operating Frequency	:	- DC-18 GHz - DC-40 (KPS-1501-394-KPS) - DC-32 (KPS-1801-394-KPS)																								
	d) Conductor	:	Silver Plated OFHC Copper as per ASTM B-298																								
	e) Insulation	:	Multi-Ply Laminate Expanded PTFE Type F-6 as per Mil-C-17																								
	f) Temperature Range	:	- 65 ⁰ C to + 135 ⁰ C																								
7.	End Use of the Item	:	For airborne use																								
8.	Other Details	:	<table border="1"> <thead> <tr> <th>Part No.</th> <th>Nomenclature</th> <th>Nominal Diameter of cable</th> </tr> </thead> <tbody> <tr> <td>SPS-1501-394-SPS</td> <td>1501 cable assembly with SMA(M) connectors</td> <td>3.55 mm</td> </tr> <tr> <td>SPS-1801-394-SPS</td> <td>1801 cable assembly with SMA(M) connectors</td> <td>4.83 mm</td> </tr> <tr> <td>SPS-2301-394-SPS</td> <td>2301 cable assembly with SMA(M) connectors</td> <td>5.73 mm</td> </tr> <tr> <td>SPS-2801-394-SPS</td> <td>2801 cable assembly with SMA(M) connectors</td> <td>7.75 mm</td> </tr> <tr> <td>KPS-1501-394-KPS</td> <td>1501 cable assembly with 2.92 mm / K type connector</td> <td>3.55 mm</td> </tr> <tr> <td>KPS-1801-394-KPS</td> <td>1501 cable assembly with 2.92 mm / K type connector</td> <td>4.83 mm</td> </tr> <tr> <td>TPS-1501-394-TPS</td> <td>1501 cable assembly with TNC connector</td> <td>3.55 mm</td> </tr> </tbody> </table>	Part No.	Nomenclature	Nominal Diameter of cable	SPS-1501-394-SPS	1501 cable assembly with SMA(M) connectors	3.55 mm	SPS-1801-394-SPS	1801 cable assembly with SMA(M) connectors	4.83 mm	SPS-2301-394-SPS	2301 cable assembly with SMA(M) connectors	5.73 mm	SPS-2801-394-SPS	2801 cable assembly with SMA(M) connectors	7.75 mm	KPS-1501-394-KPS	1501 cable assembly with 2.92 mm / K type connector	3.55 mm	KPS-1801-394-KPS	1501 cable assembly with 2.92 mm / K type connector	4.83 mm	TPS-1501-394-TPS	1501 cable assembly with TNC connector	3.55 mm
		Part No.	Nomenclature	Nominal Diameter of cable																							
		SPS-1501-394-SPS	1501 cable assembly with SMA(M) connectors	3.55 mm																							
		SPS-1801-394-SPS	1801 cable assembly with SMA(M) connectors	4.83 mm																							
		SPS-2301-394-SPS	2301 cable assembly with SMA(M) connectors	5.73 mm																							
		SPS-2801-394-SPS	2801 cable assembly with SMA(M) connectors	7.75 mm																							
		KPS-1501-394-KPS	1501 cable assembly with 2.92 mm / K type connector	3.55 mm																							
		KPS-1801-394-KPS	1501 cable assembly with 2.92 mm / K type connector	4.83 mm																							
TPS-1501-394-TPS	1501 cable assembly with TNC connector	3.55 mm																									

Appendix– C

List of Manufacturers

SI No.	Cable Manufacturer & Address	Contact Details
1.	M/s Garg Associates Pvt. Ltd., 5, Nai Abadi GHAZIABAD, U.P	-
2.	M/s Metal Cloth Products Private Limited Flat No. 5/7, Hussainabad, No. 5 Langford Road, Langford Town BANGALORE – 560 025	Phone: +91-80-41121817 Fax: +91-80-22111859 E mail: sales@metalcloth.com
3.	INCAB Industries Limited, Cable House Hadapsar Industrial Estate PUNE – 411 013	Phone: 212 670011 (4 lines) Fax: 212 672045 TELEX: 145-243 NCAB IN
4.	M/s Mayfair Electricals, 177 Chittaranjan Avenue P.B.No. 6725 CULCUTTA - 7	Phone: 34 – 7071 34 – 5304 Telegram: MAFAIELEC
5.	M/s Jai Bharat Industries C-59/4, Okhla Industreis Area Phase II NEW DELHI – 110 020	Phone: 91-11-6848926, 6848373, 6862090 Fax: 91-11-6862830, 91-11- 6843767 E mail: jbi@theoffice.net
6.	Universal Cables Ltd., Post Box No. 9 Birla Vikas SATNA (MP) – 485 001	Bangalore office Phone: 3342484 / 3348179 Grams: 'UNISTAR' Telex: 0845-2653 U CLB IN Fax: 080-3348179
7.	M/s Sanghvi Aerospace Private Ltd., B/h, Lalit Warehouse Narol-Sarkhej Highway NAROLI AHMEDABAD – 382 405	Tel: +91-79-2535 07 56, 2532 34 60 Fax:+91-79-2535 87 38, 2539 41 00 E mail: info@sanghviaerospace.com Website:www.sanghviaerospac e.com
8.	M/s Radiant Cables Limited PB No. 1918, B1, Industrial Estate Sanathnagar, HYDERABAD – 500 018	Phone:91-40-23704470-73 Fax: 91-40-23703421 E mail: cables@radiantcorpn.com
9.	M/s Flu-Tef Industries 89/7 GIDC Estate, Phase 1, Near Torrent Lab, Vatva AHMEDABAD – 382 405	Tel: (F) 2583 1045, 2583 1405 (R) 2692 5926 Fax: (079) 2583 5623 2535 8738 E mail: flutefad1@sancharnet.in

10.	M/s Uniflex Cables Ltd., 158-163, GIDC, Umbergaon – 396 171 Dist. Valsad, GUJARAT	Phone : +91-260-2562412 / 2563412 / 2562954 / 2561354 / 2561212 Fax : +91-260-2562950 / 2563950
11.	M/s Compu Power Pvt Ltd., 8-2-350/2/B Road No.03 Banjara Hills HYDERABAD – 500 034	Phone: 91-40-23354583 Tel/Fax: 91-40-23352538 Fax:91-40-23394654 Email: compupowerindia@yahoo.com , jagadish@hd1.vsnl.net.in
12.	M/s. Merlin Hawk Aerospace Pvt. Ltd., # 57/5, 6 th Cross, Tank Bund Road, NS Palya, BTM Layout 2 nd Stage, BANGALORE – 560 076	
13.	M/s N.K.RF Products and Services Pvt Ltd. # 2, 2 nd Cross, Rustam Bagh, Off. Old Airport Road BANGALORE – 560 017	Tel: 080-2528 1840 / 2528 3350 Fax: 080-2528 0429

Appendix– D

Conversion Table for Cables

American Wire Gauge (AWG) Sizes and Properties Chart / Table

Table 1 lists the AWG sizes for electrical cables / conductors. In addition to wire size, the table provides values load (current) carrying capacity, resistance and skin effects. The resistances and skin depth noted are for copper conductors. A detailed description of each conductor property is described below Table 1.

Table 1: American Wire Gauge (AWG) Cable / Conductor Sizes and Properties

AWG	Diameter [inches]	Diameter [mm]	Area [mm ²]	Resistance [Ohms / 1000 ft]	Resistance [Ohms / km]	Max Current [Amperes]	Max Frequency for 100% skin depth
0000 (4/0)	0.46	11.684	107	0.049	0.16072	302	125 Hz
000 (3/0)	0.4096	10.40384	85	0.0618	0.202704	239	160 Hz
00 (2/0)	0.3648	9.26592	67.4	0.0779	0.255512	190	200 Hz
0 (1/0)	0.3249	8.25246	53.5	0.0983	0.322424	150	250 Hz
1	0.2893	7.34822	42.4	0.1239	0.406392	119	325 Hz
2	0.2576	6.54304	33.6	0.1563	0.512664	94	410 Hz
3	0.2294	5.82676	26.7	0.197	0.64616	75	500 Hz
4	0.2043	5.18922	21.2	0.2485	0.81508	60	650 Hz
5	0.1819	4.62026	16.8	0.3133	1.027624	47	810 Hz
6	0.162	4.1148	13.3	0.3951	1.295928	37	1100 Hz
7	0.1443	3.66522	10.5	0.4982	1.634096	30	1300 Hz
8	0.1285	3.2639	8.37	0.6282	2.060496	24	1650 Hz
9	0.1144	2.90576	6.63	0.7921	2.598088	19	2050 Hz
10	0.1019	2.58826	5.26	0.9989	3.276392	15	2600 Hz
11	0.0907	2.30378	4.17	1.26	4.1328	12	3200 Hz
12	0.0808	2.05232	3.31	1.588	5.20864	9.3	4150 Hz
13	0.072	1.8288	2.62	2.003	6.56984	7.4	5300 Hz
14	0.0641	1.62814	2.08	2.525	8.282	5.9	6700 Hz
15	0.0571	1.45034	1.65	3.184	10.44352	4.7	8250 Hz
16	0.0508	1.29032	1.31	4.016	13.17248	3.7	11 k Hz
17	0.0453	1.15062	1.04	5.064	16.60992	2.9	13 k Hz
18	0.0403	1.02362	0.823	6.385	20.9428	2.3	17 kHz
19	0.0359	0.91186	0.653	8.051	26.40728	1.8	21 kHz
20	0.032	0.8128	0.518	10.15	33.292	1.5	27 kHz
21	0.0285	0.7239	0.41	12.8	41.984	1.2	33 kHz
22	0.0254	0.64516	0.326	16.14	52.9392	0.92	42 kHz
23	0.0226	0.57404	0.258	20.36	66.7808	0.729	53 kHz
24	0.0201	0.51054	0.205	25.67	84.1976	0.577	68 kHz
25	0.0179	0.45466	0.162	32.37	106.1736	0.457	85 kHz
26	0.0159	0.40386	0.129	40.81	133.8568	0.361	107 kHz
27	0.0142	0.36068	0.102	51.47	168.8216	0.288	130 kHz
28	0.0126	0.32004	0.081	64.9	212.872	0.226	170 kHz
29	0.0113	0.28702	0.0642	81.83	268.4024	0.182	210 kHz
30	0.01	0.254	0.0509	103.2	338.496	0.142	270 kHz
31	0.0089	0.22606	0.0404	130.1	426.728	0.113	340 kHz
32	0.008	0.2032	0.032	164.1	538.248	0.091	430 kHz
33	0.0071	0.18034	0.0254	206.9	678.632	0.072	540 kHz
34	0.0063	0.16002	0.0201	260.9	855.752	0.056	690 kHz
35	0.0056	0.14224	0.016	329	1079.12	0.044	870 kHz
36	0.005	0.127	0.0127	414.8	1360	0.035	1100 kHz
37	0.0045	0.1143	0.01	523.1	1715	0.0289	1350 kHz
38	0.004	0.1016	0.00797	659.6	2163	0.0228	1750 kHz
39	0.0035	0.0889	0.00632	831.8	2728	0.0175	2250 kHz
40	0.0031	0.07874	0.00501	1049	3440	0.0137	2900 kHz

Part-II

CONNECTORS

Definitions & Interconnections Product Terms

Accessories: Mechanical devices, such as cable added to connector shells and other such hardware that are attach-able to connectors to make up the total connector configuration; while providing wire support and/or wire sealing.

Bayonet Coupling: A non-threaded, ramp type of coupling.

Cable Assembly: A cable with plugs or connectors on each end.

Configuration: Arrangement of contacts in a multiple-con-tact connector.

Contacts: Mechanical component to which electrical engagement is accomplished.

Contact Size: (Also known as Wire Gauge) - the largest wire that can be used with a specific contact.

Contact Spacing: The distance between the center-lines of adjacent contact areas.

Coupling Nut: Outer threaded or grooved ring which holds mated pair together.

Crimp Contact: A contact to which wire is joined by mechanical squeeze.

EMI or RFI Back shell: A type of accessory to terminate wire shielding.

Environmentally Sealed: Connector provided with gaskets, seals, potting or other devices to keep out moisture, dirt, air or dust that might reduce its performance.

Extraction/Removal Tool: A handheld tool used for removing a contact from a connector.

Fiber Optic Termini: Comparable to electrical pin and socket contacts, except they transmit data optically through fibers instead of electrically through wires.

Gland - Resilient ring in rear accessory, provides seal on jacketed cable

Grounding Fingers: A metal strap around plug shell for positive shell-to-shell conductivity/shielding.

Grommet: Resilient part at back of insert (attached or separate); gives wire moisture seal.

Hermetic: A connector with fused glass insert for air tightness.

Insert: The dielectric or insulating inner core, holds contacts.

Insert Arrangement: The number, spacing and arrangement of contacts in a connector.

Insertion Tool: A small, handheld tool used to insert contacts into a connector.

Interfacial Seal: A resilient part on the face of pin inserts which provides moisture seal.

Jam Nut: Hex nut that holds receptacle to a panel.

Mating Pair: Two connectors that couple together. Shell size insert arrangement and rotation must be compatible.

Mating/Unmating Forces: Torque required to couple/ uncouple a mating pair of connectors or contacts.

“O” Ring: Doughnut-shaped ring of rubber used as a seal around the mating insulator interface of cylindrical connectors.

Pin Contact: Male half of a mated pair of contacts
Plating - The metal finish applied to contacts and or shell components (protective) to resist corrosion and wear.

Plug: The cable/coupling half of a mating pair

Potting Boot: A type of accessory which forms a mold for potting compound

Rear Termination: An accessory which threads to back of shell

Receptacle: The panel/receiving half of a mating pair

Sealing Plug: Plastic type slug, placed in unused grommet holes to seal

Service Rating (Also known as Current Rating): The maximum voltage or current that a connector is designed to carry continuously.

Shell: Houses insert and contacts

Socket Contact: Female half of a mated pair of contacts

Solder Contact: A contact to which wire is joined by soldering. Has a cup, hollow cylinder, eyelet or hook to accept a wire for conventional soldered termination.

Strain Relief (Also known as Cable Clamp): A type of accessory which clamps wires for support.

Alternate Rotations: In cylindrical connectors: Rotation of either an insert or designated key/keyway locations (Alternate Keying) in a connector shell to a different angle than normal position. Allows for variations of mating two halves of cylindrical connectors.

Anodize: Formation of a protective, insulating oxide layer on metal by electrolytic action.

Arc Resistance: The characteristic of insulating materials to resist carbonization (also known as tracking) of the material surface between electrodes resulting from voltage breakdown.

Attenuation: (this term is used in Filters) The ratio of the input to output power levels in a network (transmission line) when it is excited by a matched source and terminated in a matched load.

Back-mounted: When a connector is mounted from the inside of a panel or box with its mounting flanges inside the equipment.

Circuit: A complete path or electron flow from a negative terminal of voltage source through a conductor and back to the positive terminal.

Closed Entry Socket Contacts: A female contact designed to prevent the entry of a pin or probing device having a cross-sectional dimension greater than the mating pin.

Coaxial Cable: A high-bandwidth cable consisting of two concentric cylindrical conductors with a common axis that is used for high speed data communication and video signals.

Compliant Contact: A press-fit type contact used to attach to a printed circuit board. Has an eyelet end.

Conductivity: The ability of a material to conduct electric current, expressed in terms of the current per unit of applied voltage. It is reciprocal of resistivity.

Contact Durability: Endurance measured by the number of insertion and withdrawal cycles that a connector withstands remaining within its specified performance level.

Contact Engaging and Separating Force: Force needed to either engage or separate pins and sockets when they are out of connector inserts. Values are generally established for maximum and minimum forces.

Contact Resistance: Maximum permitted electrical resistance of pin and socket contacts when assembled in a connector under typical service use.

Contact Retention: The minimum axial load in either direction that a contact must withstand while remaining firmly fixed in its normal position within the connector insert or housing.

Continuity: A continuous path for the flow of current in an electrical circuit.

Corrosion: The destruction of the surface of a metal by chemical reaction.

Coupling Torque: Force required to rotate a coupling ring or jackscrew when engaging a mating pair of connectors. .

Dielectric: Any insulating medium that intervenes between two conductors.

Dielectric Withstanding Voltage: Maximum potential gradient that a dielectric material can withstand without failure.

Discontinuity: A broken connection or the loss of a specific connection characteristic.

Edge Connector: One piece receptacle, containing female contacts designed to receive the edge of a printed circuit board and interconnect on which the male contacts are etched or printed. The connector may contain either a single or double row of female contacts.

Edgeboard Connector: connector that mates with printed wiring leads running to edge of a PC board.

Feed-through: A conductor that connects patterns on opposite sides of a PC board. Also called interfacial connection.

Fiber Optics: A data transmission medium consisting of glass fibers. Light-emitting diodes send light through the fiber to a detector, which then converts the light back into electrical signals.

First Article: A sample part or assembly manufactured prior to the start of production for the purpose of assuring that the manufacturer is capable of manufacturing a product that will meet the requirements.

Front-mounted: A connector is front-mounted when it is attached to the outside or mating side of a panel. (Can only be installed or removed from the outside of the equipment.)

Front Release Contacts: Connector contacts are released from the front side of the connector and then removed from the back wire side of the connector. The removal tool engages the front portion of the contact and pushes it out the back where it is removed by hand.

Harsh or Hostile Environment Connector: A connector designed and engineered for operation in hostile environment conditions, such as extreme high temperatures of 677°C (1,250°F), extreme low temperatures of absolute zero and severe water tight conditions.

Header: A feed through device that introduces a conductive path through an insulating plate.

Hermaphroditic Connector: Interconnecting device in which both mating parts are identical at their mating surfaces. (Also called Sexless Connector)

Hermaphroditic Contact: A contact in which both mating elements are precisely alike at their mating face.

Input/Output Connector: A mating pair of connectors used to carry signals into and out of a panel-mounted subsystem. An example is connector pair that interconnects the individual back panels in a large array of panels.

Insert Retention: Axial load in either direction that an insert must withstand without being dislocated from its normal position in the connector shell.

Insertion Force: The effort, usually measured in ounces, required to engage mating components.

Interchangeable: Characteristic of connectors in which one manufacturer's connector can be replaced by the connector of another manufacturer and provide the same function in the same panel space as the connector it is replacing.

Intermateable: Characteristic of connectors in which a connector half manufactured by one connector will mate directly with a connector half manufactured by a different company

Keying: Mechanical arrangement of guide pins and sockets, keying plugs, contacts, bosses, slots, keyways, inserts or grooves in a connector housing, shell or insert that allows connectors of the same size and type to be lined up without the danger of making a wrong connection.

Lanyard: A device attached to certain connectors that permit uncoupling and separation of connector halves by a pull on a wire or cable.

Life Cycle: A test that indicates the time span before failure; the test occurs in a controlled, usually accelerated, environment.

Mass Termination: Method of termination in which terminals that pierce flat cable insulation without stripping to cold flow mate with conductors and form a metal-to-metal joint.

Motherboard: A printed board used for interconnecting arrays of plug-in electronic modules.

Operating Temperature: Maximum internal temperature resistant capabilities of a connector in continuous service.

Outgassing: De-aeration or other gaseous emission from a printed board assembly (printed board, component of connector) when exposed to a reduced pressure or heat, or both.

Panel-mount: Fixing a connector half to a board, panel or frame. Usually, the female portion of the connector is mounted, and the male half is the removable portion.

Plated Through-Hole: A hole-formed deposition of metal on the sides of the hole and on both sides of the base to provide electrical connection from the conductive pattern on one side to that on the opposite side of the PC board.

Poke-Home Contact: Term applied to a male or female contact to which a wire has been permanently affixed prior to the assembly of the contact into the insert.

Positioner: Device attached to the crimping tool to position conductor barrels between the indenters.

Potting: Sealing of a component (for example the cable end of a multiple contact connector) with a plastic compound or material to exclude moisture, prevent short circuits and provide strain relief.

Pre-tinned: Solder applied to an electrical component prior to soldering.

Pre-tinned Solder Cup: Solder cups with inner surfaces that have been pre-coated with a small amount of tin lead solder or RoHS approved solder.

Press-fit Contact: Either a solid pin or a pin having a compliant member that makes an interference connection with a through-hole on a PC board. The pressure developed between interconnecting surfaces is sufficient to provide gas-tight electrical reliability without the use of solder.

Qualified Products List (QPL): A list of commercial products that have been pretested and found to meet the requirements of a specification, especially government specifications.

Quick-disconnect Coupling: A design feature, apparent in the quick-disconnect connector; it permits relatively rapid joining and separation.

RADSOK[®] Contact*: A unique socket contact design with a stamped and formed twisted inner grid. Socket cylinder within the female contact has several equally spaced longitudinal beams twisted into a hyperbolic shape. As male pin is inserted, axial members in the female half deflect, imparting high current flow across the connections.

Ramp: The sloped channel that accepts the detent pin in a bayonet connector.

Rear Release Contacts: Connector contacts are released and removed from the rear (wire side) of the connector. The removal tool engages the contact from the rear and pulls the contact out of the connector contact retainer.

Rear Seal: Design feature that provides an environmental seal at the rear of plug or receptacle.

Removable Contact: A contact that can be mechanically joined to or removed from an insert. Usually, special tools are required to lock the contact in place or remove it for repair or replacement.

RoHS (Restrictions of Hazardous Substances): The RoHS Directive bans the placing on the EU market of new electrical and electronic equipment containing more than agreed levels of lead, cadmium, mercury, hexavalent chromium, polybrominated biphenyl (PBB) and polybrominated diphenyl ether (PBDE) flame retardants.

Scoop Proof: Design feature whereby exposed contacts of a connector cannot be touched or damaged by any portion of the mating connector.

Serrations: Small grooves or indentations within a terminal wire barrel that increase the tensile strength and electrical conductivity of the crimped termination.

Soldering: Process of joining metallic surfaces with solder, without the melting of the base metals. Soldering is an economical, versatile and fast termination method. A soldered connection has metallic continuity and excellent long term reliability.

Splice Connector: A joint connecting conductors with good mechanical strength and good conductivity; a terminal that permanently joins two or more wires.

Surface Mounting: The electrical connection of components to the surface of a conductive pattern without utilizing component holes.

Thermal Shock: The effect of heat or cold applied to a material at such a rate that non-uniform thermal expansion or contraction occurs. In connectors, the effect can cause inserts and other insulation materials to pull away from metal parts.

Thermocouple Contact: A contact of special material used in connectors employed in thermocouple applications. Materials often used are iron, constantan, copper, chromel and alumel.

Tuning Fork Contact: U-shaped female contact that resembles a tuning fork. It can be stamped or formed.

Umbilical Connector: A connector used to connect cables to a rocket or missile prior to launching, and which is removed from the missile at the time of launching.

Wire-Wrapped Connection (Also known as Solder less Wrap): A solder less connection made by wrapping bare wire around a square or rectangular terminal with a power or hand tool.

CHAPTER I

1.0 Construction of Connectors

1.1 Nomenclature: Cylindrical Connectors

Basic Components

1. Shell (Houses Inserts & Contacts)
2. Insert (Dielectric Contact Insulator) Pin or Socket
3. Contact (Wire End Termination) (Electrical Engagement)
4. Coupling Nut
5. Accessories (Wire Seals, Cable Seals, Wire Support, etc.)

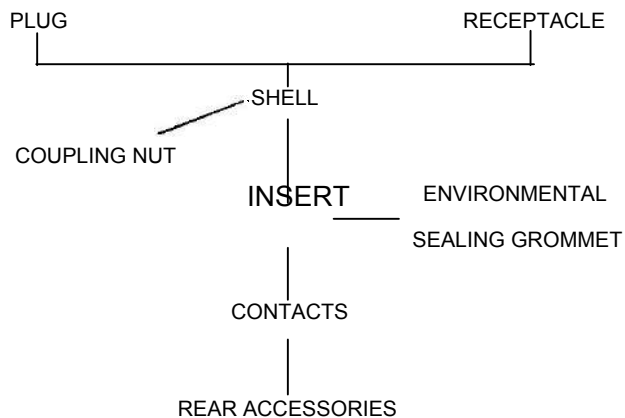

Mated Pair

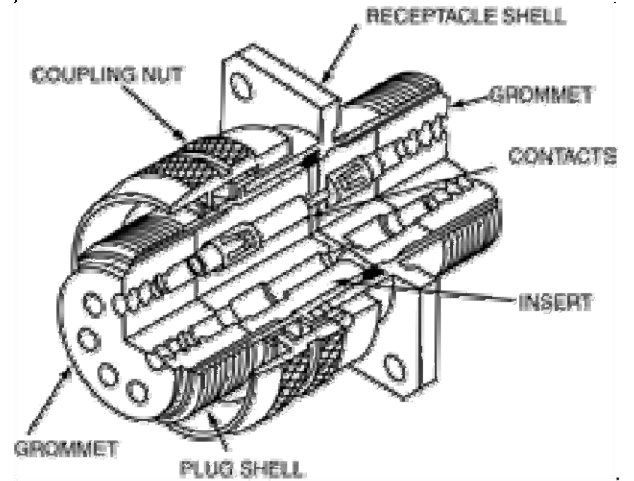

Rear Accessory

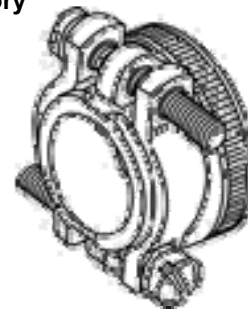

Shell Styles

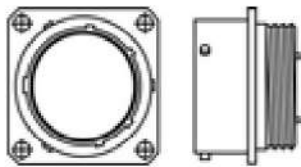

**WALL MOUNT RECEPTACLE
DESIGNATION: 00**

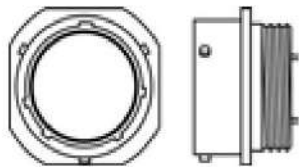

**LINE MOUNT RECEPTACLE OR
CABLE CONNECTING RECEPTACLE*
DESIGNATION: 01**

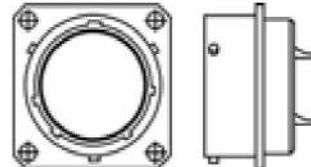

**BOX MOUNT RECEPTACLE
DESIGNATION: 02**

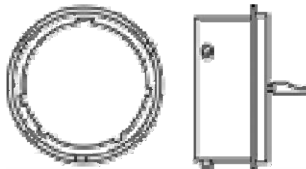

**SOLDER MOUNT RECEPTACLE
(HERMETIC)
DESIGNATION: IH**

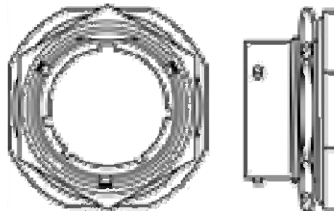

**JAM NUT RECEPTACLE
DESIGNATION: 07**

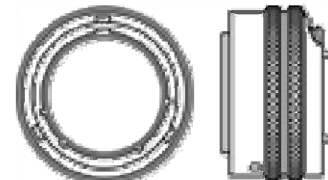

**STRAIGHT PLUG
DESIGNATION: 06**

1.2 Nomenclature: Cylindrical Connectors and Contacts

Shell Styles (Cont'd.)

Coupling

Threaded, Bayonet

Shell Sizes (Typical MIL-DTL-5015)

8S, 10S, 10SL, 12S, 12,
14S, 14, 16S, 16, 18
20, 22, 24, 28, 32, 36, 40, 44, 48

"S" designates short shell and short contacts

Shell size denotes mating thread diameter in 16ths of an inch. For example, a size 8 shell denotes 8/16 of an inch with a .5000-28 UNEF thread.

Style Designation

PLUG	SHELL STYLES
06	Straight
08	Angle
09	Flange Mount Receptacle
05	Straight, Less Rear Accessory
RECEPTACLE	SHELL STYLES
00	Wall Mount
01	Cable Connecting or Line Mount Receptacle
02	Box Mount
03	Wall Mount, Less Rear Accessory
04	Line Mount, Less Rear Accessory
07	Jam Nut
IH	Solder Mount Hermetic

Sizes by Wire Gauge, Examples:

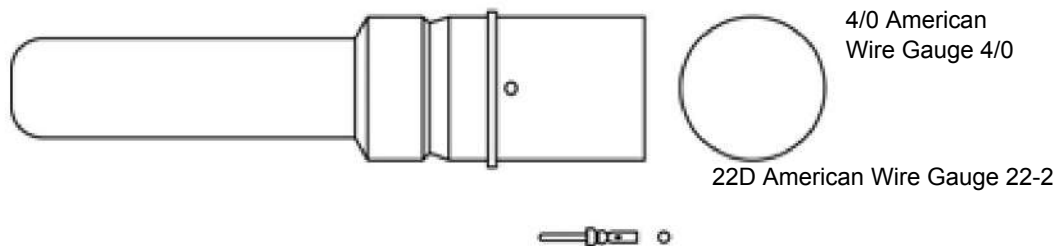

Inserts

Insert (Pin or Socket)

Insert & Grommet Assy.

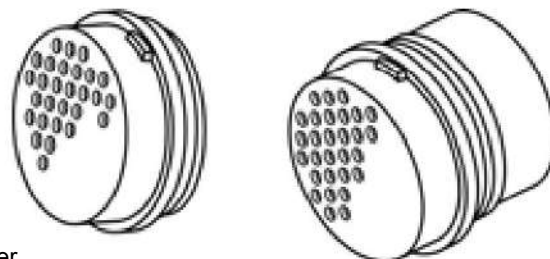

- Solder
- Crimp
- Metal Clip Retention
- Dielectric Retention

May include a soft front interfacial seal (Bonded) if dielectric is hard, and a rear sealing grommet separate or attached.

Contact and Contact Termination Style

Pin – Crimp*



Socket – Crimp*



Pin – Solder



Socket – Solder



Nomenclature: Cylindrical Connector and Contacts, cont.

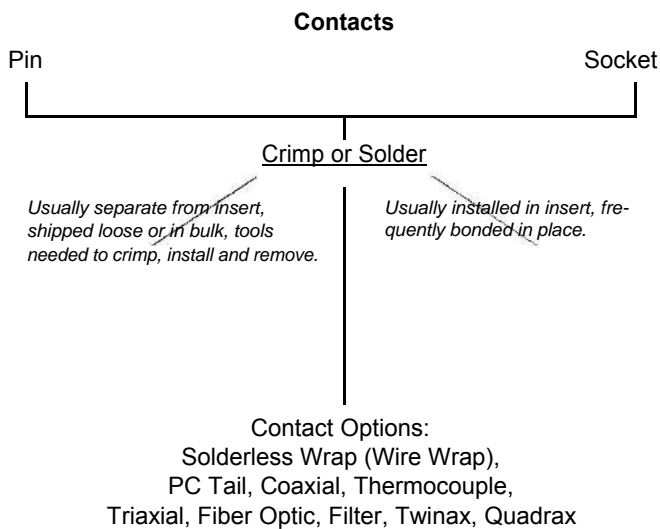

Contact Sizes

Contact Size	22D	22M	22	20	16
American Wire Gauge Wire Size (AWG)	22-28	24-28	22-26	20-24	16-20

Contact Size	12	8	4	0
American Wire Gauge Wire Size (AWG)	12-14	8-10	4-6	0-2

Accessories

- Adapters
 - straight, 90°, 75°
 - conduit, environmental, open wire bundle, EMI, etc.
- Compression ring – wire seal
- Clamp – cable sealing
- Stain relief – clamp, kellems grip
- Potting boot
 - Straight, angle, universal

Contact Versatility - Several types of Contacts can be designed into a Connector Shell

MIL-DTL-38999 connectors allow users to mix a variety of different power, signal, shielded, fiber optic and high speed contact styles within a common insert.

The insert arrangement below is an arrangement for Tri-Start MIL-DTL-38999 Series III connectors. It shows the variety of contacts that can be designed into a shell size 25. Typically, customers specify the contact sizes and power they require and choose an existing arrangement that fits their needs. For special new configurations, engineering will design the arrangement of contacts to fit within material and performance criteria.

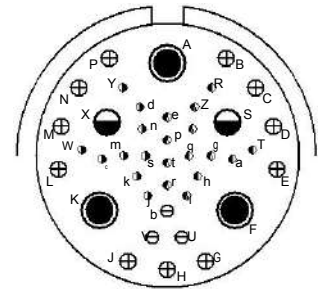

Insert Arrangement

25-41

Number of Contacts	22	3	11	2	3
Contact Size	22D	20	16	12 Coax	8 Twinax

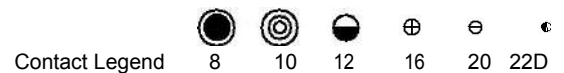

Contacts and Fiber Optic Termini for Cylindrical Connectors

Broad contact product range for Cylindrical Connectors includes:

- Standard 500 cycle and 1500 cycle, M39029 type power and signal contacts
- Crimp contacts for front or rear release connector applications
- Solder type, fixed contacts with cup or eyelet termination
- Thermocouple contacts
- Spring-loaded and push-pull types
- Filter contacts: Pi type tubular or Pi type planar for MF, HF, VHF, and UHF frequencies
- High frequency shielded coax, triax and twinax contacts
- High speed differential twinax and quadrax contacts
- For cylindrical connector attachment to Printed Circuit Boards:
 - PC tail contacts for signal and power applications, in coax, twinax, triax, differential twinax and quadrax designs
 - Compliant pin (Press fit) contacts
- Fiber optic Termini: MIL-T-29504 type or MT ferrules or ARINC 801 termini

1.3 TYPES OF CONNECTORS (Russian & MIL Specifications)

The various types of Russian connectors used in aircraft and equipments are as enumerated below:-

Sl. No.	Russian nomenclature	English translation	Fleet on which used
1.	ШР	SHR	MIG-29, AN-32, MI-8, MI-17 and LAUNCHERS (5P73)
2.	ШРr	SHRG	AN-32 & MI-8
3.	СШР	SSHR	LAUNCHER(5P73)
4.	2РТТ	2РТТ	MIG-23, MIG-27, AN-32
5.	РВН	RVN	AN-32
6.	Р	R	AN-32 & P-18 RADAR
7.	2РМ	2RM	MIG-23, MIG-27, MIG-29, and AN-32
8.	2РМТ	2RMT	MIG-23, MIG-27, MIG-29 and AN-32
9.	2РМД	2RMD	MIG-23, MIG-27, MIG-29 and AN-32
10.	2РМДТ	2RMDT	MIG-23, MIG-27, MIG-29 and AN-32
11.	2РМrПД	2RMGPD	MIG-23, MIG-27, MIG-29 and AN-32
12.	РП-15	RP-15	MIG-29
13.	РП -10	RP-10	ST -68 R(U)
14.	РС	RS	MIG-29
15.	РПКМ	RPKM	MIG-29
16.	СНц	SNTs	MIG-29
17.	2РТ	2RT	MIG-23 & MIG-29
18.	ШРА	SHRA	AN-32
19.	МС	MS	AN-32
20.	РРН	RRN	MIG-29
21.	ПnЛМ	SHPLM	MIG-29
22.	ШРАП	SHRAP	MI-8 MI-17, AN-32
23.	Зу	EU	MIG-23 & AN-32
24.	ХФ	KHF	MIG-29 & AN-32
25.	ОСШР	OSSHR	AN-32
26.	БМР	BMR	MIG-23

27.	БШЛ	BSHL	MIG-23
28	2РНД	2RND	MIG-23& MIG-29
29.	Г30-364-12Ty	GEO .364-126TU	KIPS (Msl testing vehicle)
30.	БТ3	BT3	SNR-125(Msl guidance radar)
31.	CP-50,CP-75	SR-50,SR-75	MIG-29,AN-32, PMGR & ST-68 R(U)
32.	Г3	GE	AN-32
33.	PT06A	PT06A	AN-32

1.3.1 CYLINDRICAL SHAPED NORMAL SIZE CONNECTORS-FOR ELECTRICAL RADIOAND ELECTRONIC EQUIPMENT (SHR, SHRG, SSHR, 2RTT)

These are cylindrical shaped low frequency, low voltage connectors. It covers the following range of connectors:-

- (a) SHR (b) SHRG (c) SSHR
(d) 2RTT (e) R

1.3.1.1 General characteristics:

The SHR, SHRG, SSHR, 2RTT, R are designed for connection and disconnection of electrical circuits in electrical and radio electronic equipment operating at DC or AC power having frequency up to 3 MHz.

The connectors include two parts i.e., a receptacle and a plug. The receptacle and the plug parts are drawn together by means of the thread provided on the receptacle insert and plug-coupling nut. This group of connector is classified on the basis of common unitized shells available in 10 different sizes.

Contact resistance of any joint of mated parts of these connectors is as follows:

Connector type	Contact diameter (mm)	Contact resistance, Ohms
SHR,SHRG SSHR,2RTT,R	1.5	0.0025
	2.5	0.001
	3.5	0.00075
	5.5	0.0003
	9.0	0.00015

Insulation resistance between any contact pairs and also between contactor body and any contact pair under normal condition (+20° c and RH 98%) is 1000 Mega ohms.

Internal diameter of connector receptacle shells (mm).

SHR, SHRG :	12(For unsealed connectors only) 20, 28,32,36,40,48,55,60
SSHR :	20, 28,32,36,40,48,55,60
R :	16(For unsealed connector only) 20, 28,32,36,40,48,55,60
2RTT :	12,16,20,28,32,36,40,48,55,60

Number of contacts.

SHR,SHRG :	1-10,12,14-16,20,23,26,30,31,35,45,47
SSHR :	2-4, 7, 10,15,20,26,30,45,50
R :	1, 4,7,9,14,17,28,38,47
2RTT :	1-10,12,14-16,20,23,26,30,31,35,45,47

1.3.1.2 Environmental characteristics

Environmental operating conditions of these connectors are as follows:-

Effects of environment	Values of affecting factor				
	SHR	SHRG	SSHR	R	2RTT
Max. Acceleration, g at vibration within frequency 5-2000 Hz.	30	30	30	30	10
Ambient temperature, °C	-60 to +60	-60 to +60	-60 to +85	-60 to +85	-60 to +100
Max. relative humidity, %	98	98	98	98	98

SHR

The decoding of part number SHR-12-P (PK,SK,U)-1-E-G-9 is as follows:-

SHR	Type of connector
12	Shell internal diameter
P	Receptacle without hood or Plug with straight end
PK	Receptacle with straight hood
SK	Receptacle with angle type hood
U	Plug with angle type hood

1	No. of contacts
E	Type of hood end nut (E for screened cable and N for not screened cable)
G	Types of contacts of socket (in receptacle), SH- pins
9	Arbitrary number of contact set

For example a connector with part number SHR-32-P-12-E-SH-1 means as follows:-

SHR	Type of connector
32	External diameter of housing
P	Plug with straight end
12	Number of contacts
E	Type of hood end nut for shielded cable
SH	Pins
1	Scheme number of locating pins (jacks)

SHRG

The decoding of part number SHRG-16-P-1-E-SH-8 is as follows:-

SHRG	Type of connector
16	Shell internal diameter (mm)
P	Without hood (PK-straight hood)
1	Number of contacts
E	Type of hood end nut for screened cable (N-for not screened cable)
SH	Type of contact pins in receptacle
8	Scheme number of locating pins

For example a connector of AN-32 aircraft having part number SHRG-32-PK-12-N-SH-1 means as follows:-

SHRG	Type
32	Shell internal diameter (mm)
PK	Straight type of hood
12	Number of contacts
N	Type of hood for not screened cable
SH	Pins i.e. type of contacts in receptacles
1	Scheme number of locating pins

2RTT

These are fixed mount connector used for high temperature tropical. The Decoding of part number 2RTT-48-B-P-E-20-SH-1 is as follows:-

2RTT	Type
48	Internal diameter of receptacle shell
B	Type of receptacle shell (K-plug shell)
p	Straight type hood (U-angle type)
E	Type of hood end nut for screened cable (N-for not screened)
20	No. of contacts
SH	Type of contacts in plug (SH-pins), In receptacle (G-socket)
1	Scheme number of locating pins

For example, a connector of MiG-23 aircraft having part no 2RTT-60 means as follows:-

2RTT	Type
60	Internal diameter of receptacle shell (mm)
B	Type of receptacle shell
47	No. of contacts
SH	Type of contacts in SH-pins
37	Scheme number of locating pins

SSHR

Decoding of SSHR type of connector is of similar nature as that SHRG With internal diameter of receptacle shell (mm) varies from 20, 28, to 60 and number of contacts 2,4,7,15,20,26,30,45,50.

1.3.2 CYLINDRICAL SHAPED SMALL SIZED CONNECTORS FOR ELECTRICAL AND RADIO ELECTRONIC EQUIPMENT (2RM, 2RMD)

These are cylindrical shape, low frequency, low voltage, small size connectors. The 2 RM & 2 RMD series connectors find their application in electrical and radio electronic equipment for high quality electrical connection. The 2 RM & 2 RMD connectors differ in the contact layout and are not interchangeable. The connector shells are unitized and have similar mounting and connection dimensions.

The RM series covers the following types:-

- (a) 2RM
- (b) 2RMG
- (c) 2RMGP
- (d) RMG
- (e) 2RMT

The RM series covers the following types:-

- (a) 2RMD
- (b) 2RMGD
- (c) 2RMGPD
- (d) 2RMDT

1.3.2.1 General characteristics

Unsealed connectors type 2RM, 2RMD, 2RMG, 2RMDT consist of receptacle and plugs. The receptacles are furnished with hoods for clamping of cables or for bunched conductor.

The sealed connectors of type 2RMG, 2RMGD, 2RMGP, 2RMGPD, RMG and RMGK are connector receptacles intended to provide a vacuum tight seal between outside and inside of an apparatus. 2RMG, 2RMGD, 2RMGP & 2RMGPD connectors have steel shells and glass insulator (insert with contact pins). Sealing is by fusing the glass to the metal. RMG & RMGK connectors have an insulator with pins moulded *in* it and are additionally sealed with epoxy compound .For better sealing of the shell the insulators of RMG connectors have a rubber sealing ring .The 2RM connectors are provided with contacts having nominal diameters of 1,1.5,2.0 and 3.0 . The 2RMDseries connectors employ contacts 1.5, 2.0 and 3.0 mm in diameter. Whose terminal lugs are 2 and 3 mm in diameter and is intended for connection of heavy conductors. T connector contacts are plated with gold, silver, palladium, and nickel (for sealed parts connector only).

Bore diameter of connector receptacle shells (mm)

- (a) Series 2RM : 14,18,22,24,27,30,33,36,39,42
- (b) Series 2RMD types
 - (i) 2RMD, 2RMDT : 18, 24, 27,30,33,36,39,42,45
 - (ii) 2RMGD : 18, 24, 27, 30, 33,36,39,42
 - (iii) RMGPD : 18, 24, 27, 30, 33,36,39,42

Number of contacts:-

- (a) Series 2RM : 4,7,10,19,20,22,24,30,32,45,50
- (b) Series 2RMD types
 - (i) 2RMD, 2RMDT : 4,7,8,10,19,20,22,24,32,45,50
 - (ii) 2RMGD : 4, 7, 8,10,19,20,22,24,32
 - (iii) RMGPD : 4, 7, 8,10,19,20,22,24,32

Specifications

The specifications of 2RM and 2RMD series of connectors are as follows:-

- (a) Operating temperature -60 to +100⁰ C for connectors with silver-plated contacts and -60⁰ C for gold plated contacts.
- (b) Type of terminating wire into contact: "Soldering".

2RM

The decoding of part number 2RM-14-B-P-E-20-G-4-V-1-L is as follows:

2RM	Type of connector
14	Shell diameter from the contact terminal end
B	Receptacle
P	Straight barrel (U-angle type)
E	View of end barrel nut for screened cable (N-for Unscreened)
20	No. of contacts
G	Type of contacts (G-for sockets, SH-for pins)
4	Scheme no of locating pins
V	Contacts plating silver (A-gold, E-nickel)
1	Temperature rating +100 ⁰ C (2-upto +200 ⁰ C)
L	Left Receptacle

2RMD

These are small sized, high temperature through type connectors used for long circuits. The decoding of part number 2RMD-45-K-P-N-50-G-5- V-I is as follows:

2	Number of development
R	Connector
M	Small sized
D	For long circuits
45	External diameter of casing (mm)
K	Cable
p	Straight (U-angular)
N	Unshielded (E – shielded)
50	No of contacts
G	Jacks (SH – pins)
5	Scheme number of locating pins
V	Silver plating of contacts
1	100°c

2RMGPD

These are hermetically sealed through type connectors used for long circuits. Connector with part number 2RMGPD-42-K-P-N-50-SH-2-A-1 means as follows:

2RM	Type of connector
G	Hermetically sealed
P	Through type
D	For long circuits
42	External diameter of connector
K	Cable (B-unitized)
p	Straight branch pipe (U-angular)
N	Unshielded (E-shielded)
50	Number of contacts
SH	Pins (G-Jacks)
2	Scheme number of locating pins
A	Coating of contacts gold plating (B-silver plated, E-nickel plated, P-palladium plated)
1	Temperature rating up to 100 ⁰ C (2-up to 200 ⁰ C)

1.3.3 RECTANGULAR SHAPED COMBINED CONNECTORS (RP-15) :

1.3.3.1 General characteristics

The RP-15, rectangular shape combined connectors are used for electrical connection of MiG-29 aircraft in low frequency and high frequency circuits of electrical and radio electronic equipment. The connectors are assigned designation including numbers and letters that stand for certain classification features. Composition of designation and their decoding is explained in the succeeding paragraphs.

Specification

- (a) Contact resistance of high frequency contacts and joint between shells is 0.01 Ohms.
- (b) Insulation resistance under normal conditions is 5000 Mega ohms
And at raised temperature are 50 Mega ohms.
- (c) Ambient temperature is from -60°C to + 125°C.
- (d) Maximum permissible value of 'g' at vibration of frequency of 5000 Hz
Is 50g.

Coding of part number

The decoding of part number RP-15-9-SH-A-I-K. Means as follows: -

- RP : Connector type
- 15 : Serial no assigned to given construction
- 9 : Number of low frequency contacts including
10,14,15,23,32,36,50
- SH : Type of contact pins (G --sockets)
- A : Gold plating (V- silver)
- 1 : Arbitrary number of high frequency contacts
- K : Use of hood for clamping of cables or use of a locking device
to lock The connector in a mated state.

For example a connector of MiG -29 aircraft having part number RP-15-23-Sh-V means as follows:-

- RP : Connector type
- 15 : Serial number assigned to type of construction
- 23 : No of low frequency contacts

Sh	:	Type of contact pins
V	:	Plating metal (Silver)

1.3.4 CYLINDRICAL SHAPED SUBMINIATURE CONNECTORS FOR ELECTRICAL AND RADIO ELECTRONIC EQUIPMENT (TYPE -RS) :

These are cylindrical shaped low frequency, low voltage subminiature connectors. The RS series connectors are intended for electrical connections in electrical and radio equipment. The connectors are subdivided into internal, inter-unit, unsealed and sealed. Internal connectors consist of an equipment plug and a cable socket, which are coupled by means of a union nut. The inter-unit connectors include two-equipment parts i.e., a plug and a receptacle for plug-in connections. The connector is automatically plugged in and withdrawn when the units or assemblies are interconnected.

1.3.4.1 General characteristics

The equipment plug is available in two versions "sealed" and "unsealed". The unsealed connectors are RS, RSA, RST, RSAT and sealed tropicalised connectors are RSG, RSGA, RSGT and RSGT. The super sealed connectors are RSGS and RSGSP.

Classed with the inter unit connectors are tropicalised unsealed connectors of type RSB, RSBA, RSBT and RSBAT. The sealed tropicalised connectors are RSGB, RSGBA, RSGBT and RSGBAT. Unsealed connectors have unsealed plugs and receptacles. Sealed connectors have sealed plugs mating with unsealed receptacles. There are 18 types of RS series connectors based on construction and application. Except RSGS and RSGSP each type of connector has six different sizes, whereas RSGS has four different sizes and RSGSP has three different sizes.

Specifications

Operating voltage ranges from 1 mV to 200 V. Minimum current is from 1 μ A at a contact circuit electro-motive force of not less than 1mV for connectors having gold plated contacts; 1 μ A at 0.1 V for connectors furnished with silver plated contacts; and to 10 μ A at 0.2 V for the connectors of types RSGS and RSGSP.

. The ambient temperature varies from -60°C to +85° C for RS series connector except -60°C to + 100°C for RSGS and RSGSP.

Decoding of part number

A connector with part number RS-19-A for internal connections means as follows:

- RS : Unsealed type of connector (RSG, RSGS & RSGSP - sealed)
- 19 : Number of contacts (RSG : 7, 10,19,32,50.
RSGS : 10,19,30,50 RSGSP: 19, 32 and 50)
- A : Gold- plated contact plating
(Silver plated contacts have no designation)

For example Part no RS-19-B-A for inter unit connections means as follows:-

- RS : Unsealed type of Connector
- 19 : Number of contacts
- B : Inter unit connector
- A : Gold plated contact plating

1.3.5 CYLINDRICAL SHAPED, LOW-VOLTAGE CONNECTORS (TYPE RVN2, RVN3)

The cylindrical connectors, type RVN2 and RVN3 are used for low voltage DC or AC up to frequency of 3 MHz. The connector consists of 2 parts i.e., a plug and a receptacle. Connectors have a catch, which locks it in the inserted position and provides quick easy insertions and withdrawals.

1.3.5.1 General characteristics

All connector contacts are 1 mm in diameter. Type RVN2 & RVN3 connectors are similar in constructions. They differ only in the contact plating. The RVN2 connectors have silver-plated contacts, while the contact of RVN3 connector is gold plated. Each type has two no of contacts 5 & 7. The plugs and receptacles are assigned designation letter depending on classification.

Specifications

- (a) Current drawn for connector with 5 contact is 13 Amps and with 7 Contact is 15 Amps.
- (b) Minimum current per contact is 1 μ A and maximum is 5 A.
- (c) Operating voltage (amplitude value) min. is 1 mV & max 300V.
- (d) Contact overheating temperature (max) is 15° C.
- (e) Contact resistance (max) is 0.005 ohms & insulation resistance is 1000 Mega Ohm
- (f) Ambient temp is -60°C to +85°C.

Decoding of part number

A Connector with part number **RVN2-5-1-SH-7** means as follows: -

- RVN2 : Type of silver-plated contacts (RVN3 - for gold plated- Contacts)
- 5 : Number of contacts
- 1 : Scheme number of locating the pins
- SH : Contact pins (G -for contact of socket)
- 7 : Type of Shell (Cable with straight barrel for unscreened Cable)

1.3.6 CYLINDRICAL SHAPED LOW FREQUENCY SMALL SIZE, ELECTRIC COUPLERS (SNTs) :

The SNTs subminiature connectors are low frequency, low voltage, cannon size, bayonet type, multi position electric couplers of all climate design, with gold plated contacts connected to the wires by crimping. They are used for mechanical coupling uncoupling the AC and DC electric circuits having the frequency of up to 3 MHz, voltage up to 700V.

1.3.6.1 General characteristics

The SNTs 23 couplers have gold plated separable (detachable) contacts, which are connected to the wires by squeezing. They are intended for the internal wiring of the boxes. The delivery set of coupler SNT 23 placed in one PVC bag includes the following: -

- (a) The plug or receptacle without holders and shells.
- (b) The holder or shell (straight or angular) and the set of contacts.

- (c) The set of sealing plugs provided, for the holes in the rubber insulators are for installing the contacts not coupled with the wires.
- (d) The mounting tools for installing and removing the contacts coupled with the wires.

Specifications

(a) Type of terminating wire into contacts is by crimping. Diameters of contacts and wire cross sections is 1 mm (0.2-0.75mm²), 1.5 mm to (0.75-1.5) mm², and 2mm to (2.5-4) mm².

(b) Grades of wire terminated into connectors are "wires with solid insulation, grades BPDO, BIF, BFS and MS.

(c) The operating temperature of these type of connectors is -60°C to + 105°C

Decoding of part number

For example a connector with part number SNTs 23-4-14-V(R)-1-a (6, b, g) – v means as follows: -

SNTs 23	:	Type of connector
4	:	Number of contacts
14	:	Conventional dimensions of casing
V(R)	:	Connector parts (V-plug, R-receptacle)
1	:	Indicates design features
1	:	instrument section without housing
2	:	instrument section with straight housing
4	:	instrument section with angular housing
6	:	cable section with straight housing
8	:	cable section with angular housing
11	:	cable section without housing
12	:	instrument section with holder for heat shrinkage she
13	:	cable section with holder for heat shrinkage shoe
a (x ,b ,g)	:	Angular position of insulator in connector casing (with The insulator placed in normal position the letter index is Absent.

V : All weather construction.

A connector with part number SNT 23-4- V-2-a- V means as follow: -

S	:	Connector
N	:	Low frequency
Ts	:	Cylindrical

4	:	Number of contacts (3, 7, 10, 19, 24, 28, 32, 41, 43, 55, 61)
V	:	Plug
2	:	Instrument section with straight housing
a	:	Angular position of insulator in connector casing
V	:	All weather

1.3.7 HEAT RESISTANT THREADED CONNECTORS, (TYPE: 2RT) :

These are heat resistant threaded type straight or angular connectors and are used in electrical connections of Mig -23 and Mig -29 aircraft electrical circuits.

Specifications

- (a) The operating temperature of these type of connector is -60°C to $+100^{\circ}\text{C}$
- (b) Type of terminating wire into contact is soldering.
- (c) Diameters of contacts and wire cross-section corresponding to
These types of connectors are 1.5 mm & $0.35\text{-}1.5\text{ mm}^2$ and
 2.5 mm & $0.35\text{-}2.5\text{ mm}^2$.
- (d) Grades of wire terminated into connectors can be of any grades.

Decoding part number

A connector with part number 2RT-20-PK-9-N-Sh-8-A means as follows:-

2RT	:	Threaded connectors
T	:	Heat resistant
20	:	External diameter of casing (mm) 12, 16, 20, 28, 32, 36, 40, 48, 55, 60
P	:	Instrument section without branch pipe
PK	:	With straight branch pipe (UK- With angular one)
9	:	Number of contacts
N	:	Unshielded (E - Shielded)
Sh	:	Pins (G - socket)
8	:	Scheme of locating contacts
A	:	Material of insulator

1.3.8 RECTANGULAR SHAPED SMALL SIZED LOW & HIGH FREQUENCY COMBINED CONNECTORS (RPKM)

These type of connectors are used in low and high frequency electrical and radio electronic equipment of MiG -29 aircraft electrical circuits.

Specifications

- (a) The operating temperature of these type of connector is. -60°C to + 100°C.
- (b) The type of terminating wire into contacts is by soldering.
- (c) Diameter of contact and wire cross-section of these connectors is For Low and high frequency contacts.

Decoding of part numbers

A connector with part number RPKMI-57-SH-1 means as follows: -

- R : Connector
- P : Rectangular
- K : Combined
- M : Small sized
- 1 : Single connector with silver-plated contact
2 - Single connector .with gold plated contact
3 - Paired connector with silver- plated contact
4 - Paired connector with gold- plated contact
- 57 : Number Of contacts
- SH : Plug (G - receptacle)

1.3.9 RECTANGULAR SHAPE LOW-FREQUENCY LOW-VOLTAGE CONNECTORS TYPE (RP-10) :

1.3.9.1 General characteristics

The RP-10 connectors are intended for electrical connection in electrical and radio electronic equipment. The connectors are available for mounting on equipment. The plugs have hoods with terminals for attachment of the cable. To lock the plugs and receptacles in the mated position the connector receptacles are furnished with special lock nuts at the plugs

have locking pins. The connectors are assigned designations composed letters and numbers which correspond to a certain classification features.

Specifications

- (a) The current per contact min is 0.001 Amp and max is 15 Amp.
- (b) Insulation resistance under normal conditions is 1000 Mega ohm.
- (c) Ambient temperature is -60°C to +125°C.

Decoding of part number

A connector with part number RP-10-7-L-P-T means as follows: -

- RP-IO : Connector type
- 7 : Number of contacts (can be -11, 15, 22, 30, and 42)
- L : With catcher: ('3' with lock nut)
- P : Shell type (straight), U - angle type, B - side type
- T : Tropicalise

Current per connector is given in the table below: -

Number of contacts	Total current per connector (Amp)	Permitted number of contacts carrying 15 Amps of current
7	73.5	3
11	115.5	4
15	135	5
22	165	6
30	180	7
42	220.5	8

1.3.10 CONNECTOR TYPE: RRN

These types of connectors are having threaded connections and their contact material is either aluminum, or chromium or copper.

Specifications

(a) The operating temperature of these type of connector is between -60°C to and 200°C .

(b) Type of wire fitting into contact is by crimping.

(c) Grades of wires tolerable to be fitted into connector is thermo-electrode, type PTFDE-
NM-MT.

d) Specific requirement is to use these connectors ill the thermocouple circuits.

Decoding of part number

A connector with part number R-RN-25M-20-18-SH-2-V-4-X means as follows:-

R	:	Connector
RN	:	Threaded connection
25M	:	Development number
20	:	Number of contacts
18	:	Diagram number
SH	:	Pins (G - sockets)
2	:	Sleeve type
V	:	All climates
4	:	Arbitrary number of contact set
X	:	Contact material, chrome (A - Alum, K - Copper)

1.3.11 Interchangeable Connectors

Russian connectors are interchangeable as recommended in the table below:

Main Variant	Tolerable interchange
2RM...	2RMT...
2RMT.	2RM...
2RMD...	2RMDT
2RMDT.	2RMD

2RM...AL	2RM...B1
	2RMA2
2RM...V1	2RMA1
2RMD...AL	2RMDV1
	2RMDA2
SHR	2RT...
2RMD...V1	2RMD...A1
2RM...A2	No interchange possible
SNTs23	No interchange possible

1.4 MIL STD Connectors

Major MIL-Specifications by Type

1.4.1 Standard, MIL-DTL-5015

- Older larger series of connectors
- Found on many pieces of military equipment and commercial applications
- Mostly heavy current carrying connectors
- Early types had only solder type contacts
- Later revision to MIL Spec also added crimp type contacts
- Several variations of basic MIL-DTL-5015 and MIL-DTL-22992 types are available in the same and additional contact arrangements.
- MIL-DTL-5015 threaded coupling - 1 key/keyway shell polarization

MIL-DTL-5015 Shell Styles	
3100	Wall Mount Receptacle
3101	Cable Connecting Receptacle*
3102	Box Mount Receptacle
3106	Straight Plug
3108	90 ° Plug
3107	Quick Disconnect Plug (97 Series only)

Contact Sizes

Contact Size	16	12	8	4	0
American Wire Gauge Wire Size (AWG)**	16-20	12-14	8-10	4-6	0-2

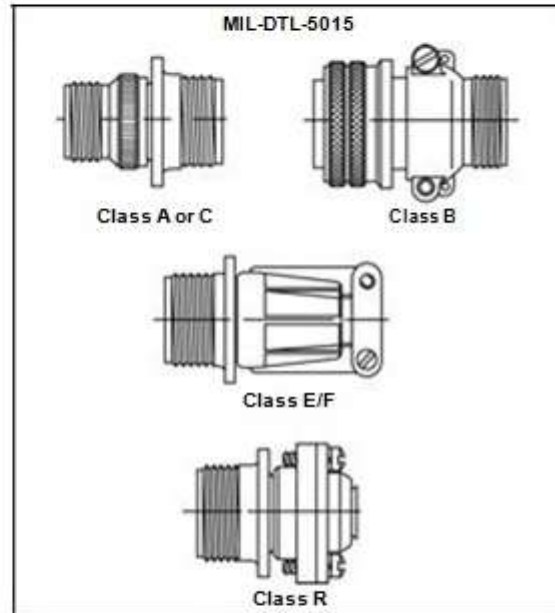
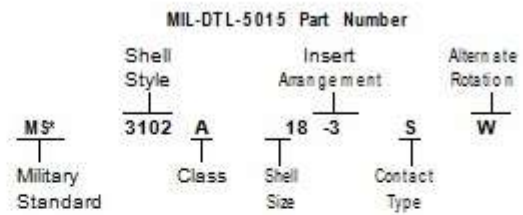

Mating Halves

- Plugs: MS3106, MS3107, MS3108 or
- Receptacles: MS3100, MS3102, MS3101, 97-3101,
- Other Non-MIL-Mates, Flange Mounted
- Flange Mounted Plug: FP3106, 97-5105
- Thru-bulkhead Receptacle: TBF

Alternate Positions of Insert Arrangements

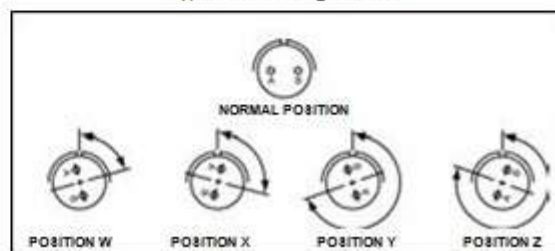

4

1.4.2 Miniature, MIL-DTL-26482

- Widely used smaller connectors
- Extensive use on military equipment including aircraft as well as commercial applications
- Available with either crimp or solder type contacts
- 3 point bayonet coupling
- Popular low cost series
- 5 Key/keyway shell polarization
- MS311X , solder type contacts (Series 1)
- MS312X crimp type contacts (front release) (Series 1)
- MS347X crimp type contacts (rear release) (Series 2)

MIL-DTL-26482 Series 2 is the same as MIL-DTL-83723 Series 1 and will intermate. The Series features rear removable contacts – accessories are ordered separately. MIL-DTL-83723 Series 1 has been superseded by MIL-DTL-26482 Series 2.

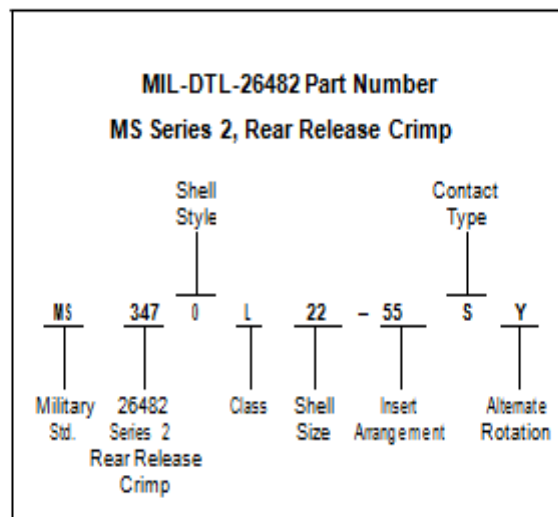
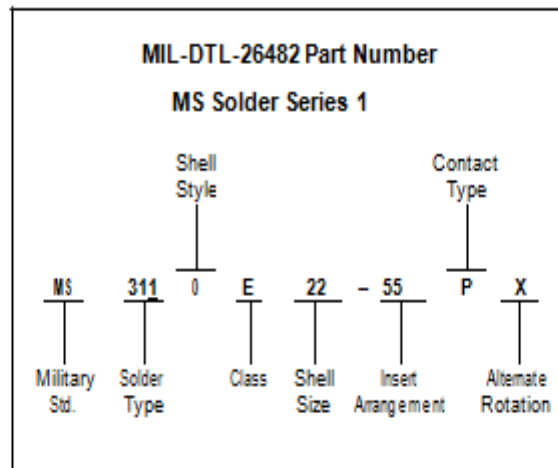
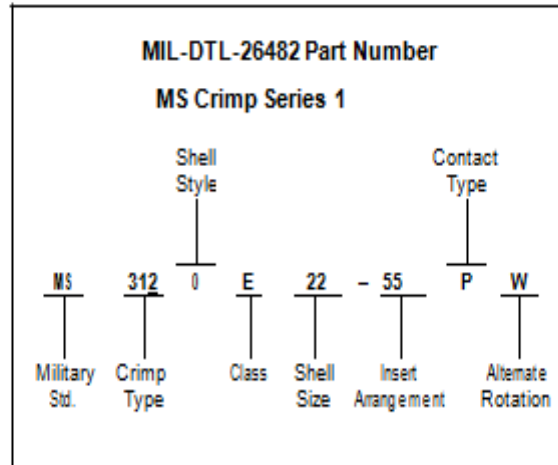

How to Order BY MILITARY PART NUMBER MIL-DTL-26482 Series 2
Connectors

MS 3470 W 12-10 P W
1 2 3 4 5 6 7

1. Connector Type
MS designates Military Standard

2. Connector Style
3470 wall mounting receptacle with narrow flange
3472 wall mounting receptacle with wide flange
3471 cable connecting receptacle
3474 jam nut receptacle
3476 straight plug
3475 straight plug with RFI grounding fingers

3. Service Class
L aluminum shell, electrolyses nickel finish, fluid resistant insert
A aluminum shell, black anodized finish, non-conductive fluid resistant insert
W aluminum shell, olive drab cadmium plated, fluid resistant insert

- 4-5. Shell size and insert arrangement - See chart on page 9 and pattern drawings that follow.

6. Contact Types P designates pin
S designates socket A designates less pins
B designates fewer sockets

7. Insert Rotation

Part Number Nomenclatures for Crimp Connectors to MIL-DTL-26482 Specification

To more easily illustrate ordering procedures, part number MS3120E-20-41PW is broken down as follows:

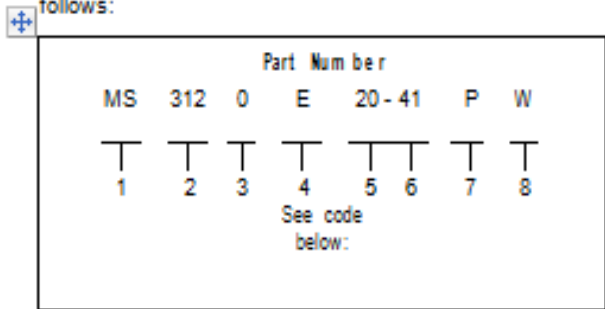

1. "MS" designates Military Standard
2. "312" designates basic family number for MIL-Spec 26482 crimp type
3. Shell Style
 - "0" designates wall mount receptacle
 - "1" designates cable connecting receptacle
 - "2" designates box mount receptacle
 - "4" designates jam nut receptacle
 - "6" designates straight plug
 - "7" designates box mount receptacle with dual mounting holes
 - "8" designates wall mount receptacle with dual mounting holes
4. Service Class
 - "E" designates environmental resisting connector
 - "F" designates environmental resisting connector with strain relief
 - "P" designates potted type with potting boot
5. "20" designates shell size. Shell sizes available are 8 through 24.
6. "20-41" designates insert arrangement
7. "P" designates pin contacts; "S" for socket contacts
8. "W" designates that the insert is rotated in its shell from the standard position to alternate position W. The basic rotations are W, X, Y, and Z. No letter required for normal (no rotation) position.
9. Service

Part Number Nomenclatures for MS Solder Connectors to MIL-DTL-26482 Specification

To more easily illustrate ordering procedures, part number MS3110E20-41PW is shown as follows:

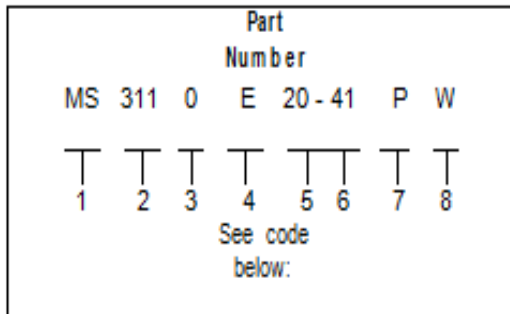

1. "MS" designates Military Standard
2. "311" designates basic family number for MIL-Spec 26482 solder type
3. Shell Style
 - "0" designates wall mount receptacle
 - "1" designates cable connecting receptacle
 - "2" designates box mount receptacle
 - "4" designates jam nut receptacle "6" designates straight plug
4. Service Class
 - "E" designates environmental resisting connector with grom-met and clamping nut
 - "F" designates environmental resisting connector with grom-met and strain relief
 - "J" designates clamp assembly for moisture proofing multi-jacketed cables, with strain relief
 - "P" designates potted type with potting boot
5. "20" designates shell size. Shell sizes available are 8 through 24.
6. "20-41" designates insert arrangement
7. "P" designates pin contacts; "S" for socket contacts
8. "W" designates that the insert is rotated in its shell from the standard position to alternate position W. The basic rotations are W, X, Y, and Z. No letter required for normal (no rotation) position.

Major MIL-Specifications by Type cont

1.4.3 MIL-DTL-38999

Series I

- 100% scoop-proof
- High density arrangements (up to 128 contacts)
- Contact sizes 12 through 22D plus size 16, 12, 8 coax, and size 8 twinax
- Bayonet coupling
- DOD preferred
- Corrosion resistant (500 hr. salt spray) finish available
- Removable crimp, PCB, wire wrap, twinax, and coax contacts available
- Options include Hermetics, Filters and Thermocouples
- 5 key/keyway polarization with 4 alternate keying
- Shell grounding fingers are standard on all plug
- Triple-web grommet seal
- Available in a Fail Safe Lanyard Release plug: see

Series II

- High density arrangements (up to 128 contacts)
- Low silhouette, light-weight non-scoop-proof
- Bayonet coupling
- Contact sizes 12 through 22D plus size 16 & 12 coax
- 5 key/keyway polarization with 4 alternate keyings
- Removable crimp, PCB, wire wrap and coax contacts available
- Corrosion resistant (500 hr. salt spray) finish available
- Options include Hermetics, Filters and Thermocouples
- Shell grounding fingers on plugs are an option
- Triple-web grommet seal
- Available in Fail Safe Lanyard Release plug

|

**Subminiature
Part Number Breakdown Series I**

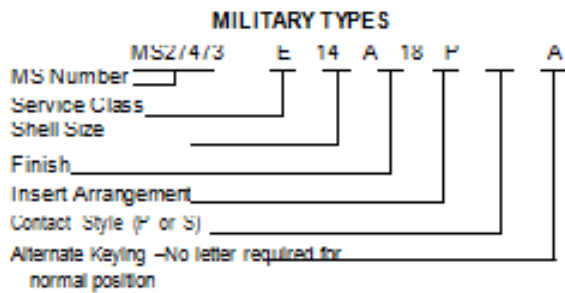

Military Service Class

E Environmental, same as RE I

Environmental, same as RI

Y Hermetically sealed, same as Y P Potting, same as RP

For finish variations see finish data on following page.

P or MS depictions and dimensional data see applicable MIL-Spec. (MIL-U 1L-38999, MIL-U 1L-2/599).

Specifications

CONTACT RATING

Contact Size	Test Current		Maximum Millivolt Drop Crimp*	Maximum Millivolt Drop	
	Solder & Crimp	Hermetic		Solder*	Hermetic*
22M	3	2	45	20	60
22D	5	3	73		85
22	5	3	73	20	85
20	7.5	5	55	20	60
18	13	10	49	20	85
12	23	17	42	20	85
10 Power	33	NA	33	NA	NA

*All tests tested using silver plated wire

Contact Size	Crimp Well Data		Solder Well Data	
	Well Diameter	Normal Well Depth	W Diameter	Normal Well Depth
22M	.028 ± .001	.141	.029 ⁺⁰⁰⁴ ₋₀₀₀	.094
22D	.0345 ± .0010	.141	.034 ⁺⁰⁰⁴ ₋₀₀₀	.094
22	.0365 ± .0010	.141	.036 ⁺⁰⁰⁴ ₋₀₀₀	.094
20	.047 ± .001	.209	.044 ⁺⁰⁰⁴ ₋₀₀₄	.125
18	.067 ± .001	.209	.078 ⁺⁰⁰⁰ ₋₀₀₄	.141
12	.100 ± .002	.209	.116 ⁺⁰⁰⁴ ₋₀₀₂	.141
10 Power	.137 ± .002	.355	NA	NA

SERVICE RATING**

Service Rating	Suggested Operating Voltage (Sea Level)		Test Voltage (Sea Level)	Test Voltage 50,000 Ft.	Test Voltage 70,000 Ft.	Test Voltage 110,000 Ft.
	AC (RMS)	DC				
M	400	500	1300 VRMS	550 VRMS	350 VRMS	200 VRMS
N	300	450	1000 VRMS	400 VRMS	260 VRMS	200 VRMS
I	600	850	1800 VRMS	600 VRMS	400 VRMS	200 VRMS
II	900	1250	2300 VRMS	800 VRMS	500 VRMS	200 VRMS

FINISH DATA

Aluminum Shell Components Non-Hermetic				
Finish	Suffix		Indicated Finish Standard for JT Types Listed Below	Standard for LJT Types Listed Below
	Military	Proprietary		
Cadmium Plated Nickel Base	MS (A)	-	JT/JTG/JTL/JTP	LJT/LJTP
Anodic Coating (Alumilite)	MS (C)	(005)	JTS/JTPS/JTLS	LJTPS/LJTS
Chromate Treated (Iridite 14-2)		(011)	JTN/JTPN/JTLN	LJTN/LJTPN
Olive Drab Cadmium Plate Nickel Base	MS (B)	(014)		
Electroless Nickel	MS (F)	(023)		

Hermetic Connectors				
Material Finish	Suffix		Indicated Finish Standard for JT Types Listed Below	Indicated Finish Standard for LJT Types Listed Below
	Military	Proprietary		
Carbon Steel Shell Tin Plated Shell and Contacts			JT () H/JT () Y JTL () H/JTL () Y	LJT () Y/LJT () H
Carbon Steel Shell Tin Plated Shell and Gold Plated Contacts	MS (D)	(452) special termination (468) solder cup		
Stainless Steel Shell Gold Plated Contacts	MS (E)	(162)	JTS () Y JTLS () Y	LJTS () Y

1.4.4 MIL-DTL-38999, Series III

- 100% scoop-proof
- High density contact arrangements
- Contact sizes 12 through 22D plus size 8, 12, 16 coax, and size 8 twinax
- Removable crimp, PCB, wire wrap, coax, triax, twinax and high speed quadra~~x~~ and differential twinax contacts
- Fiber optics available with MIL-PRF-29504 ferrule, MT ferrule ferrule and ARINC 801 ferrule

- Options include Hermetics, Filters and Thermocouples
- Self-locking, quick disconnect threaded coupling
- Corrosion resistant - shells of stainless steel or cadmium plate over nickel withstand a 500 hour salt spray exposure
- Moisture resistance - Improved interfacial seal design pre-vents electrolytic erosion of contacts
- EMI shielding - designed to obtain metal-to-metal coupling, the TV connector provides a superior EMI shielding capability
- Vibration/Shock - operates under severe, high temperature shock and vibration testing through 200° C
- Clutch-Lok™ MIL-DTL-38999 Series III High Vibration Connector - All advantages of stainless steel/Class K firewall Tri-Start connectors plus a unique clutch design that actually tightens itself under vibration
- Firewall capability - available in stainless steel shell, Class K
- Composite Tri-Start, qualified to MIL-DTL-38999, Rev. J - offers a lightweight, corrosion resistant connector with the same high performance features as its metal counterpart.
 - Lightweight: 17% - 70% weight savings
 - Corrosion resistance: withstands 2000 hrs. of salt spray exposure
 - Durability: 1500 connector couplings
- Locksmith keying - 5 keyway polarization provides 5 alternate rotations
- Shell grounding fingers are standard on all plugs
- Triple-web grommet seal
- DOD preferred
- Available in a Fall Safe Lanyard Release plug

CONTACT RATING

Contact Size	Test Current		Maximum Voltage Drop*	
	Crimp	Hermetic	Crimp**	Hermetic**
22D	5	3	73	85
20	7.5	5	55	60
16	13	10	49	55
12	23	17	42	55
10 (Power)	33	NA	33	NA

* Maximum Voltage Drop data is determined by measuring resistance of mated contacts, from end to end

** When using silver plated wire

Contact Size	Crimp Well Data		Hermetic Well Data	
	Well Diameter	Nominal Well Depth	Well Diameter	Min. Well Depth
22D	.0345 ± .0010	.141	.036 +.004 -.000	.094
20	.047 ± .001	.209	.044 +.004 -.000	.125
16	.067 ± .001	.209	.078 +.004 -.002	.141
12	.100 ± .002	.209	.116 +.004 -.002	.141
10 (Power)	.137 ± .002	.355	NA	NA

FINISH DATA

Non-Hermetic Shell Components		
Finish	Service Class	
	Military	Proprietary
Anodic Coating (Non-Conductive)	C	RX***
Electroless Nickel	F	RF
Olive Drab Cadmium Plate Nickel Base	W	RW
Stainless Steel with Nickel Plate	B	RB
Stainless Steel	K	RK
Olive Drab Cadmium Plate, Composite	J	RJ
Electroless Nickel Plate, Composite	II	RF
Hermetic Connectors		
Material/Finish	Suffix	
	Military	Proprietary
Stainless Steel	Y	Y
Stainless Steel, Nickel Plate	N	YN

1.4.5 Cross Reference by MIL-Spec to Major Manufactures Part Number

**MIL-DTL-5015 (Solder Type)
Typical Part No. - MS310X**

Class	Amphenol		ITT Cannon
	A, C, E, F, R	A, B	A, C, E, F, B, K, R
Proprietary Part No. (A.N.-M.S.)	GP, SC, SF CS, SG, SB SM, ACS	MS310X or 97310X	CA310X
Shell Size:			
MS3100	X	X	X
MS3101	X	X	X
MS3102	X	X	X
MS3103	X	X	X
MS3106	X	X	X
MS3107	see 97 Series	X	X
MS3108	X	X	X

**MIL-DTL-5015 (Crimp - Front Release)
Typical Part No. - MS340X**

Amphenol	S.A.E.	Trans Tech (Flight)	Cannon
DNS*	MOXD, MOKD	FF	WFS

**MIL-DTL-5015 (Crimp - Rear Release)
Typical Part No. - MS3450X**

Amphenol	ITT	S.A.E.	Trans Tech	Aero Electric
944X	CV345X	MSX	MS	AE

**MIL-DTL-26482 (Solder Type) Series 1
Typical Part No. - MS311X**

	Amphenol	Isairis	Cannon	Remstrom	Arco	Veam
Type	PT	BT/BS1	KPT	BR-01	PW	VPT
Shell Style:						
MS3110	X	X	X	X	X	X
MS3111	X	X	X	X	X	X
MS3112	X	X	X	X	X	X
MS3113	X	X	X			X
MS3116	X	X	X	X	X	X
MS3114	X	X	X	X	X	X

**MIL-DTL-26482 (Crimp - Front Release) Series 1
Typical Part No. - MS312X**

	Amphenol	Burndy	Cannon	Arco
Type	PT-8E	LTE, LTF	KP-1E	PWF
Shell Style:				
MS3120	X	X	X	X
MS3121	X	X	X	X
MS3122	X	X	X	X
MS3126	X	X	X	X
MS3124	X	X	X	X
MS3127	X	X	X	
MS3128	X	X	X	

Amphenol Proprietary Internates: DC, SP, BP, also PT-CE.

**MIL-DTL-26482 (Crimp - Rear Release) Series 2
Typical Part No. - MS347X**

Amphenol	Cannon	Deutch	Aero	Corbalr
MB1	PV	AFD	AE	CT097

Intermating Chart

MIL Series	All 6016	All 8411	All 26500	Series I 38999	Series II 38999	Series III 38999	Series I 27599	Series II 27599	Series I 83723	Series II 83723	Series III 83723	Series I & II 81511	Series II & IV 81511
All 5015	X									X			
All 26482*		X							X				
All 26500			X								X		
Series I 38999				X			X						
Series II 38999					X			X					
Series III 38999						X							
Series I 27599				X			X						
Series II 27599					X			X					
Series I 83723		X							X				
Series II 83723	X									X			
Series III 83723			X										
Series I & II 81511												X	X
Series III & IV 81511												X	X

* Except push pull coupling

Cross Reference by MIL-Spec to Major Manufacturers Part No. MIL-DTL-38999 (Crimp Rear Release) Series I, II, III and IV

Series	Amphenol	Amphenol India	Cannon/Vecam	G & H	Deutech	Souriau	American Micro Products
I	LJT		KJL/LTT	-	DJT	8LT	3C&B
II	JT		KJ	-	DJT	8T	XC7C-(-)
III	TV-CTV	ITV	KJA/VTTG3XXX	G-300	DTS	8D	X(-)C-(-)
IV	-		-	BLXX	DIV	-	

Series	Socapex	Amphenol LTD	Aero Electric	Deutech LTD/ Degan
I	LJT	LJT	AE16	DJT
II	-	JT	AE27	DTL
III	TV	TV	AE32	ACT/DTS
IV	-	-	-	-

Series	Herm Seal	Hi-Rel	Sealtron	Glenair
I	9150	7600	A9703	23X
II	9XXX	5X000	A980X	23X
III	HR	8000	A9903	23X
IV	-	-	-	23X

MIL-SPEC Cross Reference Data and General Information

MIL-Spec	Description	Contact Termination & Removal	Contact Sizes in Series (Wire Gauge)	Coupling Method	Other Notes
MIL-DTL-5015	Power type connectors, large contacts Older series had solder contacts; newer has crimp	Solder or crimp, front or rear removal	16 thru 0	Threaded	310X solder, 340X crimp F. R., 345X crimp R. R., GT Series Reverse Bayonet Coupling
MIL-DTL-26482 * Series 1 crimp	Miniature connector. Contacts are medium size, both power and signal currents, solder or crimp	Solder or crimp, front or rear removal	20, 16, 12	Bayonet thread, version Non-Military	311X solder, 312X crimp F. R. 347X crimp R. R.
MIL-DTL-38999	Subminiature - medium and high contact density, crimp contacts. Series I - scoop-proof	Crimp, rear removal	22D, 20, 16, 12, and coax sizes 8, 12, 16	Bayonet	Intermates with Series I of MIL-DTL-27599
	Series II - lightweight, low profile	Crimp, rear removal	22D, 20, 16, 12, and coax sizes 12, 16	Bayonet	Intermates with Series II of MIL-DTL-27599
	Series III - High performance, but suited for general duty	Crimp, rear removal	22D, 20, 16, 12, and coax sizes 8, 12, 16	Threaded	Available in Class K Firewall and Lanyard Release Break-away
	Series IV Breech-Lok, expensive design, can be difficult to mate	Crimp, rear release	22D, 20, 16, 12, and coax sizes 8, 12, 16	Breech-Lok	Does not meet total performance requirements of Series III

*

Intermating Chart

MIL Series	All 5015	All* 3411	All 26500	Series I 38999	Series II 38999	Series III 38999	Series I 27599	Series II 27599	Series I 83723	Series II 83723	Series III 83723	Series I & II 81511	Series II & IV 81511
All 5015	X									X			
All 26482*		X							X				
All 26500			X								X		
Series I 38999				X			X						
Series II 38999					X			X					
Series III 38999						X							
Series I 27599				X			X						
Series II 27599					X			X					
Series I 83723		X							X				
Series II 83723	X									X			
Series III 83723			X										
Series I & II 81511												X	X
Series III & IV 81511												X	X

* Except push pull coupling

Cross Reference by MIL - Spec to Major Manufacturers Part No. MIL-DTL-38999 (Crimp Rear Release) Series I, II, III and IV

Series	Amphenol	Amphenol India	Cannon/Vecam	G & H	Deutech	Souriau	American Micro Products
I	LJT		KJL/LTT	-	DJT	8LT	3C&B
II	JT		KJ	-	DJT	8T	XC7C-()
III	TV-CTV	ITV	KJA/VTTG3XXX	G-300	DTS	8D	X () C-()
IV	-		-	BLXX	DIV	-	

Series	Socapex	Amphenol LTD	Aero Electric	Deutech LTD/ Dagan
I	LJT	LJT	AE16	DJT
II	-	JT	AE27	DTL
III	TV	TV	AE32	ACT/DTS
IV	-	-	-	-

Series	Herm Seal	HI-Rel	Sealtron	Glenair
I	9150	7600	A9703	25X
II	9XXX	5X000	A980X	25X
III	HR	8000	A9903	25X
IV	-	-	-	25X

Qualified Products List by Connector Specification

QPL No./Date	Qualified Product List	Manufacturer
QPL-5015-43 (6/07)	Series I, Solder Type MS3100 Series	Amphenol, ITT Cannon
	Series II, Front Release Crimp MS3400 Series	ElecSys. Inc., J-Tech, TRW Cinch
	Series III, Rear Release Crimp MS3450 Series	Amphenol/Matrix, ITT Cannon, J Tech, Aero Electric, ElecSys. Inc.
	Accessories only*	Glenair, Sunbank, Electro-Adapter, Electro-Sonic Components, Raychem, Triangle Electronics
QPL-26482-100 (4/08)	Series I, Solder MS3110 Series	Amphenol, Array, ITT Cannon, Souriau
	Hermetics only	Amphenol, ITT Cannon, Glasseal, Deutsch, Sealtron, CIA, Herm Seal
	Series I, Crimp MS3120 Series	Amphenol, Burndy, Cannon, Veam, Souriau, Array
	Series II, Hermetic (MS3400) Series	Deutsch, Glasseal, Herm Seal, Array, Sealtron
	Series II, Crimp MS3470 Series	Amphenol, Aero Electric, ITT Cannon, Deutsch, Corsair, Souriau
	Accessories only*	Sunbank, Glenair, Array
QPL-83723-66 (11/06)	Series I	Superseded by and transferred to MIL-DTL-26482 Series II
	Series II	ITT Cannon
	Series III	Amphenol, TRW Cinch, Deutsch, Pyle-National, Aero Electric, ITT Cannon
	Hermetics only	Connector Industries, Herm Seal, Sealtron
	Accessories only*	Glenair, Joslyn Sunbank
QPL-38999 (4/08)	Series I	Amphenol/Pyle, Amphenol Limited, Amphenol Socapex, Souriau, ITT Cannon, Deutsch, Aero Electric, JEC, Hi Rel
	Series II	Amphenol, ITT Cannon, Deutsch, Souriau, Aero Electric, Hi Rel
	Hermetics only	Herm Seal, Sealtron, American Micro Products, Glenair
	Series III	Amphenol, Amphenol Socapex, Amphenol/Pyle, TEC, Deutsch, Souriau, ITT Cannon, Amphenol Limited, Deutsch LTD, Hi Rel, Aero Electric, American Micro Products, Glenair
	Series IV	G & H Technology, Deutsch, Glenair
	Accessories only*	ESC, Joslyn Sunbank
QPL-22992-38 (1/08)	MS17340 Series (QWLD)	Amphenol, ITT Cannon
	Class "L" (MS90555) Series)	Amphenol, General Connector
QPL-27599-14 (12/07)	38999 Solder	Amphenol
QPL-26500-70 (12/05)	Miniature Cylindrical	Amphenol/Pyle, TRW Cinch, Aero Electric, Herm Seal, RMS
	Accessories only*	Glenair, ESC
QPL-81511-9 (12/98)		Amphenol, Deutsch
QPL-AS39029-2 (7/07)	MIL-C-26482 Series 1, Contacts	Amphenol/Pyle, Deutsch, ITT Cannon, Tri-Star, Cinch, Veam
	MIL-C-26482 Series 2, Contacts	Amphenol/Pyle, Deutsch, ITT Cannon, Tri-Star, NCMI
	MIL-DTL-38999, Contacts	Amphenol/Pyle, ITT Cannon, Tri-Star, AMP, General Connector
	MIL-C-22992, Class "L", Contacts	Amphenol, General Connector
	Other Contacts	May include all of the above, plus: Continental Connector, AMP, J Tech. Precision Technology, Winchester and others

Chapter-II

Performance Requirements for Connectors (MIL-DTL-83527B)

2.1 Performance Requirements: Connectors, inserts, shells, backshells, contacts, and accessories shall be designed to meet the performance requirements specified herein when tested in accordance with the specified methods.

Examination of product: Contacts, inserts, shells, backshells, connectors, and accessories shall be examined as specified and shall meet the requirements indicated herein.

Nonmagnetic materials: The relative permeability of the wired assembled, and fully mated connector assembly shall be less than 2.0 when measured.

Mating and separating forces: When tested the maximum force needed to mate or separate counterpart plugs and receptacles shall not exceed 1446 newtons (325 lbf) for size 2, 1780 newtons (400 lbf) for size 3, and 2113 newtons (475 lbf) for size 4.

Maintenance aging, contact insertion and removal forces: After testing as specified, connectors shall be capable of meeting the performance requirements of this specification. After testing, the individual contact insertion and removal forces shall not exceed the values listed in table III below. Failure to complete these operations shall be cause for rejection.

TABLE III. Insertion and removal forces.

Contact size <u>1/</u>	Axial loads (newtons)	
	Insertion	Removal
22	45	36
20	67	45
16	90	67
12	112	90
8 Concentric twinax	135	112
Size 5 coaxial	135	112

Contact retention: When tested, the axial displacement of the contacts shall not exceed 0.3 mm. No dislodging or damage to contacts or inserts shall result.

Thermal shock (temperature cycling): When tested, connectors shall meet the performance requirements of the remaining test sequence. There shall be no damage detrimental to the operation of the connectors.

Insert retention: When tested, connectors shall retain their inserts in their proper location in the shell. The maximum axial displacement allowed shall be 0.25 mm. Evidence of cracking, breaking, separation from the shell, or loosening shall be cause for rejection of parts.

Salt spray (corrosion): After testing, unmated connectors and individual contact samples shall show no exposure of basic metal (due to corrosion), which will adversely affect performance.

Contact resistance: The contact resistance shall be in accordance with the applicable specification sheet of MIL-C-39029 and shall be tested.

Insulation resistance at ambient temperature: When tested, the insulation resistance between any pair of contacts and between any contact and the shell shall be greater than 1,000 megohms.

Insulation resistance at elevated temperature: When tested, the insulation resistance between any pair of contacts and between any contact and the shell shall be greater than 1,000 megohms.

Withstanding voltage. When tested, connectors shall show no evidence of flashover or breakdown.

Durability. When tested, the connector shall show no defects detrimental to the operation of the connectors and shall meet the subsequent test requirements.

Vibration. When tested, a current discontinuity of 1 microsecond or more, evidence of cracking, breaking, or loosening of parts shall be cause for rejection. Damaged fixtures or tie downs may be repaired or replaced to complete the test.

Shock: When tested, a current discontinuity of 1 microsecond more shall be cause for rejection. Evidence of cracking, breaking, or loosening of parts shall be cause for rejection. Damaged fixtures or tie downs may be repaired or replaced to complete the test.

Static load: When tested, during and after the application of the specified forces, connectors shall show no evidence of damage detrimental to their normal operation nor shall there be any interruption of electrical continuity. The connectors shall withstand a compressive load of 10888 newtons (2450 lbf), a vertical load of 5115 newtons (1150 lbf), and a side load of 2265 newtons (509 lbf).

Shell-to-shell and shell-to-bulkhead resistance: When tested, plugs and receptacles shall be electrically conductive. The maximum potential voltage between the shells of the connector pair shall not exceed 2.5 millivolts.

Humidity: When tested, the insulation resistance shall be 100 megaohms or greater. Connectors shall show no deterioration or damage that will adversely affect performance.

EMI shielding: When tested, the EMI shielding capabilities of mated shells shall not be less than that specified in table IV below at the specified frequencies.

TABLE IV. Shielding effectiveness.

Frequency (MHz)	Leakage attenuation (dB)	Frequency (MHz)	Leakage attenuation (dB)
100	65	400	62
200	63	800	60
300	63	1,000	60

Ozone exposure: When tested, the connectors shall show no evidence of cracking of dielectric material, deterioration of resilient seals, or other damage due to ozone exposure that will adversely affect performance.

Fluid immersion: After immersion in the fluids, connectors shall unmate and mate properly and resilient materials shall show evidence of material reversion. Shells, plating, and dielectric materials shall show no evidence of deterioration, distortion, or material reversion.

Altitude immersion: When tested, the mated connector shall meet the requirements of dielectric withstanding voltage.

Contact walkout: When tested as specified, contacts shall not become dislodged from their normal position.

Installing and removal tool abuse. When tested, there shall be no evidence of damage to the contacts, the connector inserts, or the contact retaining mechanism.

Contact stability (sizes 22, 20, 16, and 12 crimp contacts): When tested in accordance with the total displacement of the contact tip end shall not exceed 0.25 mm for the size 22 socket contact, 1.0 mm for the size 20 pin contact, and 1.5 mm for the size 16 and size 12 pin contact.

Temperature life with contact loading: When subjected to the test, the contacts shall maintain their previously measured location with not more that 0.3 mm change.

Size 8 concentric twinax cavity grounding: When tested, the maximum potential drop between the size 8 concentric twinax outer body and the connector mounting flange shall not exceed 10.0 mV.

Interchangeability: The connector plugs, receptacles, inserts, contacts, and accessories supplied to the specification shall meet the requirements of the applicable specification sheet and shall be completely interchangeable with the components having the same part or identifying numbers (PIN) but supplied by another qualified connector manufacturer.

2.2 Marking:

Connectors and accessories: Connectors and accessories shall be marked in accordance with method 1 of MIL-STD-1285, and shall include the military part or identifying number the manufacturer's name or code symbol, Manufacturer's Commercial and Government Entity (CAGE), and data code. The characters shall be a minimum of 1.5 millimeters in height. If used, metal stamping shall be accomplished before plating. Connector shell marking and insert marking shall remain legible after completion of the tests.

Insert identification: The military Part or Identifying Number (PIN), manufacturer's identification, Manufacturer's Commercial and Government Entity (CAGE), and date code shall appear on the side of the insert in a contrasting color.

Contact designation: Contact locations shall be designated with identifiable characters as indicated on the applicable specification sheet. All positions shall be identified on the front and rear faces of the insert except where space limitations make this impracticable. Location of contact identifying characters shall be in close proximity to the holes but need not be placed exactly where indicated on the standard. Inserts containing size 22 contacts shall be marked with a 5 by 5 grid pattern rear face in accordance with DOD-STD-1842.

Workmanship: The connector shall be fabricated in a manner such that the criteria for appearance, fit, and adherence to specified tolerances are observed. Particular attention shall be given to neatness and thoroughness of marking parts. Plating, welding, soldering, riveting, staking, bonding, and parts shall be free of burrs and sharp edges.

2.3 VERIFICATION

Classification of inspections: The inspections requirements specified herein are classified as follows:

- a. First article inspection.
- b. Conformance inspection.

First article inspection: First article inspection shall consist of materials inspection; all the tests in table V below as applicable to the contact or purchase order, and examinations of this specification.

2.4 Conformance inspection

Inspection of product for delivery. Inspection of product for delivery shall consist of group A inspection.

Inspection lot: An inspection lot shall consist of all connectors covered by one specification sheet, produced under essentially the same condition, and offered for inspection at one time.

MIL-DTL-83527B

TABLE V. First article inspection test sequence.

Test	Group						Requirements paragraph	Test method paragraph
	I	II	III	IV	V	VI		
Examination of product	X	X	X	X	X	X	3.5.1	4.6.1
Contact location	X						3.4.4.2	4.6.3
Nonmagnetic materials	X	X	X				3.5.2	4.6.27
Size 8 cavity grounding	X						3.5.27	4.6.28
Insulation resistance, (ambient temperature)	X	X					3.5.10	4.6.11.1
Insulation resistance, (elevated temperature)	X	X					3.5.11	4.6.11.2
Withstanding voltage, (sea and altitude)	X	X					3.5.12	4.6.12.1 and 4.6.12.2
Mating and separating forces	X	X	X				3.5.3	4.6.4
Maintenance aging, (contact insertion and removal forces)				X			3.5.4	4.6.5
Thermal shock	X	X			X		3.5.6	4.6.7
Withstanding voltage, (sea level)	X	X					3.5.12	4.6.12.1
Humidity		X					3.5.18	4.6.18
Insulation resistance, (ambient temperature)		X					3.5.10	4.6.11.1
Insulation resistance, (elevated temperature)		X					3.5.11	4.6.11.2
Vibration (functional and endurance)	X <u>1/</u>			X <u>2/</u>			3.5.14	4.6.14.1 and 4.6.14.2
Static load			X				3.5.16	4.6.16
Shock <u>3/</u>	X						3.5.15	4.6.15
Durability	X						3.5.13	4.6.13
Insulation resistance, (ambient temperature)			X				3.5.10	4.6.11.1
Withstanding voltage, (sea level)			X			X	3.5.12	4.6.12.1
Altitude immersion			X				3.5.22	4.6.23
Salt spray (corrosion)			X <u>4/</u>	X <u>5/</u>			3.5.8	4.6.9.1 and 4.6.9.2
Contact resistance	X	X					3.5.9	4.6.10
Insulation resistance, (ambient temperature)	X						3.5.10	4.6.11.1
Insulation resistance, (elevated temperature)	X						3.5.11	4.6.11.2
Withstanding voltage, (sea level)	X						3.5.12	4.6.12.1
Shell-to-shell and shell-to-bulkhead resistance					X		3.5.17	4.6.17
EMI shielding					X		3.5.19	4.6.19
Contact walkout (one connector)			X				3.5.23	4.6.22
Ozone exposure	X						3.5.20	4.6.20
Installing and removal tool abuse						X	3.5.24	4.6.24
Contact stability		X					3.5.25	4.6.25
Temperature life with Contact loading			X				3.5.26	4.6.26
Fluid immersion <u>4/</u>	X	X	X	X			3.5.21	4.6.21
Contact retention	X	X	X	X			3.5.5	4.6.6
Insert retention	X	X	X	X			3.5.7	4.6.8
Examination of product	X	X	X	X	X		3.5.1	4.6.1

Group A inspection: Each connector shall be subjected to the individual test shown in table VI below. For group A inspection, the documentation and standard test conditions of EIA 364, do not apply.

TABLE VI. Group A inspection.

Group A inspection	Individual test
Visual examination Inspection in accordance with 4.6.1	100 percent
Insulation resistance (ambient temperature) Produced in accordance with 4.6.11.1 <u>1/</u> <u>2/</u>	100 percent
Withstanding voltage (seal level) Produced in accordance with 4.6.12.1 <u>1/</u>	100 percent

1/ The manufacturer may use in-process controls for this requirement.

2/ Test between two adjacent contacts and between two peripheral contacts and the shell.

Visual examination: Each connector shall be visually examined for completeness, workmanship, and identification requirements. Attention shall be given to those assemblies that require a seal to determine the condition of that seal. Seals missing, twisted, buckled, kinked, or damaged in a manner affecting functional performance shall be cause for rejection.

Testing and inspections

Test equipment and inspection facilities: Test and measuring equipment and inspection facilities of sufficient accuracy, quality, and quantity to maintained by the contractor. The establishment and maintenance of a calibration system to control the accuracy of the measuring and test equipment shall be in accordance with ANSI-Z540.1. Testing and inspections shall be performed at a laboratory acceptable to the Government.

Hydrolytic stability: Certification of hydrolytic stability is required, specify material tested and water absorption report as specified in ASTM D570.

Fungus resistance certification: Certification that materials used are fungus inert is required.

Inspection conditions: Unless otherwise specified, all inspections shall be performed in accordance with the test conditions specified in the “General requirements” of EIA-364 and MIL-STD-202.

Sample size: A minimum of 14 plugs and receptacles shall be subjected to the examinations and tests in table V above, in the sequence shown.

Test groups I, and II, III and IV: Each test group shall consist of a minimum of three completely assembled plugs and receptacles representing the class (1.2.1), shell size, and each of the insert arrangements (DOD-STD-1842) for which first article inspection is desired.

Test group V: Sample shall consist of a modified size 2 shell, plug and receptacle.

Test group VI: Test group VI shall consist of a completely assembled mated pair of a plug and receptacle connector using a shell size 2A.

Preparation of samples: Unless otherwise specified, for signal-power contacts (size 22, 20, 16, and 12), half the number of each contact size in each connector shall be wired with the largest allowable AWG size using MIL-W-22759/43 wires. The remaining number of contacts shall be wired with the smallest allowable AWG size using MIL-W-22759/33 or MIL-W-22759/43 wires. Samples of group VI, altitude immersion, may exclude AWG 24 and 26 wires. For shielded contacts and concentric twinax contacts, use applicable cables in accordance with MIL-C-17. Termination tools shall be in accordance with appendix A in the Spec MIL-DTL-83527B.

Qualification of contacts: If a manufacturer submits first article samples of MIL-DTL-83527 connectors, contacts supplied with the samples shall be either qualified to MIL-C-39029 or contacts that have been deemed acceptable by the procuring activity.

Failures: Any failure shall be cause for refusal to grant compliance to first article inspection.

Appendix – E

List of Type Approvals

Appendix – E
List of Type Approvals

1.	Type Approval No.	:	17
2.	Approval Title	:	Terminal Block 2-way Part No. 5CZ-430 (IND)
3.	Validity of Approval	:	27 Oct 1971
4.	Developer of the Item	:	M/s Allied Electronics Corporation, Bombay
5.	Governing Specification	:	BS G 197 (Jan 1961)
6.	Characteristics of Connector		
	a) Classification	:	-
	b) Dielectric Withstanding voltage	:	2000 V (AC rms), 50 c/s for 5 secs
	c) Insulation Resistance	:	> 100 M Ω between studs > 200 M Ω between stud and earth
	d) Temperature Range	:	-40°C to +70°C
7.	End Use of the Item	:	Aircraft Use

1.	Type Approval No.	:	272
2.	Approval Title	:	a) Quick Release Terminals b) Copper Ring Tongue Terminals c) Insulated Inline Connector
3.	Validity of Approval	:	04 Jun 1991
4.	Developer of the Item	:	M/s. Dowell's Elektro Werke, Bombay
5.	Governing Specification	:	As per Drawings Dowell's Cat No. 8013 for QRT Cat No. 7444, 7445, 7595, 7596, 7600, 8052 for CTT Cat No. EH 462 for IIC
6.	Characteristics of Connector		
	a) Classification	:	-
	b) Dielectric Withstanding voltage	:	1500 V (AC rms), 50 c/s
	c) Conductor	:	Electrolytic Grade Copper duly Silver Plated for QRT Electrolytic Grade Copper duly electro-tinned for CTT & IIC
	d) Insulation	:	Insulated with Metal Reinforcement
	e) Temperature Range	:	+ 121°C
7.	End Use of the Item	:	For termination of electric cables and wires in any aircrafts, avionic Instruments and ground equipments electric circuits.
8.	Other Details	:	<ul style="list-style-type: none"> • Quick Release Lock hook Terminal • Copper Ring Tongue Terminal (1.5 sq.mm i.e 16-22 AWG) • Insulated inline connector (1.5 sq.mm)

1.	Type Approval No.	:	284
2.	Approval Title	:	Terminal Blocks 3 ways, 5 ways, 10 ways and 20 ways
3.	Validity of Approval	:	15 Jul 1988
4.	Developer of the Item	:	M/s. KM Bakelite Industries Ltd., Bombay - 400068
5.	Governing Specification	:	a) HAL (BC) Drawing Nos. b) M 10173, Issue A c) M 10360, Issue A d) M 10174, Issue 'A' e) M 10175, Issue 'A' All dated 20 Oct 1975
6.	Characteristics of Connector		
	a) Classification	:	-
	b) Dielectric Withstanding voltage	:	2 kV (AC rms), 50 c/s for one minute
	c) Insulation Resistance	:	> 1000 M Ω at room temperature
	d) Temperature Range	:	-65°C to +105°C
7.	End Use of the Item	:	Electrical Systems of Aircraft

1.	Type Approval No.	:	329
2.	Approval Title	:	Connector type 2PM42 30-pin Connector
3.	Validity of Approval	:	21 Oct 1991
4.	Developer of the Item	:	M/s. Allied Electronics Corporation, Bombay - 400002
5.	Governing Specification	:	a) JSS-50500 b) JSS-50803
6.	Characteristics of Connector		
	a) Classification	:	-
	b) Dielectric Withstanding voltage	:	2000 V AC, 50 c/s for one minute
	c) Insulation Resistance	:	> 100 M Ω at room temperature
	d) Conductor	:	Brass
	e) Insulation	:	Glass filled Phenolic
	f) Temperature Range	:	-55°C to +115°C
7.	End Use of the Item	:	Used in Reusable Rocket Pod
8.	Other Details	:	It is a 30 Pin connector Suitable as a substitute for USSR Grade 2PM42 Connector

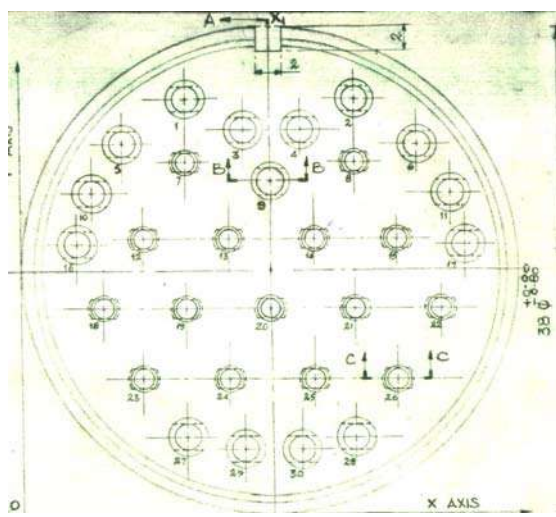

1.	Type Approval No.	:	343
2.	Approval Title	:	Plug connector WP-55 Type-30 Pin (Drg. No. RP-288)
3.	Validity of Approval	:	21 Apr 1984
4.	Developer of the Item	:	M/s. HITECH (India) Pvt. Ltd., Hyderabad - 500762
5.	Governing Specification	:	a) JSS 50812 b) No. TS/IND/91/03, Issue-I
6.	Characteristics of Connector		
	a) Classification	:	-
	b) Dielectric Withstanding voltage	:	2000 V (AC rms), 50c/s for one minute
	c) Insulation resistance between neighboring contacts or body & any contact	:	> 100M Ω under normal condition
	d) Conductor / Pin	:	Brass
	e) Insulation	:	Glass filled Phenolic Bakelite (Cable Insulator)
	f) Temperature Range	:	-55°C to +115°C
7.	End Use of the Item	:	Used as a Plug Connector on aircraft
8.	Other Details	:	Suitable as a substitute for USSR Grade Plug Connector WP55 π 30 H \sqcup 2

1.	Type Approval No.	:	725
2.	Approval Title	:	In Line Data bus coupler Type CP 3001 and CP 3002
3.	Validity of Approval	:	30 Jun 2013
4.	Developer of the Item	:	M/s. Compu Power Private Limited Hyderabad – 500 482
5.	Governing Specification	:	a) No. 3000 - TS b) TS Doc. No. 3001-02 TS c) SAE Doc. AS4117 d) MIL-STD-1553B Data Bus
6.	Characteristics of Connector		
	a) Classification	:	MIL-1553B bus couplers
	b) Dielectric Withstanding voltage	:	600 V (AC rms), 50c/s for one minute
	c) Common Mode Rejection	:	> 45dB
	d) Turns Ratio	:	1.41 ± 3%
	e) Insulation Resistance	:	>100 MΩ
	f) Coupler bus voltage	:	Vout / Vin = 0.331 to 0.374
	g) Open Circuit Impedance	:	3000 Ω from 75KHz to 1MHz
	h) Temperature Range	:	-55°C to +85°C
7.	End Use of the Item	:	For use in Light Combat Aircraft

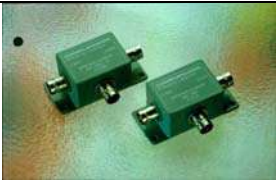
1.	Type Approval No.	:	811	
2.	Approval Title	:	Connectorised Data Bus Coupler Type DBC-2001 & DBC-2001TR	
3.	Validity of Approval	:	31 Dec 2013	
4.	Developer of the Item	:	M/s. Compu Power Private Limited Hyderabad – 500 482	
5.	Governing Specification	:	a) No. A/C M(DL) a/ ID-E/ DLC/TSP/01 dated 17 Aug 1995, b) SAE Doc. AS4117 c) QTP 2001-07, Rev.'A' and d) MIL-STD-1553B Data Bus	
6.	Characteristics of Connector			
	a) Classification	:	MIL-1553B bus couplers	
	b) Weight	:	< 70gms	
	c) Dielectric Withstanding voltage	:	600 V (AC rms), 50Hz for one minute	
	d) Common Mode Rejection	:	> 45dB	
	e) Turns Ratio	:	1.41 ± 3%	
	f) Insulation Resistance	:	>100 MΩ Signal lead to Shield >1000Ω Bus to Stub	
	g) Coupler bus voltage	:	Vout / Vin = 0.331 to 0.374	
	h) Open Circuit Impedance	:	3000 Ω from 75 KHz to 1MHz	
	i) Temperature Range	:	-55°C to +71°C	
7.	End Use of the Item	:	For use in Jaguar Aircraft	

1.	Type Approval No.	:	1051	
2.	Approval Title	:	Connectorised Data Bus Coupler Type DBC-1002 & DBC-1004	
3.	Validity of Approval	:	31 Dec 2018	
4.	Developer of the Item	:	M/s. Compu Power Private Limited Hyderabad – 500 482	
5.	Governing Specification	:	a) Doc. No. 1000-90, Rev 'A' dated 12 May 1998 b) SAE Ref. AS4117 and c) MIL-STD-1553B	
6.	Characteristics of Connector			
	a) Classification	:	MIL-1553B bus couplers	
	b) Dielectric Withstanding voltage	:	600 V (AC rms), 50Hz	
	c) Common Mode Rejection	:	> 45dB	
	d) Turns Ratio	:	1.41 ± 3%	
	e) Insulation Resistance	:	>1000Ω for both Signal lead to Shield & Bus to Stub	
	f) Coupler bus voltage	:	Vout / Vin = 0.331 to 0.374	
	g) Open Circuit Impedance	:	3000 Ω from 75 KHz to 1MHz	
	h) Temperature Range	:	-55°C to +85°C	
7.	End Use of the Item	:	These units provide data bus interface by isolating the main bus from the LRUs by way of transformer coupling for MIL-STD-1553B application for both ground and airborne use.	



1.	Type Approval No.	:	1078	
2.	Approval Title	:	Two Pin Connector (Pocket) Part No. M20181	
3.	Validity of Approval	:	31 Dec 2014	
4.	Developer of the Item	:	M/s. M.E.C Engineers, Bangalore – 560 032	
5.	Governing Specification	:	Test Spec Nos. a) A/DGM(DL)/309/240/00 b) A/DGM(DL)/309/131/2000 dated 21 Feb 2000	
6.	Characteristics of Connector			
	a) Classification	:	-	
	b) Operating Voltage	:	30 V DC	
	c) Contact rating	:	5 Amps	
	d) Millivolt drop at rated current		< 50mv at room temperature	
	e) Dielectric Withstanding Voltage	:	1.5kV AC for 30 secs	
	f) Insulation Resistance	:	> 1000 M Ω at room temperature	
	g) Conductor/ Pin	:	Brass rod	
	h) Connector Body	:	Mould from IPCL polythene granules	
	i) Temperature Range	:	-40°C to +85°C	
7.	End Use of the Item	:	Used in Kiran Aircraft Pylons and Drop Tanks	

1.	Type Approval No.	:	1086	
2.	Approval Title	:	Igniter Connector Assembly – Part No. N377-6600-02	
3.	Validity of Approval	:	30 Jun 2016	
4.	Developer of the Item	:	M/s. M.E.C Engineers, Bangalore – 560 032	
5.	Governing Specification	:	TS/IND/66/01 (Issue-2) dated 20 Jan 2004	
6.	Characteristics of Connector			
	a) Classification	:	-	
	b) Supply Voltage	:	27 ± 10% V	
	c) Current Rating	:	2.5 A	
	d) Dielectric Withstanding Voltage	:	500V AC, 50c/s for one minute	
	e) Insulation Resistance between contact & body	:	> 20 M Ω	
	f) Conductor/contact	:	Steel 20	
	g) Pin	:	Spring Wire II-A	
	h) Temperature Range	:	-60°C to +60°C	
7.	End Use of the Item	:	It is meant for holding the electric supply cable that provides electrical input for the explosion of the Pyro-cartridge PP-3 mounted in Bonnet Head 20S2MIS of fire extinguishing bottle of MiG-21 aircraft variants	
8.	Other Details	:	Assembly is similar to Original Russian assembly GZS.5S	

1.	Type Approval No.	:	1790
2.	Approval Title	:	Connectors- 3 Series, 1) A-2RM, 2) A-2RMD & 3) A-2RMDT
3.	Validity of Approval	:	30 Jun 2018
4.	Developer of the Item	:	M/s. Amphenol Interconnect India Private Limited', 67, Keonics Electronic City, Hosur Road, Bengaluru - 560 100
5.	Governing Specification	:	No. TS/IND/91/03, Issue-4, Dated: 18 Jul 1994 and Amendment No. AML-5, Issue-4, Dated: 09 Feb 2010
6.	Characteristics of Connector		
	a) Classification	:	-
	b) Insulation Strength	:	2000 Volts, 50c/s
	c) Contact Resistance	:	< 0.0025Ω for contact dia 1.5mm
	d) Insulation Resistance between neighboring contacts or between body & any contacts	:	> 100MΩ
	e) Conductor	:	-
	f) Insulation	:	-
	g) Temperature Range	:	-55°C to +115°C (Note: Temperature +125 ±5°C for Silver Plated and 200±10°C for Gold Plated Connectors of family 2RMDT)
7.	End Use of the Item	:	Used for operations at frequency up to 3MHz within the temperature range from -55°C to +115°C and fitted on looms of MiG series and Su-30MKI aircraft.

Appendix– F

List of Connector Manufacturers

SI No.	Manufacturer & address	Contact Details
1.	M/s Dowell's Electro Werke Off Aarey Road Goregaon East BOMBAY – 400 063	Phone: 695381, 695382 Telex: 011-3002 Gram: Dowell's, Bombay - 62
2.	M/s KM Bakelite Industries Anuj Plastic Industrial Estate 121-122 SV Road Dhahisar BOMBAY – 400 068	-
3.	M/s Allied Electronics Corporation 94 Kansara Chawl Kalbadevi Road BOMBAY – 400 002	Phone: 36 52 94 / 35 75 70 Gram: BAKULBAUGH, BOMBAY TELEX: 011/3897 AECO IN
4.	M/s Hitech (India) Private Limited A-11 Electronic Complex ECIL Post, Kushaiguda HYDERABAD – 500 762	-
5.	M/s Compu Power Pvt Ltd., 8-2-350/2/B Road No.03 Banjara Hills HYDERABAD – 500 034	Phone: 91-40-23354583 Tel/Fax: 91-40-23352538 Fax: 91-40-23394654 E mail: compupowerindia@yahoo.com , jagadish@hd1.vsnl.net.in
6.	M/s Compu Power Pvt Ltd., F-16, Sri Sai Apartments 6-3-596/21/8&9 Erramazil HYDERABAD – 500 482	Phone: 91-40-3354583 91-40-3399990 Fax: 91-40-3394654 E mail: jagadish@hd1.vsnl.net.in
7.	M/s MEC Engineers 23, Brindavan Layout Kaval Byrasandra BANGALORE – 560 032	Phone: 3332073 Fax: 26369050 E mail: mecengrs_1987@rediffmail.com
8.	M/s. Amphenol Interconnect India Private Limited', 67, Keonics Electronic City, Hosur Road, Bengaluru - 560 100	Tel: + 91 80 2852 0178 Fax: + 01 80 2852 0418

