

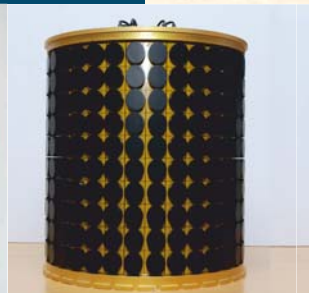

# DRDO

## Products for Export







# DRDO

Products for Export







राजनाथ सिंह  
RAJNATH SINGH



रक्षा मंत्री  
भारत  
DEFENCE MINISTER  
INDIA



## **MESSAGE**

DRDO has emerged as a strong Defence R&D hub with proven competence to develop wide range of defence technologies. Many indigenously developed systems are inducted into Indian Armed Forces, after extensive field evaluation. In the process, these systems attain bench marks of international standards and, therefore, become potential systems for export.

Export of indigenously developed international standard Defence products provides economic, security and political advantage to a country. In order to articulate the emerging geopolitical compulsions, more and more Nations are utilising "Defence Diplomacy" as a strategic tool.

Concurrent to the recent challenges in global economy and geopolitics, India has taken those necessary steps towards converting itself from the world's largest defence importer to the exporter of indigenously developed Defence products. Now, DRDO developed Defence products have created an interest from several Nations and have been exported too.

I congratulate DRDO for taking this proactive step in formulating the compendium on "DRDO Products for Export". This will go a long way in promoting 'Self Reliance' in Defence System and necessary impetus to the industrial infrastructure for enhanced growth.

Jai Hind.

Date: 3 February, 2021  
Place: New Delhi

  
(Rajnath Singh)





सत्यमेव जयते

श्रीपाद नाईक  
SHRIPAD NAIK

राज्य मंत्री (स्वतंत्र प्रभार)  
आयुर्वेद, योग व प्राकृतिक चिकित्सा, यूनानी, सिद्ध,  
सोवा-रिग्पा एवं होम्योपैथी-(आयुष) मंत्रालय एवं रक्षा राज्य मंत्री  
भारत सरकार  
MINISTER OF STATE (INDEPENDENT CHARGE) FOR  
AYURVEDA, YOGA & NATUROPATHY, UNANI, SIDDHA,  
SOWA-RIGPA, HOMOEOPATHY-(AYUSH) &  
MINISTER OF STATE FOR DEFENCE  
GOVERNMENT OF INDIA



## MESSAGE

Defence Exports is accelerating in India. The indigenous technologies play an important role in it. The export will further facilitate the objective of Govt of India of achieving higher growth rate.

While MoD has streamlined the procedure for exports, DRDO has provided the right impetus at right time, in form of the compendium on "DRDO Products for Export".

This compendium provides handy information to our industries to venture out and discuss the export opportunities with the customer countries. I urge that more industries to come forward and take advantage of years of hard work of DRDO and its partner industries to convert it to export worthy products.

I congratulate DRDO for taking this initiative of collating the information on "DRDO Products for Export". This in the long run will enable to achieve higher growth in manufacturing sector that will translate into creation of many opportunities and bringing in great economic benefit to the Nation.

Jai Hind.

(Shripad Naik)

Date: 3 February, 2021  
Place: New Delhi



**डॉ जी. सतीश रेड्डी**  
**Dr G. Satheesh Reddy**  
FNAE, HFCSI, FRIN (London), FMACANUD (Russia), FAeSI, FRAeS (UK),  
HFPMIAI, FSSWR, FIET (UK), FIE, FAPAS, FIETE, AFAJAA (USA)



सत्यमेव जयते  
भारत सरकार  
Government of India



सचिव, रक्षा अनुसंधान तथा विकास विभाग  
एवं  
अध्यक्ष, डीआरडीओ  
Secretary, Department of Defence R&D  
&  
Chairman, DRDO



## **MESSAGE**

DRDO has designed & developed systems of complex technologies, configured and adapted to the Indian scenario. However, it is capable of customising the systems to address varied requirements in interface, interoperability and service requirements as needed by a User. Some of the products developed by DRDO are being exported through industry. There is a constant demand for DRDO developed products from many countries.

During various meetings and exhibitions, many friendly countries have shown an interest in acquiring DRDO developed systems. In spite of the present order of world economy and challenges being faced, Indian industries are capable to produce quality defence systems for export, which would help in establishing and nurturing a longterm relationships with friendly countries along with strengthening their Defence Forces and Homeland Security.

I congratulate all DRDO personnel for their efforts in preparing the Compendium of "DRDO products for Exports" to pave the way for enhanced defence exports by India.

Jai Hind.

Date: 3 February, 2021  
Place: New Delhi

Dr G Satheesh Reddy





जी एन राव  
उत्कृष्ट वैज्ञानिक  
एवं  
महानिदेशक (पी सी एवं एस आई)

**G N Rao**  
OUTSTANDING SCIENTIST  
&  
DIRECTOR GENERAL (PC & SI)



रक्षा मंत्रालय  
MINISTRY OF DEFENCE  
रक्षा अनुसंधान तथा विकास संगठन  
DEFENCE RESEARCH & DEVELOPMENT ORGANISATION



## **MESSAGE**

DRDO has developed many technologies which have been converted to systems/products for the tri services. These systems have been productionised through DPSU's OF's & PSUs with the support of more than 1800 industries (mostly from SME sector).

Off late there has been a growing interest in different parts of the world on the products and technologies developed in the country as seen at various expos in & outside the country. It is time to project our products in international markets in an integrated manner. In order to sustain in global competitive market it is imperative that industries to become quality & cost competitive.

The present pro export ecosystem has created an environment for Indian industries to venture out and establish the brand India globally. DRDO is extending all support required by the industries to become the exporter of indigenous defence products. The compendium of "DRDO Products for Export" is a welcome step to support industries for export.

I congratulate 'Team DRDO' for their efforts in evolving the Compendium of "DRDO Products for Export".

Jai Hind.

(G N Rao)

Date: 3 February, 2021

Place: New Delhi



डा मयंक द्विवेदी, एनडीसी

वैज्ञानिक 'जी'

निदेशक

उद्योग संपर्क एवं प्रौद्योगिकी प्रबंधन निदेशालय

**Dr Mayank Dwivedi, ndc**

Scientist 'G'

Director

Industry Interface and Technology Management



सत्यमेव जयते



एक कदम स्वच्छता की ओर

अनुसंधान तथा विकास संगठन  
Defence Research & Development Organisation  
भारत सरकार, रक्षा मंत्रालय  
Government of India, Ministry of Defence  
कमरा नं. 447, 'बी' विंग,  
Room No. 447, 'B', Wing,  
डी आर डी ओ भवन, नई दिल्ली-110011  
DRDO Bhawan, New Delhi-110011



## **MESSAGE**

DRDO develops critical defence technologies and products to meet the requirements of Indian Armed Forces. The products developed by DRDO are world class and have huge export potential. These products include range of Tactical Missiles, Armaments & Ammunitions, Sensors, Avionics, EW systems, Life Science Products, Torpedoes, Communication Systems, Engineering Systems, EO systems and so on.

Defence exports have become the necessity for survival of industries involved in manufacture of Defence products. In the prevalent world economic scenario, creation of business and growth is the need of the hour. Export plays an important role in this. DRDO provides Transfer of Technology, hand holding support and necessary policy framework to facilitate Indian industries for exports. DRDO has evolved a compendium of "DRDO Products for Export" which will provide the necessary and handy information on Defence Products. The industries can utilize this information to initiate dialogue for export with the interested friendly countries.

I congratulate 'Team DRDO', with special reference to 'Team DIITM' for their efforts in evolving the Compendium of "DRDO Products for Export". I am sure that this compendium will facilitate Indian industries to explore the potential for export of DRDO developed Defence systems/products.

Jai Hind.

( Dr Mayank Dwivedi)

Date: 3 February, 2021

Place: New Delhi







# About DRDO

**D**RDO (Defence Research & Development Organisation) is the R&D Organisation of Ministry of Defence, Government of India, with a vision to empower India with cutting-edge defence technologies and a mission to achieve self-reliance in defence technologies and systems. DRDO equips Indian Armed Forces with state-of-the-art weapon systems in accordance with requirements of Armed Forces.

DRDO was formed in 1958 with 10 establishments/ laboratories. Over the years, it has grown multi-fold in terms of the subject disciplines, number of laboratories, achievements and stature.

Today, DRDO is a network of more than 50 laboratories which are deeply engaged in developing defence technologies covering disciplines like, Aeronautics, Armaments, Electronics, Combat Vehicles, Engineering Systems, Instrumentation, Missiles, Advanced Computing & Simulation, Special Materials, Naval Systems, Life Sciences and Information Systems.

The manpower of DRDO is approximately 25,000 including 7,500 scientists, belonging to the Defence Research & Development Service (DRDS), working in the specialized technology domains.

For past six decades, DRDO has designed, developed and led to production state-of-the-art weapon systems, sensors, platforms and allied equipment for Indian Armed Forces. These products include range of Tactical Missiles, Armaments & Ammunitions, Radars, Avionics, EWS Systems, Sensors, Torpedoes, Communication Systems, Engineering Systems, Life Sciences Products, EOS Systems and many more. These systems/ equipment enhance combat effectiveness of the Services.

Indian Industry is a valuable partner of DRDO in it's endeavor. They play an important role as development partner and/ or Production agencies. The technology of all systems/ equipments is transferred to the Indian Industry for production and supply. Many of the defence technologies developed by DRDO have good potential and utility for application in commercial market too. Such technologies are also transferred to the industry for commercial market.

Today, more than 1800 industry have joined hands with DRDO in delivery of components, subsystems, systems, platforms and technologies for Indian Armed Forces. Many industries have achieved the capability and the capacity to become the lead system integrator whereas, some industry have become part of global supply chain and have started exports of DRDO developed systems to friendly countries.

DRDO supports industry in evolving the specifications of the export variant of the products (based on DRDO technology) to enable industry to respond to the RFPs of friendly nations. DRDO also carries out customization of product to meet the requirement of customer countries based on the requirement of the Industry. The "DRDO SoP for Export of Military Equipment" facilitate Indian industry and DRDO labs to provide necessary technical support to industry for responding to RFI before necessary approval from MoD is obtained by the industry. The DRDO SoP for exports is in line with the MoD SoP for exports and provide assistance to Indian industry to address the export needs of the products designed and developed by DRDO.

A number of advance test facilities and equipments are available at the Labs for trial & testing the products before acceptance by the User. DRDO provide access to the world class high end test facilities to Indian industries involved in designing, developing and manufacturing.

This compendium brings out the DRDO developed, well proven systems/ products that have been extensively trial evaluated. These products have huge export potential and many of them have already been exported to friendly countries. The production agency involved in realizing these products/ systems are also mentioned.

The export interests/ queries may be posted to the Director, Directorate of Industry Interface & Technology Management at DRDO Headquarters, New Delhi at the following address:-

Director,  
**Directorate of Industry Interface & Technology Management (DIITM)**  
Room No 447, DRDO HQrs, DRDO Bhawan, Rajaji Marg,  
New Delhi – 110011, INDIA  
011-23016216, 23007446, 011-23793008 (Fax)  
diitm@hqr.drdo.in



# Table of Contents

## MILITARY USE PRODUCT

### 1. Aeronautical Systems

1.1	Light Combat Aircraft (LCA) TEJAS	2
1.2	Airborne Early Warning and Control (AEW&C)	3
1.3	Lakshya (Pilotless test/ Target aircraft)	4
1.4	Duck Drop System for Aircraft	5
1.5	Heavy Drop Systems –16T	6
1.6	Heavy Drop Systems –3T	7
1.7	Brake Parachute For MiG-29 Aircraft	8
1.8	Brake Parachute for Su-30 Aircraft	9
1.9	Brake Parachutes for Hawk (AJT)	10
1.10	Controlled Aerial Delivery System (CADS)	11
1.11	Arrestor Barrier System	12
1.12	Identification of Friend or Foe (IFF)	13
1.13	Combat Free Fall System (CFF)	14
1.14	Computerized Pilot Selection System (CPSS)	15
1.15	Protective Equipment and Flying Clothing for Fighter Pilots	16
1.16	Microwave Chaff Cartridge-118/I	17
1.17	Integrated Life Support System	18
1.18	Anti Aircraft Simulation System (A2S2)	19
1.19	Wankel type Rotary Engine	20

### 2. Armament & Combat Systems

2.1	Arjun Main Battle Tank (MBT) Mk IA	22
2.2	Pinaka Weapon System	23
2.3	Advanced Towed Artillery Gun System (ATAGS)	24
2.4	Armoured Amphibious Dozer (AAD) MK-I	25
2.5	Armoured Engineer Reconnaissance Vehicle (AERV)	26
2.6	Armoured Recovery & Repair Vehicle (ARRV)	27
2.7	Bridge Layer Tank (BLT)	28
2.8	Multi-span Mobile Bridging System (SARVATRA)	29
2.9	Modular Bridge–46m	30
2.10	Manually Launched Assault Bridge (MLAB)	31

2.11	Short Span Bridging System-5m	32
2.12	Short Span Bridging System-10m	33
2.13	Crevasse Crossing Bridge	34
2.14	Mountain Foot Bridge-35m	35
2.15	Mat Ground Surfacing (MGS 70)	36
2.16	Wheeled Armoured Platform (WhAP) - 8x8	37
2.17	INSAS Weapons (RIFLE and LMG)	38
2.18	Joint Venture Protective Carbine (JVPC)	39
2.19	Under Barrel Grenade Launcher (UBGL)	40
2.20	Infantry Company Commander Tactical Trainer (INFCOTT)	41
2.21	Anti Tank Mine: VIBHAV	42
2.22	Anti Tank Mine: VISHAL	43
2.23	Anti Thermal Anti Laser Smoke Grenade-81 mm	44
2.24	Explosive Reactive Armour	45
2.25	Bi Modular Charge System (BMCS)	46
2.26	Counter Mine Flail System on T-72 Tank Chassis	47
2.27	Mechanical Mine Layer (Self Propelled)	48
2.28	Self-Propelled Mine Burier (SPMB)	49
2.29	Mine Field Marking Equipment	50
2.30	Bund Blasting Device	51
2.31	Remotely Operated Vehicle (ROV) - Daksh	52
2.32	Confined Space ROV - Daksh Mini	53
2.33	Surveillance ROV - Daksh Scout	54
2.34	Mobile Autonomous Robotic System (MARS)	55
2.35	Robot Sentry	56
2.36	Portable Handheld & Backpack Water Mist based Fire Fighting System	57
2.37	Explosive Identifier (e-Discerner)	58
2.38	Multi – Mode Hand Grenade	59
2.39	Parallel Probe Saturation Profiler (PPSP)	60
2.40	Multi-Parameter Probe (MPP)	61
2.41	Snow Moisture Meter (SMM)	62

### 3. Electronics & Communication Systems

3.1	3D Medium Range Surveillance Radar	64
3.2	3D Surveillance Radar- Revathi	65
3.3	3D Low Level Light Weight Radar: Aslesha Radar	66
3.4	2D Low Level Light Weight Radar	67
3.5	3D Tactical Control Radar	68
3.6	Surface Surveillance Radar	69
3.7	Battle Field Surveillance Radar – Short Range (BSFR-SR)	70
3.8	Multi Function Fire Control Radar	71
3.9	Weapon Locating Radar	72
3.10	Border Surveillance System (BOSS)	73
3.11	Advanced Driver Night Sight (A-DNS)	74
3.12	Hand Held Thermal Imager with Laser Range Finder (HHTI with LRF)	75
3.13	Holographic Sight	76
3.14	Multi-Purpose Sight	77
3.15	Stabilized Electro-Optical Sight (SEOS)	78

3.16	Stabilized Surveillance Sight (SSS)	79
3.17	VHF Frequency Hopping Radio	80
3.18	Advanced VLF Communication System	81
3.19	High-Data Rate VLF (HD-VLF) Communication System	82
3.20	Software Defined Radio-Naval Communication (SDR-NC)	83
3.21	Software Defined Radio-Tactical (SDR-TAC)	84
3.22	Quad Diversity Troposcatter Modem	85
3.23	Short Range Optical Target Locator (OTL300)-300m	86
3.24	Short Range Optical Target Locator (OTL600)-600m	87
3.25	Long Range Optical Target Locator (OTL1500)-1500m	88
3.26	Laser Dazzler for Crowd Control	89
3.27	Laser Fence	90

#### **4. Life Protection Systems**

4.1	Bullet Proof Jacket (BPJ)	92
4.2	HAPO Chamber	93
4.3	Reusable Phase Change Material (PCM) Heat packs	94
4.4	Phase Change Material (PCM) Cool Vest	95
4.5	Survival Blanket	96
4.6	Splint Inflatable	97
4.7	All Terrain Water Purification System (WPS)	98
4.8	Chemical Agent Monitor - E-Nasika	99
4.9	Iron Removal Unit	100
4.10	Flexi Saver Water Purifier	101

#### **5. Micro Electronics Devices & Computational Systems**

5.1	120W Pulsed X band Microwave Power Module (MPM)	104
5.2	100W CW C-Ku band Microwave Power Module (MPM)	105
5.3	300W Pulsed Ku band compact	106
5.4	Geographical Information system (GIS)	107

#### **6. Missile Systems**

6.1	Surface to Air Missile System - Akash	110
6.2	Beyond Visual Range (BVR) Air-to-Air Missile - Astra	111
6.3	Anti Tank Guided Missile - NAG	112
6.4	BRAHMOS Weapon System	113

#### **7. Naval Systems**

7.1	Hull Mounted Sonar for Surface Ships (HMS-X)	116
7.2	Hull Mounted Torpedo Alert System (HUMTAS-X)	117
7.3	Bow Mounted Sonar for Surface Ships (BMS-X)	118
7.4	Compact Hull Mounted Sonar for Small Surface Vessels (HMS-X2)	119
7.5	Submarine Sonar Suite (SMS-X)	120
7.6	Rubber Tiles for Submarines	121
7.7	Advanced Torpedo Defence System for Ships (ATDS-X)	122
7.8	Underwater Acoustic Communication System (UWACS TRITON)	123
7.9	Low Frequency Dunking Sonar (LFDS-X)	124



7.10	Emergency Sound Signalling Device for Submarine (ESSD)	125
7.11	Own Noise Measurement & Analysis System for Ships and Submarines (ONMA)	126
7.12	Passive Towed Array Sonar for Surface Ships (PTAS-X)	127
7.13	Advanced Light Towed Array Sonar (ALTAS-X)	128
7.14	Portable Diver Detection Sonar (PDDS-X)	129
7.15	Integrated Coastal Surveillance System (ICSS-X)	130
7.16	Sonar System Simulators	131
7.17	Heavy Weight Torpedo - Varunastra	133
7.18	Expendable Decoy - Maareech	134
7.19	Torpedo Advanced Light (TAL) – Light Weight Torpedo	135
7.20	Submarine Fired Decoy – Soft Kill Countermeasure	136
7.21	Fire Control System (Torpedo)	137
7.22	Composite Sonar Dome for Naval Ships	138
7.23	Impressed Current Cathodic Protection System (ICCP)	139
7.24	Submarine Escape Equipment	140
7.25	Naval Wargame	141
7.26	Under Water Acoustic Sensors (Hydrophones)	142
7.27	Air Droppable Container - Sahayak NG	143
7.28	Instant Fire Detection and Suppression System (IFDSS)	144

## 8. NBC

8.1	NBC Mobile Water Purification System (WPS)	146
8.2	NBC Casualty Bag Full	147
8.3	NBC Casualty Bag Half	148
8.4	NBC Decontamination Suit	149
8.5	Radiation Monitor	150
8.6	Water/ Liquid Radioactivity Contamination Monitoring System (WLRCMS)	151
8.7	Food Radioactivity Contamination Monitoring System (FRCMS)	152
8.8	Pocket Dosimeter (PDM)	153
8.9	Portable Dose Rate Meter (PDRM)	154
8.10	Roentgenometer	155
8.11	Radiation Detection Measurement and Control Unit (RADMAC)	156
8.12	Gamma Flash Sensor	157
8.13	CBRN Mini UGV	158
8.14	NBC Reconnaissance Vehicle (NBC RV)	159
8.15	Mobile CBRN Detection & Communication (MDC) Vehicle	160
8.16	NBC Protective Equipment	161

## 9. Materials

9.1	High Nitrogen Steel (HNS)	164
9.2	Solvent-Free Anticorrosive Paint	165
9.3	Heavy Duty Non-Skid Paint	166
9.4	High Performance Exterior Paint	167
9.5	Camouflage and Infrared Reflective (CAM-IRR) Paint	168
9.6	Polyurea Coatings	169
9.7	Stratified Coating	170

# Chapter - 1



## Aeronautical Systems

# 1.1

## Light Combat Aircraft (LCA) TEJAS

The Light Combat Aircraft is an indigenously developed single engine, Day/ Night, All-weather, Multi Role aircraft of 4+ generation. LCA has two distinct variants for Air Force and Navy. It is a Light weight, quick reaction aircraft with features such as Compound Delta Platform with Relaxed static stability for good maneuverability, Composite structures making it light weight, All Glass, NVG (gen 3) compatible Cockpit with good all round visibility and a fully integrated HOTAS (Hands On Throttle And Stick). The Avionics suite is modern and contemporary with Display and Sighting Helmet (DASH – 4) compatibility. An electronic warfare suite that includes both Active and Passive measures (chaff & flare), along with Radio Tx/Rx encryption feasibility, enhances survivability in an EW environment. All Navigation systems are modern and upto date TACAN, VOR/ILS/DME, INGPS.

### Salient Features:

- Max take off weight of 13.5 ton and payload upto 3.5 ton
- Seven hard points
- Tailless compound delta platform with relaxed static stability
- Max speed: 1.6 Mach
- Air to Air Refuelling
- Air to Air combat with BVR missile
- Conventional and precision attack by LGBs



Light Combat Aircraft (LCA) TEJAS

### Production Agency:

- M/s Hindustan Aeronautics Ltd,  
No.15/1, Cubbon Road, Bangalore - 560001.  
Tele-fax: 080-22320031; Email: cmd@hal-india.co.in

## 1.2

# Airborne Early Warning and Control (AEW&C)

AEW&C system can detect, identify and classify threats present in the surveillance area and act as a command and control centre to support different air operations. The system with its multiple communication and data links alert and direct fighters against threats while providing "Recognizable Air Situation Picture" to the Commanders through the Ground Exploitation Stations. It also comprises electronic and communication support measures that intercept, localize and classify hostile radar transmissions and communication signals.

### Salient Features:

- Active Array for PR & SSR
- SATCOM for voice and data communication
- ESM and CSM for detection of hostile air defences
- Self protection suite for electronic counter measures
- Mission communication system for Air-to-Air, Air-to-Ground V/UHF voice and data
- Seven operator work station and five resting crew seats
- Extendable endurance with In-flight refueling (IFR)
- Dedicated APU for Mission avionics



Airborne Early Warning and Control (AEW&C)

### Production Agency:

- M/s Centre for Airborne Systems  
Belur, Yamlur Post,  
Bangalore – 560037  
Ph: +91- 80-25049002; Email: [director@cabs.drdo.in](mailto:director@cabs.drdo.in)

1.3

## LAKSHYA (Pilotless Test/Target aircraft)

Lakshya is an advanced pilotless target aircraft. It is a cost effective, re-usable, subsonic aerial target launched either from ground or ship for training. It carries two tow targets with a tow length of 1.5 kms each having radar, IR or visual signature augmentation. These tow targets are used for training of gunners of land or shipbased guns, missile crew and combat aircraft pilots in weapon engagement.

### Salient Features:

- Zero length launcher- Rocket assisted take-off
- Transportable/ portable control station
- Maximum All-up-Weight (including two tow bodies) is 705 kg
- Endurance at 1.5 km at 0.56 Mach is 50 min
- Maximum speed in clean configuration is 0.65 Mach
- Maximum altitude is 9 km clean and 5km (with tow bodies)



Lakshya

### Production Agency:

- M/s Larsen & Toubro,  
L & T House, Ballard Estate ,  
PO Box – 278, Mumbai - 400 001.  
Tel: +91 22 67525656; Fax: +91 22 67525893; Email: [igrc@larsentoubro.com](mailto:igrc@larsentoubro.com)



1.4

# Duck Drop System for Aircraft

Duck Drop System for Aircraft is used for para dropping of four rubberized boats (GEMINIs) in their inflated condition in high seas during commando operations. It consists of a platform (for mounting/lashing four GEMINIs), a parachute system (for safe descent of the load), lashing system (for lashing/quick unleashing the boats on the platform) and buoyancy system (for enabling the platform floating in sea water when the boats are removed from the platform after their recovery for reuse).

## Salient Features:

- Platform Size : 4216 X 2802 X 193 mm
- All up Weight : 3700 kg
- Payload : 4 Boats (GEMINIs)
- Parachute System : Cluster of parachutes
- Platform Weight : 1000 Kg
- Drop Speed(Release) : 260-400 kmph
- Landing Speed : 9 m/sec (on Sea)
- Reusability : 5 times



P7 Duck Drop System for Aircraft

## Production Agency:

- Parachute: Ordnance Factory Board,  
10-A, SK Bose Road,  
Kolkata - 700 001 West Bengal.  
Ph: +91-33-22430472; Fax : +91-33-22482927; Email : sec.ofb@nic.in
- M/s Larsen & Toubro,  
L & T House, Ballard Estate,  
PO Box - 278, Mumbai - 400 001.  
Tel: +91 22 67525656; Fax: +91 22 67525893; Email: igrc@larsentoubro.com

1.5

## Heavy Drop System -16T

P-16 Heavy Drop System (HDS) comprising of Platform and Parachute Sub-system is used for para dropping of military stores in hostile terrains upto 16 Tonnes payload such as BMP, supplies and ammunition from heavy lift aircraft. This parachute system consists of multistage parachutes comprising of 5 canopies, 10 brake chutes, 2 auxiliary chutes and 01 extractor parachute.

### Salient Features:

- Platform Size : 7210 x 3210 x 220 mm
- Mass of Platform : 2700 kg
- Mass of Parachutes : 200 Kgs
- Payload Mass : 15000 kg
- Drop Altitude : 1000 - 4000 m
- Flight Speed : 320-400 Km/ h
- Drop Life : 5 drops/ 10 years
- Landing Speed : 7-8 m/s



Heavy Drop System -16T

### Production Agency:

- Parachute: Ordnance Factory Board, 10-A, SK Bose Road, Kolkata - 700 001 West Bengal.  
Ph; +91-33-22430472; Fax : +91-33-22482927; Email : sec.ofb@nic.in
- M/s Larsen & Toubro,  
L & T House, Ballard Estate, PO Box - 278, Mumbai - 400 001.  
Tel: +91 22 67525656; Fax: +91 22 67525893; Email: igrc@larsentoubro.com

1.6

## Heavy Drop System – 3T

Heavy Drop System (HDS), comprising of Platform and Platform Sub-system, enables para dropping of military stores upto 3 Tonnes from aircraft. Its parachute system consists of cluster of parachutes. It consists of a light weight platform.

### Salient Features:

- Platform Size : 4682 x 1869 x 116 mm
- Mass of Platform : 400 kg
- Mass of Parachutes : 340 Kg
- Drop Altitude : 300 - 1500 m
- Flight Speed : 190 - 240 km/h
- Landing Speed : 7.5 m/s max



Heavy Drop System – 3T

### Production Agency:

- Parachute: Ordnance Factory Board,  
10-A, SK Bose Road,  
Kolkata - 700 001 West Bengal.  
Ph; +91-33-22430472; Fax : +91-33-22482927; Email: sec.ofb@nic.in
- M/s Larsen & Toubro,  
L & T House, Ballard Estate,  
PO Box - 278, Mumbai - 400 001.  
Tel: +91 22 67525656; Fax: +91 22 67525893; Email: igrc@larsentoubro.com

1.7

# Brake Parachute for MiG-29 Aircraft

Brake Parachute has been designed to provide adequate deceleration to bring the aircraft of different weight to stop within specified landing speed in both normal and emergency condition. Single canopy brake parachute is designed to stop the aircraft, having landing weight varying from 14200-15750 kg for normal and emergency speed.

## Salient Features:

- Shape : Unicross
- Nominal Area : 17 sq.m.
- Materials : Nylon 66, Kevlar
- No. of Rigging Lines : 32
- Parachute Mass : 8.5 kg max
- Normal deployment Speed : 260 kmph
- Emergency Deployment Speed : 310 kmph
- Service life : 9 Years or 55 streamings



Brake Parachute for MiG-29 Aircraft

## Production Agency:

- Parachute: Ordnance Factory Board,  
10-A, SK Bose Road, Kolkata - 700 001 West Bengal.  
Ph; +91-33-22430472; Fax : +91-33-22482927; Email : sec.ofb@nic.in
- M/s Larsen & Toubro,  
L & T House, Ballard Estate, PO Box - 278, Mumbai - 400 001.  
Tel: +91 22 67525656; Fax: +91 22 67525893; Email: igrc@larsentoubro.com



1.8

# Brake Parachute for Su-30 Aircraft

Brake Parachute has been designed to provide adequate deceleration to bring the aircraft at different weight to stop within specified landing speed in both normal and emergency condition. Very stable twin canopies brake parachutes have been designed for aircraft landing weight varying from 21000 kg to 41000 kg for normal and emergency condition respectively.

## Salient Features:

- Shape : Unicross
- Nominal Area : 24 sq.m
- Materials : Nylon 6
- No. of Rigging Lines : 32
- Parachute Mass : 24 kg max.
- Normal deployment Speed : 260 kmph
- Emergency Deployment Speed : 300 kmph
- Service life : 10 Years or 60 streamings



Brake Parachute for Su-30 Aircraft

## Production Agency:

- Ordnance Factory Board,  
10-A, SK Bose Road,  
Kolkata - 700 001 West Bengal.  
Ph; +91-33-22430472; Fax : +91-33-22482927; Email: sec.ofb@nic.in

1.9

# Brake Parachute for Hawk (AJT)

Brake Parachute is used to assist normal wheel braking and to reduce the landing run of the aircraft. The parachute produces its maximum decelerating force immediately after opening following aircraft touchdown, or at a time when wheel brakes are not effective, especially when the runway is wet or icy.

## Salient Features:

- Aircraft Landing Mass
  - Normal : 5900 Kg
  - Maximum : 9100 Kg
- Maximum Deployment Speed : 160 Knots
- Mass of Parachute System :  $6.0 \pm 0.2$  Kg
- Service life : 8 Years or 45 streamings



Brake Parachute for Hawk (AJT)

## Production Agency:

- Ordnance Factory Board,  
10-A, SK Bose Road,  
Kolkata - 700 001 West Bengal.  
Ph; +91-33-22430472; Fax : +91-33-22482927; Email: sec.ofb@nic.in



1.10

# Controlled Aerial Delivery System (CADS)

CADS is used for precise delivery of payload up to 500 kg at predetermined location by making use of maneuverable capabilities of Ram Air Parachute (RAP). CADS uses Global Positioning System for the co-ordinates, altitude and heading sensor for the heading information during its flight. CADS with its onboard electronics unit autonomously steers its flight path toward target by operating control lanyards of RAP. The mission data are programmed in it before drop.

## Salient Features:

- Day & Night operation possible
- Payload Capacity : 500 kg (Including Skid Board)
- Drop Altitude : 1000 m (AGL) – 7620m (AMSL)
- Stand Off Distance : 2.5 times the drop Altitude
- Max Release Speed : 240 kmph
- Wind Conditions : 15 Knots (Surface Winds)
- Circular Error Probability : 100 m
- Descent Rate : 4.25 - 1.5 m/s
- Mode of Operation : Autonomous /Manual
- Forward Speed : 40 kmph



Controlled Aerial Delivery System (CADS)

## Production Agency:

- Ordnance Factory Board,  
10-A, SK Bose Road, Kolkata - 700 001 West Bengal.  
Ph; +91-33-22430472; Fax : +91-33-22482927; Email: sec.ofb@nic.in

1.11

# Arrestor Barrier System

Arrestor Barrier System stop the fighter aircraft in emergency condition during aborted take-off or landing over run with minimal damage to aircraft or injury to the crew.

## Salient Features:

- Available in two variants (20 Ton Class and 40 Ton Class).
- 20 Ton class applicable for 6-20.4 Ton Mass
- Aircraft with 170 Knot max speed.
- 40 Ton class applicable for 9-11 Ton mass Aircraft with speed of 153 knot max, 11-40 Ton mass with speed of 160 knot max.



20 Ton Class



40 Ton Class

## Production Agency:

- M/s John Galt International,  
D-213, Kanakia Zillion LBS Road,  
Kurla West, Mumbai- 400070.  
Ph; +91-22-26004962; Fax : +91-22-26006594; Email: mail@johngalt.in

## 1.12

# Identification of Friend or Foe (IFF)

Identification Friend or Foe (IFF) system is a compact, lightweight system using state-of-the-art technology and can be used for ground/ surface as well as airborne application. It operates as per the standards laid down by ICAO Annex 10 and STANAG 4193. It is designed using VME architecture that provides complete flexibility for futuristic upgrades. Operation in Mode S-level 2 gives capability of selective addressing and data link features which is very critical in dense air-traffic.

## Salient Features:

- MK XII Mode 1, 2, 3/A, C & 4 (IS1) with Mode S Level 2
- Conduction cooled ATR Chassis
- Real Time Operating System
- Extensive BITE facility
- E-Scan and M-Scan Antenna Compatibility
- Applique crypto unit
- Operating Temp: - 40 °C to +71 °C
- Environmental: MIL STD 810E/MIL STD 461E



IFF Transponder



IFF Interrogator



IFF CIT

## Production Agency:

- M/s Bharat Electronics Ltd, Outer Ring Road, Nagavara, Bangalore – 560045.  
Ph: +91- 80-25039300  
Fax: +91-80-25039211  
Email: cmd@bel.co.in
- M/s Data Patterns (I) Pvt Ltd, No -19, Arya Gowder Road, West Mambalam, Chennai - 600033.  
Ph: +91 44 4741 4000  
Fax: +91 44 4741 4444  
Email: datapatterns@datapatterns.co.in
- M/s Alpha Design Technologies Pvt Ltd, No.09, Service Road, HAL-II Stage, Indira Nagar Bengaluru - 560008.  
Ph: +91-80-4255-6909  
Fax: +91-80-2521 6541  
Email: alphacorp@adtl.co.in

1.13

# Combat Free Fall System (CFF)

CFF System provides total solution to paratrooper for jumping from as high as 30,000 feet. It provides gliding upto 30 km range and landing at desired target. System can be used in High Altitude High Opening (HAHO) and High Altitude Low Opening (HALO) modes. It consists of automatic activation device for opening of parachutes. It consists of Ram Air Parachute for main and reserve parachutes.

## Salient Features:

- Load Bearing capacity of 150 kg
- Forward Speed of 40 Kmph
- Pre Breather Console in aircraft
- Personal Bail-out Oxygen System (PBOS)
- Protective clothing (Overall, Gloves, Helmet, Anti-glare Goggles, Jump Boots)
- Helmet Mounted Communication System
- Navigation Devices (Hand Mounted Altimeter , GPS, Wrist Compass)
- Equipment carrier bag



Combat Free Fall System

## Production Agency:

- M/s Aerospace Engineers,  
NH-7 Bypass Road, Seelanaickenpatty, Salem – 636 201.  
Ph: +91 427 2422232, Fax: +91 427 2422332, Email: [mktg@thesalemaeropark.com](mailto:mktg@thesalemaeropark.com)

1.14

# Computerized Pilot Selection System (CPSS)

CPSS system captures accurate, reliable and high-speed data relating to the skills of “a candidate” appearing for pilot selection. This system has been designed with built-in diagnostic facilities for ease of maintenance. The tests comprehensively evaluate the qualities required for the military pilots such as psychomotor skills, information processing skills (speed and accuracy), coordination, visualization, time sharing, etc. by subjecting the candidates to perform concurrent multiple tasks.

## Salient Features:

- Highly accurate and reliable
- Fool proof testing
- Built in diagnostic facilities
- Easy to maintain



Computerized Pilot Selection System

## Production Agency:

- M/s Bharat Electronics Ltd,  
Outer Ring Road, Nagavara, Bangalore – 560 045.  
Ph: +91- 80-25039300; Fax: +91-80-25039211; Email: cmd@bel.co.in
- M/s Data Patterns (I) Pvt Ltd,  
No -19, Arya Gowder Road, West Mambalam, Chennai – 600033.  
Ph: +91 44 4741 4000; Fax: +91 44 4741 4444; Email: datapatterns@datapatterns.co.in



1.15

## Protective Equipment and Flying Clothing for Fighter Pilots

Protective Equipment and Flying Clothing (PE&FC) for the fighter pilots include Flame Retardant (FR) Overalls; FR Automatic Inflatable Life Jacket; FR Anti G Suit; FR Aircrew Survival Jacket; FR Gloves; Boots flying; Light Weight Integrated Helmets and Pressure Breathing Oxygen Masks. It also consists of Thermal inners; Upgraded Cold Weather Suit; Gloves with active heating elements and electronic controller and heated insoles for use by the pilots operating in high altitudes.

### Salient Features:

- Made of High Performance Textile materials ensuring excellent protection
- Performance of the items confirm to MIL standards
- Meet the critical windblast requirements of 600KEAS
- Available in different sizes to cater to the requirements of fighter pilot population



Protective Equipment and Flying Clothing  
for Fighter Pilots

### Production Agency:

- M/s Vijay Sabre Safety Pvt. Ltd,  
Plot No 35, Chandivali Village, Off Saki Vihar Road, Sakinaka, Sangharsh Nagar, Andheri (E),  
Mumbai - 400 072.  
Ph-022-28478203, Fax-022-28470021,  
Email-vijaysabre@vsnl.net; Website:www.vijaysabresafety.com



1.16

# Microwave Chaff Cartridge

## -118/I

It is an expendable electronic countermeasure. It is deployed from Aircrafts to either confuse hostile radar system or act as a decoy against radar homing missile. It consists of electrically conducting thin filaments (dia 25-30  $\mu\text{m}$ ), and forms chaff cloud of dipoles, in air, which interacts with the hostile microwave signals as decoy for aircraft self-protection. Ejection of the chaff payload is triggered either manually by the pilot or automatically by the CMDS upon receiving incoming threat warning.

### Salient Features:

- Broad coverage of radar frequency range (2 – 18 GHz)
- Generation of large Radar Cross Section (RCS  $>30 \text{ m}^2$  within 0.2 sec)
- Fast Ejection from CMDS (Ejection velocity 25 to 50 m /sec)
- Rapid dispersal bloom rate to form an effective chaff cloud



Microwave Chaff Cartridge-118/I

### Production Agency:

- M/s Economics Explosives Ltd,  
11, Zade Layout, Bharat Nagar, Nagpur – 440033.  
Ph: +91-712-2561000; Fax: +91-712-2560202; Email: [snn@solargroup.com](mailto:snn@solargroup.com)
- M/s Premier Explosive Ltd,  
Premier House No.11, Ishaq Colony, Near AOC Centre, Secunderabad – 500 015, AP.  
Ph: +91 40 6614 6801, Fax: +91 40 2784 3431, Email: [ang@pelgel.com](mailto:ang@pelgel.com)

1.17

# Integrated Life Support System

The Integrated Life Support System (ILSS) prevents in-flight Hypoxia (during high altitude flying and emergency escape) and G-Induced Loss of Consciousness (G-LOC) during high G manoeuvres. The technology consists of provisioning of breathing oxygen generated through On-Board Oxygen Generation System (OBOGS) using conditioned compressed air available from Engine bleed air and a breathing Demand Oxygen Regulator (DOR) that supplies the breathing gas to the aircrew at desired flow and pressure. It also consists of Anti-G-Valve (AGV) that inflates the Anti-G suit to apply desired counter pressure and an Electronic Controller Unit (ECU) to control, monitor and coordinate various functions of Line Replaceable Units (LRUs). All these systems are integrated in the aircraft within very limited confines of the space in the fighter aircraft.

## Salient Features:

- Effective life support system
- In built redundancy
- Life support during emergency escape through Emergency Oxygen System



Integrated Life Support System

## Production Agency:

- M/s Larsen & Toubro Ltd,  
L & T House, Ballard Estate, PO Box - 278, Mumbai - 400 001.  
Ph: +91 22 67525656; Fax: +91 22 67525893; Email: igrc@larsentoubro.com

1.18

# Anti Aircraft Simulation System (A2S2)

Anti-Aircraft Simulation System (A2S2) is designed & developed to meet the training requirements of army towards tactical handling of Air Defence batteries and troops in the field. The system enables evaluation of effectiveness of various deployment patterns of Air Defence Weapon Systems around VA/VPs deployed by various trainees against air threats planned by the Instructor.

## Salient Features:

- Enables the Instructor in planning air threats against various VA/VPs which the trainees are defending.
- Evaluates the damage to air and ground targets
- Evaluates the Measure of Effectiveness (MOE) for the deployment
- Generates statistics of various operations & in-depth history of various events during the simulation, for debriefing purposes.
- Customized GIS for terrain profile
- Mathematical models for user weapon systems and military ORBAT

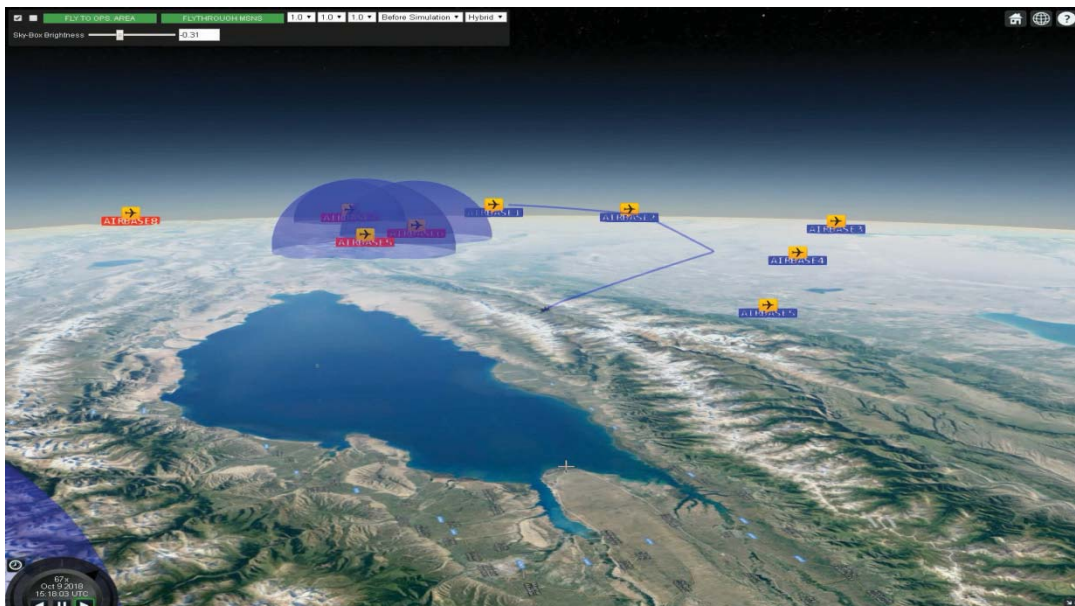

Anti Aircraft Simulation System

## Production Agency:

- DG(SAM), Room No 317, DRDO HQrs, Rajaji Marg, New Delhi - 110011.  
Ph: +91-11-23792825, Fax: +91-11-23792946, Email: dgsam@hqr.drdo.in

1.19

# Wankel type Rotary Engine

Wankel Rotary engines of 55 HP and 65 HP are the power plants for tactical Unmanned Aerial Vehicles (UAV) with an endurance in the range of 5 to 8 hrs. It has power to weight ratio of 2, with low frontal area, lesser vibrations, simplicity in construction and fewer rotating parts compared to Recuperating engine. It also finds applications in racing cars, Power hanging Gliders, rotary UAV, etc.

## Salient Features:

	55 HP Rotary engine	65 HP Rotary engine
Displacement	294 CC	345 CC
Compression Ratio	9.2	9.5
Max Power	55 hp @ 8000 rpm	65hp@8000 rpm
MIN. S.F.C.	250gm/bhp hr	250gm/bhp hr
Idle Speed	2700-2900rpm	2700-2900rpm
Ignition System	Electronic 12V dual Inductive Ignition System	Electronic 12V dual Inductive Ignition System
Fuel	Gasoline	Gasoline
Lubrication	Forced lubrication	Forced lubrication
Fuel Injection	Diaphragm Type Carburettor	Electronic fuel Injection (EFI)
Weight (Dry)	28 kg	30 kg
Overall Dimensions	480X360X320 mm	480X360X320 mm



55 HP Rotary engine



65 HP Rotary engine

## Production Agency:

- M/s Mahindra Group of Companies,  
Mahindra Towers, Dr. G M Bhosale Marg, P K Kurne Chowk, Worli, Mumbai - 400 018.  
Ph: +91 22 24931441, Fax: +91 22 24931440, Email: info@mahindra.com
- M/s Sri Vamshee Industrial Products,  
H No 4-132, Backside of St Martins High School, Ferozguda, Hyderabad - 500 011, AP.  
Ph: +91 40 23770078, Fax: +91 40 23770590, Email: vamsheeindl@yahoo.co.in



# Chapter - 2



## Armament & Combat Systems

2.1

# Arjun Main Battle Tank (MBT) Mk IA

The Arjun Main Battle Tank Mk IA is an upgraded version of Arjun MBT Mk I. Arjun MBT Mk IA offers the troops a state-of-the-art tank with superior firepower, high mobility, excellent protection and accommodates four men Crew. The Arjun MBT Mk IA is capable of firing varieties of ammunition like FSAPDS with enhanced penetration, HESH, Thermo-Baric (TB) ammunition, Penetration Cum Blast (PCB) ammunition to engage variety of targets. It has excellent agility along with excellent obstacle crossing capabilities.

## Salient Features:

- Day and night surveillance capability
- Dynamic Firing Automatic Target Tracker (ATT) for enhanced accuracy
- Remotely Controlled Weapon Station (RCWS) for AD gun
- Advance Running Gear System (ARGS) with new track system
- Night driving with Driver Night Sight (DNS)
- Advanced Land Navigation System
- Containerised Ammunition Bin with Individual Shutters (CABIS) for crew safety
- Enhanced protection against shaped charges with Explosive Reactive Armour (ERA)
- Roof Mounted Driver's Seat (RMDS)
- Laser Warning and Countermeasure System with RGL(LWCS)
- Track Width Mine Plough (TWMP) to provide safe lane for tank column



Arjun Main Battle Tank (MBT) Mk IA

## Production Agency:

- Ordnance Factory Board,  
10-A, SK Bose Road,  
Kolkata - 700 001 West Bengal.  
Ph: +91-33-22430472; Fax : +91-33-22482927; Email: sec.ofb@nic.in



2.2

# Pinaka Weapon System

Pinaka is an all weather, indirect fire, free flight artillery multi barrel rocket system. It delivers a devastatingly lethal and responsive fire against a variety of area targets such as exposed enemy troops, armoured and soft skin vehicles, communication centres, air terminal complexes, fuel and ammunition dumps. The system consists of Rocket, Multi Barrel Rocket Launcher (MBRL), Battery Command Post (BCP), Loader cum Replenishment (LCR) Vehicle, Replenishment Vehicle (RV) and Digicora MET Radar. It is configured around a rugged 8 x 8 high mobility military vehicle with excellent cross-country mobility.

## Salient Features:

- Range: 40 Km
- Fire rate: 72 rockets in 44 sec
- Mobile launching platform for 12 rockets carried in 2 pods
- A hydraulic vehicle stabilization system with auto levelling facility
- Accurate laying of the launcher through microprocessor based electric servo drive
- Secure VHF radio communication
- An autonomous navigation and orientation capability.



Pinaka Weapon System

## Production Agency:

- M/s Economics Explosives Ltd, 11, Zade Layout, Bharat Nagar, Nagpur – 440 033.  
Ph: +91-712-2561000; Fax: +91-712-2560202; Email: snn@solargroup.com
- Ordnance Factory Board, 10-A, SK Bose Road, Kolkata - 700 001, West Bengal.  
Ph: +91-33-22430472; Fax : +91-33-22482927; Email : sec.ofb@nic.in
- M/s Tata Group of Companies, Bombay House, 24, Homi Modi Street, Fort, Mumbai –400 001.  
Ph:+91 (22) 6665 8282; Fax:+91 (22) 6665 8080; Email:info@tata.com
- M/s Larsen & Toubro Ltd, L & T House, Ballard Estate, PO Box-278, Mumbai - 400 001.  
Ph: +91 22 67525656; Fax: +91 22 67525893; Email: igrc@larsentoubro.com

2.3

# Advanced Towed Artillery Gun System (ATAGS)

ATAGS is a large calibre artillery gun system configured with an all electric drive. It has better accuracy, advanced fire control system, extended range and multiple round simultaneous impact capability with surveillance and sighting systems onboard.

## Salient Features:

- 155mm, 52 calibre artillery gun
- Range: 48 kms
- Weight: 18 Ton
- Crew: 6 to 8 personal
- Fire 3 rounds in 15 second in burst mode
- In sustained mode rate of fire of 60 rounds in 60 minutes



Advanced Towed Artillery Gun System (ATAGS)

## Production Agency:

- M/s Bharat Forge Ltd,  
Mundhwa, Pune - 411 036, Maharashtra.  
Ph: +91-20-67042777, Fax: +91-20-26822387  
Email: info@bharatforge.com

2.4

# Armoured Amphibious Dozer (AAD) MK-I

AAD on BMP-II chassis is fully tracked, amphibious Dozer. It provides integral engineering support to battle groups by reducing banks of water obstacles to facilitate construction of wet/ dry assault bridges and construction & improvement of existing tracks. It is an agile equipment with high efficiency.

## Salient Features:

- Combat Load Mass: 14.8 ton
- Hydraulic winch with 8 ton capacity
- 02 Crew (Driver & Operator)
- Bucket mounted jib crane



Armoured Amphibious Dozer MK-I

## Production Agency:

- Ordnance Factory Board,  
10-A, SK Bose Road, Kolkata - 700 001, West Bengal.  
Ph: +91-33-22430472; Fax : +91-33-22482927; Email: sec.ofb@nic.in



2.5

## Armoured Engineer Reconnaissance Vehicle (AERV)

AERV on BMP-II vehicle with amphibious capability, performs reconnaissance operations to meet the tactical and combat requirements of the Military Engineers for carrying out terrestrial and underwater survey in hostile terrains. It provides Military co-ordinate position, updates data every second, calculates the target position and navigates vehicle through multiple way points with average positional accuracy of 50 to 200 m.

### Salient Features:

- Capable of testing soil condition and predict the mobility of Military vehicles
- Useful on non-co-operative targets for ranging, slope and height measurement during day & night conditions, up to a distance of 2000 m
- Evaluates, displays and records water depth, sediment layer thickness and type of underwater soil
- Plots bed profile of water obstacle on thermal printer



Armoured Engineer Reconnaissance Vehicle

### Production Agency:

- Ordnance Factory Board,  
10-A, SK Bose Road, Kolkata - 700 001, West Bengal.  
Ph: +91-33-22430472; Fax : +91-33-22482927; Email: sec.ofb@nic.in
- M/s Bharat Electronics Ltd,  
Outer Ring Road, Nagavara, Bangalore – 560045.  
Ph: +91- 80-25039300; Fax: +91-80-25039211; Email: cmd@bel.co.in

2.6

## Armoured Recovery & Repair Vehicle (ARRV)

ARRV is a Armoured Recovery and Repair Vehicle derived from Arjun Main Battle Tank. It is primarily a supporting vehicle for the mechanized forces and meant to render requisite recovery & repair cover for heavy military equipment. Its functions includes winching, towing & pushing, lifting & moving with load, anchoring, dozing, welding, cutting, replenishing, maintenance & repair services in the field, provision of power supply & power operated tools and battery charging.

### Salient Features:

- Capability of recovering bogged down vehicles from different terrain
- Anchor-cum-Dozer for anchoring and earth work
- 50 T Main Winch
- 2 T Aux Winch
- 20 T Crane operation
- Emergency Repair operations through APU
- Gas & Arc Welding and Cutting facilities with Complete set of tools for immediate repair
- Two way communication facility
- Inbuilt remote control weapon system



Armoured Recovery & Repair Vehicle

### Production Agency:

- M/s BEML,  
5th Floor, Unity Building, JC Road City, Bangalore – 560 002.  
Ph: +91 80 22224458; Fax: +91 80 22224456; Email: office@dd.beml.co.in

# 2.7

## Bridge Layer Tank (BLT)

BLT is a fast and reliable bridge laying system built on track chassis. It is capable of launching a 20m/22m long bridge with a width of 4m within 5 minutes on any wet or dry obstacles. The launching mechanism is supported by hydraulic system for launching and retrieval operations. It has a separate auxiliary engine for contingencies.

### Salient Features:

- Load class of bridge superstructure : 70 ton
- Microprocessor based control system
- In-built safety features
- Gap measuring instrument and bridge marker rods
- Bridge can be fully decked with the help of panels
- Smoke Grenade Discharger
- Fire Fighting System for safety of the vehicle
- Air Defence Machine Gun for the safety of the crew



Bridge Layer Tank (BLT)

### Production Agency:

- Ordnance Factory Board,  
10-A, SK Bose Road,  
Kolkata - 700 001 West Bengal.  
Ph: +91-33-22430472; Fax : +91-33-22482927; Email : sec.ofb@nic.in



2.8

# Multi-span Mobile Bridging System (SARVATRA)

Sarvatra, state-of-the-art bridging system is built on 8 x 8 Tatra Vehicle. It offers versatile bridging solutions for all types of military traffic for negotiating wet or dry obstacles of up to 75m span in steps of 15m, within 100 minutes. It can be used as an emergency bridge during natural calamities like floods and earthquakes.

## Salient Features:

- Carrier vehicle: Tatra 815 VVN
- Load class: 70 ton
- Obstacles depth: 2.5m – 6.0m
- Fully decked bridge: single span length – 15m and width 4m
- Rear cabin with dual drive facilities



Multi-span Mobile Bridging System, Sarvatra

## Production Agency:

- M/s BEML,  
5th Floor, Unity Building, JC Road City, Bangalore – 560 002.  
Ph: +91 80 22224458; Fax: +91 80 22224456; Email: office@dd.beml.co.in

2.9

## Modular Bridge-46m

46m modular bridge is a mechanically launched single span bridging system which can be deployed over wet/dry gap of different span varying from 14m to 46m. The equipment can be operated in plain, desert and semi-desert terrain during day and night conditions by a crew of 6 + 1 (commander).

### Salient Features:

- Mechanical launching of bridge without access of far end in 90 minutes
- Load class: 70 ton
- Military load class 70 both tracked and wheeled vehicles
- System mounted on 10x10 HMT and 8x8 HMT
- Launching time : 90 minutes (for 46 m span)



Modular Bridge

### Production Agency:

- M/s Larsen & Toubro Ltd,  
L & T House, Ballard Estate, PO Box-278, Mumbai - 400 001.  
Tel: +91 22 67525656; Fax: +91 22 67525893; Email: igrc@larsentoubro.com

2.10

## Manually Launched Assault Bridge (MLAB)

The Manually launched Assault Bridge is a deck-type two girder bridge system. Fully modular and pin-joined structure with inter-locking components provides 4m wide roadway. The standard double storey bridge can bridge gaps of up to 31 m. This capability can be extended to 49 m using ancillary equipment. MLAB is simply constructed using two parallel girders consisting of top panels each 1.83m long that can be pinned together.

### Salient Features:

- Light weight alloy construction
- Load class: 60 ton
- Low maintenance and suitable for tropical climates
- Quick to construct with minimum manpower
- Palletised load and interchangeability of components
- Little or practically no site preparation



Manually launched Assault bridge (MLAB)

### Production Agency:

- Ordnance Factory Board,  
10-A, SK Bose Road, Kolkata - 700 001, West Bengal.  
Ph: +91-33-22430472; Fax : +91-33-22482927; Email: sec.ofb@nic.in

# 2.11

## Short Span Bridging System-5m

Short Span Bridging System is a mechanically launched bridging system of MLC-70 load class to bridge the smaller gaps and canals. This bridging system has been built on tracked vehicle (BMP-II) and wheeled vehicle Tatra (6 × 6). It provides mobility to the Armed Forces by speedy establishment of bridge. This bridging system can bridge gaps from 5m length to 75m length.

### Salient Features:

- Pick and place bridge over gap
- Quick construction with minimum crew
- Beta light for deployment at night



5m Short Span Bridging System

### Production Agency:

- M/s BEML,  
5th Floor, Unity Building, JC Road City, Bangalore – 560 002.  
Ph: +91 80 22224458; Fax: +91 80 22224456; Email: office@dd.beml.co.in



2.12

## Short Span Bridging System-10m

It is a mechanically launched short span bridging system of MLC-70 load class to bridge the smaller gaps and canals. It is compatible with Sarvatra bridging system so that various gaps from 10m length to 75m length can be bridged. It is built on 8 × 8 Tatra vehicle.

### Salient Features:

- High mobility launching platform suitable for heaviest military traffic
- Double 'A' shaped trestle provides excellent stability
- Quick construction with minimum crew
- Beta light for deployment at night



10 m Short Span Bridging System

### Production Agency:

- M/s BEML,  
5th Floor, Unity Building, JC Road City, Bangalore – 560 002.  
Ph: +91 80 22224458; Fax: +91 80 22224456; Email: office@dd.beml.co.in



2.13

## Crevasse Crossing Bridge

The crevasse crossing bridge is fabricated using light weight, high strength, weldable and self-ageing aluminium alloy for crossing crevasses in snow bound areas. It enhances the mobility of troops, arms, ammunition and supplies in these regions. The bridge is a two-girder bridging system. Detachable railings are provided for safety. The bridge is designed for a load up to 550 kg i.e. snow scooter + pay load, besides limited uncleared fresh snow. The bridge is launched across the crevasse manually, with the help of a nose launching assembly.

### Salient Features:

- Bridge length : 10 m
- Roadway width : 1.75m
- Construction time : 30 minutes
- Interchangeable components
- Anti-skid deck
- Man portable modules



Crevasse Crossing Bridge

### Production Agency:

- M/s Shiva Engineering Works,  
2, India Exchange Place, Kolkata - 700001.  
Ph: +91-33-22301315; Fax: +91 33 2230 7383; Email: business@shivaengg.com

2.14

## Mountain Foot Bridge-35m

Mountain Foot Bridge (MFB) is a light weight and modular bridge which clears bridge up to 32m with a pathway of 0.8 m. Its each module is man-portable and weighs less than 18kg. It is also capable of withstanding conditions prevailing in glacial regions. The bridge normally does not allow any appreciable accumulation of fresh snow due to provision of gaps in the deck, however bridge is still designed for accumulation of 250mm of fresh snow with a density of 200 kg/ m<sup>3</sup>.

### Salient Features:

- Material: High strength Aluminium alloy
- Man Portable (Wt less than 18 kg)
- Launching time of Bridge is 120 minutes with a crew of 30 (for 32 m )
- Easy assembly in cold regions
- Compact modules to facilitate easy launch



35 m Mountain Foot Bridge

### Production Agency:

- M/s EM Electro-Mechanical Pvt Ltd,  
31 Sector-E, Industrial Area, Govindpura Bhopal 462 063.  
Ph: + 91-755-4022100; Fax: + 91-755 – 2581041; Email: atul@emtanks.com
- M/s Worldwide Oilfield Machine Private Ltd,  
India Gate No 778, at Post Velu, Satara Road, Tal. Bhor, Pune-412 705.  
Ph: +91 8308210300; Email: harshg@womindia.com
- M/s Walchandnagar Industries Ltd,  
3 Walchand Terraces, Tardeo Road, Mumbai – 400 034, Maharashtra.  
Ph: +91 (022) 23612195; Fax : +91 (022) 2363 4527; Email: gsagrawal@walchand.com

2.15

## Mat Ground Surfacing (MGS 70)

Mat Ground Surfacing CL-70 is a trackway expedient which provides smooth movement of tracked and wheeled vehicles during the movement of troops in marshy terrains, shallow waters of up to 1m depth and soft soils. It is an assembly of aluminium alloy extruded planks 4.5m wide forming a standard length of 50m. The platform is mounted on a Tatra T815, 8 x 8 vehicle. In addition to its primary role as a folding mat, the trackway can be laid and used on approach to bridge sites, shallow rivers, marshy areas and road diversions.

### Salient Features:

- Load class : MLC-70
- Total weight of roll 8500 kg (50 m)
- Life of mat 2000 passes of heaviest vehicle
- Good corrosion resistance
- Suitable for under water applications
- Hydraulic laying and retrieval system



Mat Ground Surfacing

### Production Agency:

- M/s BEML,  
5th Floor, Unity Building, JC Road City, Bangalore – 560 002.  
Ph: +91 80 22224458; Fax: +91 80 22224456; Email: office@dd.beml.co.in

2.16

## Wheeled Armoured Platform (WhAP) - 8x8

WhAP 8x8 is a wheeled armoured amphibious platform for variety of roles such as Armoured Personnel Carrier (APC), Recce and Support vehicle, CBRN vehicle etc. The system has high power engine that can be configured for three power ratings with automatic transmission, driveline along with hydro gas suspension, run flat tyres capability with CTIS and modular ballistic & blast protection.

### Salient Features:

- Fully Automatic Transmission
- Double Floor V-type mine protection chassis with shock resistant seats and foot pads
- Power operated rear door ramp
- Modular Add-on ballistic protection
- Survivability enhancers - IFDSS - NBC



Wheeled Armoured Platform

### Production Agency:

- M/s Tata Group of Companies,  
Bombay House, 24, Homi Modi Street, Fort, Mumbai –400 001.  
Ph:+91 (22) 6665 8282; Fax:+91 (22) 6665 8080; Email: info@tata.com



2.17

## INSAS Weapons (RIFLE and LMG)

INSAS Rifle and LMG designed to fire 5.56 x 45 mm calibre ammunition. It is available in Fixed Butt and Folding Butt versions. It is a compact weapon with minimal recoil and transparent magazine to count remaining bullets.

### Salient Features:

- Rifle
  - Burst of three rounds
  - Single shot
  - Mass : 4.15 kg
  - Range : 400 m
- LMG
  - Single Shot
  - Automatic
  - Mass : 5.87 Kg
  - Range : 700 m



INSAS Weapons

### Production Agency:

- Ordnance Factory Board,  
10-A, SK Bose Road, Kolkata - 700 001, West Bengal.  
Ph: +91-33-22430472; Fax : +91-33-22482927; Email: sec.ofb@nic.in



2.18

## Joint Venture Protective Carbine (JVPC)

JVPC is a carbine with a caliber of 5.56 x 30 mm. It is compact, light weight and easy to maneuver. It has low recoil and can be fired with single hand. Its firing mechanism is semi bull-pup. It is compatible to accessories like silencer, bayonet, blank firing, attachment etc.

### Salient Features:

- Mass : 3.05 kg
- Range : 200 m
- Capability to defeat soft body amour at 200m range
- Amenable to mount international optical sights
- Caliber 5.56 × 30mm, performance parameters between pistol and riffle
- Provided with accessories like silencer, bayonet, blank firing attachments, etc.



Joint Venture Protective Carbine

### Production Agency:

- Ordnance Factory Board,  
10-A, SK Bose Road, Kolkata - 700 001, West Bengal.  
Ph: +91-33-22430472; Fax : +91-33-22482927; Email: sec.ofb@nic.in

2.19

## Under Barrel Grenade Launcher (UBGL)

The Under Barrel Grenade Launcher is an add on attachment to the INSAS Rifle as well as on the AK-47 Rifle. The Launcher is made of aluminium alloy. It can fire all type of grenades upto a range of 400m. It is effective against enemy soldiers hiding in bunkers or behind walls.

### Salient Features:

- Mass : 1.5 kg
- Can fire any international grenade of 40 x 46 mm caliber
- Provided beta light sight for night firing capability
- Fills tactical gap between maximum range of hand grenade and minimum range of mortar
- Can be fired from shoulder



Under Barrel Grenade Launcher

### Production Agency:

- Ordnance Factory Board,  
10-A, SK Bose Road, Kolkata - 700 001, West Bengal.  
Ph: +91-33-22430472; Fax : +91-33-22482927; Email: sec.ofb@nic.in

2.20

# Infantry Company Commander Tactical Trainer (INFCOTT)

INFCOTT is a single PC based software tool for Army to provide training for Infantry Subunit Commanders in tactical planning of Infantry defensive & offensive operations which includes: Deployment of Infantry Company and Employment of Major Weapon Systems. Offensive operations include attack by Light Infantry Regiment (LIR) with support of Mechinf, Armoured and Artillery to capture the defended areas in various phases. The software assesses the efficacy of the commander's plans.

## Salient Features:

- Aims to train infantry subunit commanders in planning defensive operations and offensive operations on plain, desert, coastal, and mountainous terrain for a given tactical and battle field situation.
- Deployment of an infantry company up to section level & employment of weapon system & forward zone elements in defence against an infantry battalion regiment attack.
- Attack by an infantry battalion/regiment with support of mechanised force elements and artillery against an infantry company deployed in enemy defended locality.
- Efficacy of defensive & offensive operation plans and combat resolution is assessed.

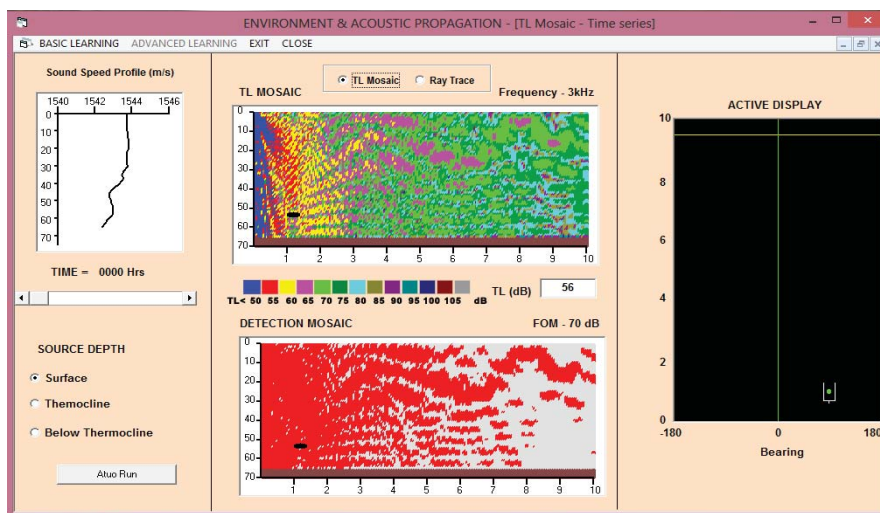

Infantry Company Commander Tactical Trainer (INFCOTT)

## Production Agency:

- DG(SAM), Room No 317, DRDO HQrs, Rajaji Marg, New Delhi - 110011.  
Ph: +91-11-23792825, Fax: +91-11-23792946, Email: dgsam@hqr.drdo.in

2.21

## Anti Tank Mine: VIBHAV

A land based, anti-tank and point attack munitions for all types of terrains under all environmental and climatic conditions. It is designed to incapacitate all types of MBTs with or without trawl running over the munitions. VIBHAV is designed for both manual and mechanical laying in the field. The lethality in terms of the blast parameters is improved by incorporating RDX/TNT (60/40). It has an arming delay for safe laying. Anti-removal (Anti – disturbance) feature of the VIBHAV is ensured by incorporating an electronic unit called Tilt Sensing and Initiating Unit. It is MEMS based device for sensing the disturbances and then initiate the detonator.

### Salient Features:

- Delayed arming for safety during laying
- MEMS based in-bulit anti removal device
- Mechanical Laying
- Larger actuation area for better kill probability
- Provides self-neutralization for safe recovery



VIBHAV

### Production Agency:

- M/s Bharat Forge Ltd,  
Mundhwa, Pune - 411 036, Maharashtra.  
Ph: +91-20-67042777, Fax: +91-20-26822387  
Email: info@bharatforge.com
- M/s Economics Explosives Ltd,  
11, Zade Layout, Bharat Nagar, Nagpur – 440033, Maharashtra.  
Ph: +91-712-2561000, Fax: +91-712-2560202, Email: snn@solargroup.com

2.22

## Anti Tank Mine: VISHAL

It is land based anti tank bar munitions for all types of terrains under all environmental and climatic conditions. It is designed to incapacitate all types of MBTs with or without trawl running over the munitions. It can be laid both manually and mechanically in the field. The provision of fuze separately from munition provides the safety during handling and transportation. The bar munition is designed to focus the effects of the explosive blast. The lethality is improved by incorporating RDX/TNT (60/40) as the main charge and the shape of the charge. It has an arming delay for safe laying. Anti-removal (Anti-disturbance) feature in VISHAL is incorporated as an electronic unit called Tilt Sensing and Initiating Unit.

### Salient Features:

- Shaped charged for enhanced lethality
- Delayed arming for safety during laying
- MEMS based in-bulit anti removal device
- Amenable to mechanical laying
- Longer actuation area for better kill probability



VISHAL

### Production Agency:

- M/s Bharat Forge Ltd,  
Mundhwa, Pune - 411 036, Maharashtra.  
Ph: +91-20-67042777, Fax: +91-20-26822387, Email: info@bharatforge.com
- M/s Economics Explosives Ltd,  
11, Zade Layout, Bharat Nagar, Nagpur – 440033, Maharashtra.  
Ph: +91-712-2561000, Fax: +91-712-2560202, Email: snn@solargroup.com



2.23

## Anti Thermal Anti Laser Smoke Grenade-81 mm

It is a red phosphorous based 81 mm Anti Thermal Anti Laser Smoke Grenade to defeat laser and Thermal Imaging (TI) sights of the Tanks in the battlefield to enhance survivability. It is capable of creating instantaneous smoke screen capable of obscuring electro-optic equipment. It is bursting and burning type of grenade which bursts in mid air/ ground at 50-70 m from the firer tank.

### Salient Features:

- Fired from 81 mm caliber launcher mounted on AFVs to a distance of  $65 \pm 10$ m within  $3.8 \pm 0.3$  seconds
- Functions on receiving an electric impulse from the AFVs
- Generates smoke screen of 30m wide and 10m height for more than 20 seconds with a salvo of 4 grenades



81 mm Anti Thermal Anti Laser Smoke Grenade

### Production Agency:

- M/s Economics Explosives Ltd,  
11, Zade Layout, Bharat Nagar, Nagpur – 440033.  
Ph: +91-712-2561000, Fax: +91-712-2560202, Email: [snn@solargroup.com](mailto:snn@solargroup.com)

2.24

## Explosive Reactive Armour

Explosive Reactive Armour (ERA) is an add on armour on tanks which consists of a layer of high explosive sandwiched between metal plates. On attack by High Explosive Anti Tank (HEAT) and Kinetic Energy (KE) ammunition, the explosive detonates and drives the metal plates apart to reduce their penetration capability.

### Salient Features:

- Minimum collateral damage and No sympathetic detonation between adjacent panels
- Safe to handle and Easy for fitment & replacement
- Effective even after deep fording
- Shelf Life: 15 years
- Weight of ERA for typical tank: 1.6 Ton



Explosive Reactive Armour

### Production Agency:

- Ordnance Factory Board,  
10-A, SK Bose Road, Kolkata - 700 001, West Bengal.  
Ph: +91-33-22430472, Fax : +91-33-22482927, Email : sec.ofb@nic.in

2.25

## Bi Modular Charge System (BMCS)

Bi-Modular Charge System has been developed for 155 mm artillery guns. BMCS consists of two type of charges – Lower Zones (LZ) for shorter ranges and Higher Zones(HZ) for longer ranges. The BMCS suits various guns like 39 cal Bofors & ULH, 45 cal Soltam, 52 cal ATAGS, with requisite range tables. Secondary ammunition like HE, illuminating or Smoke can also be fired with BMCS.

### Salient Features:

- Operable over a wide range of temperature range of -30 °C to +55 °C
- Adopted for 155 mm 45 Cal Soltam Gun
- Faster loading operation enabling higher rate of fire
- No leftover charges during training and field operation resulting in reduction of wastage
- Better safety management of store than bagged charges
- Modular Design to meet user Requirement
- Debris –free burning



Bi Modular Charge System

### Production Agency:

- M/s Economics Explosives Ltd,  
11, Zade Layout, Bharat Nagar, Nagpur – 440033.  
Ph: +91-712-2561000, Fax: +91-712-2560202, Email: [snn@solargroup.com](mailto:snn@solargroup.com)

2.26

## Counter Mine Flail System

The Counter Mine Flail (CMF) is a flailing system mounted on a track chassis capable of removing 100% of all kinds of anti-tank and 95% of anti-personnel mines. During flailing operation, complete flailing system rotates and comes in front of tank. Then rotors of flailing system with flexible chains and hammers attached on it rotate at 400 RPM. The hammer strikes the ground, digging out all the soil up to 20cm depth creating 4.5 m wide safe lane and physically breaks/disintegrates the mines and throws away, thus making it ineffective.

### Salient Features:

- Average Flailing speed : 2 kmph
- Can withstand A/T mine blast upto 9 kg TNT equivalent
- Can be operated with 02 nos of crew members
- Automatic controls to maintain the rotors at constant height above ground
- Can be deployed in less than 5 mins



CMF in Transportation Mode



CMF in Flailing Mode

### Production Agency:

- Godrej Precision Engineering,  
Plant-09, Marketing Department, Godrej & Boyce Mfg. Co. Ltd,  
Pirojshanagar, Vikhroli, Mumbai -400 079.  
Ph. No.: 022-67962953/2952/ 2951/2950, Fax No.: 022- 67963929, Email: pesmktg@godrej.com



2.27

## Mechanical Mine Layer (Self Propelled)

The Bar Mine Layer equipment is a fully automatic electronic control equipment which carries out trenching and dispensing of anti-tank ND Mk III/IV mines (Bar Mines). The equipment can lay mines in plain, desert and semi-desert soil. It stores 338 mines in two containers and can auto-dispense it to burying system. The trenching system creates trench and then the mine is placed into the trench through chute. The camouflaging system camouflages the mine while the vehicle is moving. Integrated GPS system auto-record the location of mines. On board navigation & display system aids driver for guidance during mine laying operation.

### Salient Features:

- Based on HMV 8×8 VVN
- Mine Laying rate : 250-300 mines/hr at 6m spacing
- Inter-mine spacing : 6,9,12 m with 15% variation
- Depth of trench : 0-20 cm
- Mine recording accuracy within 10 cm
- Independent engine for trenching and mine laying
- Mine laying on slopes (Longitudinal 100/120, Transverse 70/90)



MML- SP in Transportation Mode



MML- SP in Operational Mode

### Production Agency:

- Godrej Precision Engineering,  
Plant-09, Marketing Department, Godrej & Boyce Mfg. Co. Ltd,  
Pirojshanagar, Vikhroli, Mumbai -400 079.  
Ph. No.: 022-67962953/2952/ 2951/2950, Fax No.: 022- 67963929, Email: pesmktg@godrej.com



2.28

## Self-Propelled Mine Burier (SPMB)

SPMB is a semi-automatic equipment on 8x8 HMV for laying of 4 different types of Anti-Tank Mines in combat scenario. It operates in plain, desert and semi-desert terrain during day and night conditions. The equipment is integrated with state-of-the-art hydraulic system, control system, power pack and DGPS/GIS for different operations. The equipment can be operated by 4 persons excluding driver.

### Salient Features:

- Capable to lay anti-tank (A/T) mines – ND MK-I, AD MK-I & MK-II, HPDF-II
- 350 nos. of A/T mines can be stored on-board
- The equipment can lay 200 mines/hr in plains, desert and semi-desert terrain.
- Mines can be laid on surface or buried at a depth of 15 to 25 cm below the ground surface.
- Inter-mine spacing can be selected as 3 to 30m in steps of 3, 6, 9, 12, 15 & 30m.
- The equipment is integrated with mil grade electronic controller and DGNSS for data recording, mine layout planning and decision making.



Self Propelled Mine Burier

### Production Agency:

- M/s BEML Ltd,  
5 Floor, Unity Building, JC Road City, Bangalore – 560 002.  
Ph: +91 80 22224458; Fax: +91 80 22224456; Email: office@dd.beml.co.in

2.29

## Mine Field Marking Equipment

Mine Field Marking Equipment is a TATRA 6x6 based system, designed for speedy marking/fencing of mine fields with minimal human intervention. Marking/fencing is carried out with the help of Long angle Iron Pickets (LAIPs) and rope. The pickets are placed mechanically with the help of this equipment at an interval of 10/15 meters and then rope is tied at two locations on to the picket thus making a fence around the minefield.

### Salient Features:

- It is a semi-automated equipment designed to operate in plains, semi desert & desert terrain in all weather.
- Equipment can store maximum 500 Nos. of pickets & 15 km of polypropylene rope
- Equipment can be operated by a crew of 4 and vehicle driver.
- Fencing rate: maximum 1.2 km/hr.
- The equipment records the details of fencing operation like picket number, burying depth and inter-picket spacing etc.



Mine Field Marking Equipment

### Production Agency:

- M/s BEML Ltd,  
5 Floor, Unity Building, JC Road City, Bangalore – 560 002.  
Ph: +91 80 22224458; Fax: +91 80 22224456; Email: office@dd.beml.co.in

2.30

## Bund Blasting Device

Bund Blasting Device (BBD) is used to reduce the height of Ditch –cum-Bund (DCB) obstacles to enhance the mobility of mechanized infantry during wartime. The system consists of light weight stand, hollow charge initiation device and HE filled projectile attached to a rocket motor. The hollow charge on initiation creates a deep pilot hole. The HE projectile on entering this hole detonates and creates a big crater, thus fulfilling the requirement.

### Salient Features:

- Man portable
- Single action functioning.
- Breach dimensions created by an array of three devices of BBD MK II
 

Breach Length :	9.0 m
Breach Width :	5.0 m
Breach Depth :	2.5 m
- Deployment and functioning time of an array of three devices is 45 to 55 minutes



Bund Blasting Device

### Production Agency:

- M/s Economics Explosives Ltd,  
11, Zade Layout, Bharat Nagar, Nagpur – 440033.  
Ph: +91-712-2561000, Fax: +91-712-2560202, Email: [snn@solargroup.com](mailto:snn@solargroup.com)

2.31

## Remotely Operated Vehicle (ROV) - Daksh

The Remotely Operated Vehicle (ROV) is a versatile equipment for improvised explosive device (IED) identification and handling. It can also be utilised to survey and monitor nuclear and chemical contamination levels. The ROV has stair climbing capabilities and can operate continuously for 3 hours. The ROV can be controlled either by fibre optic communication over 100 m distance or can be controlled by wireless communication over 500m line of sight.

### Salient Features:

- Complete 6 degree of freedom manipulator arm
- Payload lifting capability of 20 kg (at 2.5 m arm)
- Extendable arm up to 4 m
- In-situ X-Ray of suspected objects
- On-board water jet disrupter
- On board shotgun for blasting door locks
- Vehicle towing capability



ROV Daksh

### Production Agency:

- M/s Bharat Electronics Ltd, Outer Ring Road, Nagavara, Bangalore – 560 045.  
Ph: +91- 80-25039300, Fax: +91-80-25039211, Email: cmd@bel.co.in
- M/s Dynalog Ltd, G-Wing, Kailash Vaibhav, Vikhroli West, Mumbai - 400 079.  
Ph: +91 22 25181900, Fax: +91 22 25181930, Email: r.mahendra@dynalogindia.com
- M/s Theta Controls, 1, Electronic Estate, Satara Road, Pune - 411 009.  
Ph: +91 20 24222556, Fax: +91 20 24222553, Email: sales@thetacontrol.com
- M/s Hi-Tech Robotics Pvt Ltd, Plot No. 136, Pace City -1, Sec-37, Gurgaon - 122001.  
Ph:- +91(124)4715300, Fax:- +91(124)4715398, Email:- marketing@hitechroboticsystemz.com



2.32

## Confined Space ROV - Daksh Mini

The Confined Space ROV – ‘Daksh Mini’ can handle IEDs, scan using a portable X-Ray equipment and also defuse the IED using a recoilless Water Jet Disrupter within the confined spaces like inside a train or aircraft. This compact unmanned robot can be deployed to reach the cabin baggage space inside aircrafts or the berths in a railway compartment and extract any suspected baggage. This platform is all weather and capable of being tele-operated in day or night conditions.

### Salient Features:

- Manipulator Arm with a vertical reach upto 2.5 m from the ground.
- The arm has a lifting capability of 8kg at 1m in horizontal position from the center of its base.
- It permits swivel of arm in horizontal plane up to +/- 60 degree.
- Operation range of 200m line of sight.
- Climbing capability: 40 degree slope/stair with maximum 200 mm riser height.
- Speed up to 2 kmph on flat surface.
- The Master Control Station with a display for real time video from camera
- Two hours endurance
- Approx.1050mmx440mmx850mm(LXWXH)



Daksh Mini - Confined Space ROV

### Production Agency:

- M/s Bharat Electronics Ltd, Outer Ring Road, Nagavara, Bangalore – 560 045.  
Ph: +91- 80-25039300, Fax: +91-80-25039211, Email: cmd@bel.co.in
- M/s Dynalog Ltd, G-Wing, Kailash Vaibhav, Vikhroli West, Mumbai - 400 079.  
Ph: +91 22 25181900, Fax: +91 22 25181930, Email: r.mahendra@dynalogindia.com
- M/s Theta Controls, 1, Electronic Estate, Satara Road, Pune - 411 009.  
Ph: +91 20 24222556, Fax: +91 20 24222553, Email: sales@thetacontrol.com
- M/s Hi-Tech Robotics Pvt Ltd, Plot No. 136, Pace City -1, Sec-37, Gurgaon - 122001.  
Ph: +91(124)4715300, Fax:- +91(124)4715398, Email:- marketing@hitechroboticsystemz.com



2.33

## Surveillance ROV - Daksh Scout

Daksh Scout – Surveillance ROV is a small unmanned vehicle or robot which provides valuable visual input to the fighting forces about the location and details of the enemy without being detected during Counter-Terrorist (C/T) and Counter-Insurgency (C/I) operations. It is all weather and capable of being tele-operated in day or night conditions relaying back live video to the operator on the ground.

### Salient Features:

- Range: 200m line of sight
- Climbing capability: 35 degree slope/stair with maximum 165mm riser height
- Weight: < 20 kg
- Speed: speed up to 1.2 kmph on flat surface
- Skid steering: The DAKSH-SCOUT is a tracked vehicle and able to turn at its own axis by skid steering
- Day and Night operation capability
- Endurance: Two hours with rechargeable batteries
- Approx. 650mmX420mmX250mm (LXWXH)



Daksh Scout - Surveillance ROV

### Production Agency:

- M/s Bharat Electronics Ltd, Outer Ring Road, Nagavara, Bangalore – 560 045.  
Ph: +91- 80-25039300, Fax: +91-80-25039211, Email: cmd@bel.co.in
- M/s Theta Controls, 1, Electronic Estate, Satara Road, Pune - 411 009.  
Ph: +91 20 24222556, Fax: +91 20 24222553, Email: sales@thetacontrol.com
- M/s Hi-Tech Robotics Pvt Ltd, Plot No. 136, Pace City -1, Sec-37, Gurgaon - 122001.  
Ph:- +91(124)4715300, Fax:- +91(124)4715398, Email:- marketing@hitechroboticsystemz.com

2.34

# Mobile Autonomous Robotic System (MARS)

Mobile Autonomous Robotic System (MARS) is used to extract and diffuse an Improvised Explosive Devices (IEDs). MARS is an unmanned vehicle with manipulator arm which can reach the location of the suspicious objects and extract the object without any interference of human being. It can plan its own path, stop at the location, scan the complete area for suspicious object and pick it up with the help of its on-board 6DoF intelligent manipulator. The complete operation is autonomously controlled by on-board controllers and the live video feed of the operation can be transmitted to a centralised control station for monitoring. This platform is capable of being operated in day or night conditions.

## Salient Features:

- Manipulator Arm with a reach upto 2.0 m
- The arm has a lifting capability of 15kg at 2m in horizontal position from the center of its base. Permits swivel of arm in horizontal plane up to +/- 90 degree.
- Climbing capability: 12 degree slope.
- Speed up to 5 kmph on flat surface.
- In-built brakes, Camera for detection and classification of object, LIDAR based scanning and Force controlled gripper
- Endurance: 4 hrs
- Approx.2300mmx1300mmx1000mm(LXWXH) (height without manipulator)



Mobile Autonomous Robotic System -MARS

## Production Agency:

- M/s ElectroPneumatics, Pune.
- M/s Nandan GSE, Mumbai.

2.35

## Robot Sentry

The Robot Sentry is an autonomous and steerable four-wheel drive unmanned robot intended for urban outdoor operations on relatively flat terrain. It explores and map the area, while continuously providing a video feedback of its surroundings. The robot utilizes localization sensors for determining its location and pose. It has perception sensors for environment mapping during navigation. The robot communicates with the remote station on a WiFi network. This makes it possible to operate a number of such sentry robots in a multi-agent configuration.

### Salient Features:

- On-board algorithmic capability includes simultaneous localization and mapping (SLAM), path planning, exploration, object detection identification and road detection.
- Perception suite consisting of 3D-LiDAR, monocular and stereo cameras, ultrasonics with on-board compute.
- Payload carrying capacity up to 5 Kg
- Weight: 62 Kg
- Dimensions: 640mm x 504mm x 564mm
- Max speed 7.2 Kmph, Max slope 15 deg



Robot Sentry

### Production Agency:

- M/s Larsen & Toubro Ltd,  
L & T House, Ballard Estate, PO Box - 278, Mumbai - 400 001.  
Ph: +91 22 67525656, Fax: +91 22 67525893, Email: [igrc@larsentoubro.com](mailto:igrc@larsentoubro.com)

2.36

## Portable Handheld & Backpack Water Mist based Fire Fighting System

A portable handheld & backpack water mist system is very useful and effective first hand fire fighting equipment. The system can be used for Class A & B fires and also for live electrical fires. The twin fluids water & air under pressure at 15 bar are mixed in the gun to produce water mist. The gun accelerates the water mist to achieve the lancing distance of 12-15 meters for safe operations during the fire fighting. 2-3% foam solution is also added in water to improve the fire fighting performance of the system for flammable liquids.

### Salient Features:

- Working Pressure: 15 bar
- Water Capacity : 9L
- Compressed air bottle 2/4.7/6.8 L ( 200/300 bar)
- Lancing Distance: 12-15 m
- Weight of the system ~ 25 kg
- Fire rating conformance 55 A & 233 B and live Electrical as per EN 3-7 :2004



Portable Handheld & Backpack Water Mist based Fire Fighting System

### Production Agency:

- M/s Aska Equipment Pvt. Ltd,  
R-482, New Rajendra Nagar, Sir Ganga Ram Hospital, Square Shankar Road, Delhi.  
Ph: +91 11 49458800, Fax: +91 11 49458844, Email: info@askagroup.com

2.37

## Explosive Identifier (e-Discerner)

e-Discerner is laser based hand held stand – off explosive identifier to identify explosives in form of liquid, solid and powder contained in transparent/ semi-transparent containers. It provides fingerprint of explosive materials with automatic acquisition of data of different explosive materials which are stored in computer library.

### Salient Features:

- Non-contact detection with stand-off range from 30cm to 5m
- In-situ method and no sample preparation required
- Online identification and declaration of explosives/Explosive derivatives/Mixtures of explosives in less than 12sec
- Easily expandable library
- No warm up time & no interval between two measurements
- Screening of more than 100 explosives in 1 hour



Explosive Identifier (e-Discerner)

### Production Agency:

- M/s. New Age Instruments & Materials Pvt. Ltd,  
13-15, 2nd Floor, Apna Enclave Shopping,  
Complex, Railway Road, Gurgaon, Haryana-122001.
- M/s. AnanthTechnologies Ltd,  
Ananth Info Park, Plot No 39, Hitech City, Phasell, Madhapur, Hyderabad-500081.  
Ph: +91 40 2354 4894, Fax: +91 40 6615 6531, Email: mail@ananthtech.com
- M/s. System Controls Technology Solutions Pvt. Ltd,  
119, 3rd Main, East of NGEF Layout, Outer Ring Road, Kasturi Nagar, Bengaluru-560043.



2.38

## Multi – Mode Hand Grenade

Multi Mode hand grenade can be used in two modes i.e. Offensive mode and Defensive mode depending upon the tactical requirement. The two modes can be changed easily from one to another by removing/ applying fragmenting sleeve. This grenade has cutting edge technologies like modular design of fuze and main body, additional thrower safety of more than 0.5s by innovative safety mechanism. anti-static plastic body, plastic molded pre-formed fragments for uniform pattern, high reliability.

**Defensive Mode:** This mode is used for defence when thrower is in shelter and enemy is in open field. The lethality area is more in this mode as compared to offensive mode. The lethality radius is 8 to 10 m from point of burst.

**Offensive Mode:** This mode is used when thrower in attacking mode. This mode does not have fragments as fragmenting sleeve is removed in this mode. This is having only stunning effects. The lethality radius is 3 to 5 m from point of burst. This mode can also be used for Low Intensity Conflict applications.

### Salient Features:

- Uniform fragmentation pattern with higher density
- Additional thrower safety (Safety Release Delay Mechanism)
- High reliability (more than 95%)
- Designed delay of 3.5 to 4.5 seconds for detonation after release
- Operational Temperature Range is  $-20^{\circ}$  to  $55^{\circ}$  C
- Storage Temperature Range is  $-50^{\circ}$  to  $75^{\circ}$  C



Multi-Mode Hand Grenade

### Production Agency:

- Ordnance Factory Board,  
10-A, SK Bose Road, Kolkata - 700 001, West Bengal.  
Ph; +91-33-22430472, Fax : +91-33-22482927, Email : sec.ofb@nic.in
- M/s Economics Explosives Ltd,  
11, Zade Layout, Bharat Nagar, Nagpur – 440033.  
Ph: +91-712-2561000, Fax: +91-712-2560202, Email: snn@solargroup.com

2.39

# Parallel Probe Saturation Profiler (PPSP)

Parallel Probe Saturation Profiler wirelessly operated fast measuring probing device for vertical distribution of liquid water content (LWC) and liquid water saturation (LWS) level in porous materials like snow and soil. The LWC (%) and LWS (%) are recorded corresponding to different depth positions with a vertical resolution of up to 5 mm. It is a state-of-the art probe for snow science, remote sensing, soil science, agriculture, hydrology, glaciology, forestry and landslide studies.

## Salient Features:

- Probing depth: 2.0 m
- Depth resolution: 5mm
- Time resolution: 2 s
- Accuracy (%) in LWC: + 4%
- Accuracy (%) in LWS: + 6%
- Operating temperature: +80 °C to -15 °C
- Operating Force/Hardness limit: 52 N
- Operation: Manual and remotely operated
- Data Communication: 2.4GHz Zigbee
- Memory storage: 1GB (in hand held device) and 4MB in main unit

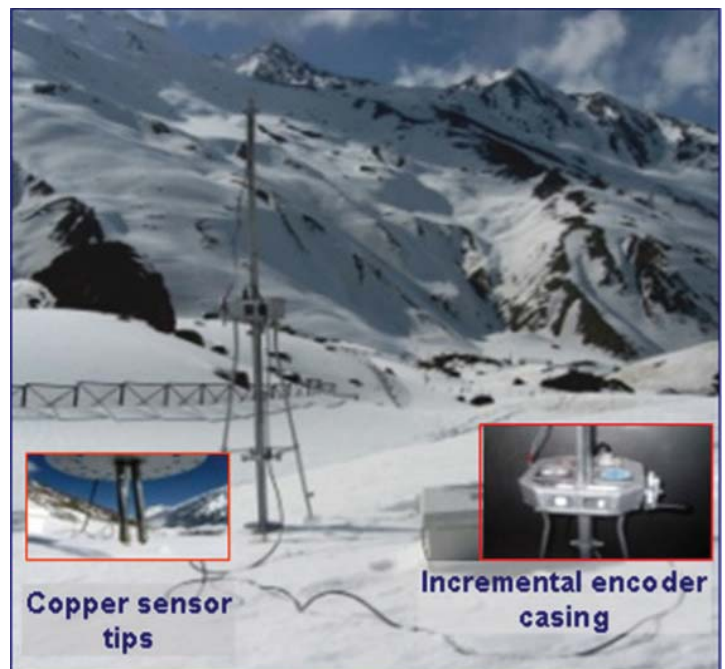

Parallel Probe Saturation Profiler

## Production Agency:

- M/s RAD Technology,  
SCO 546, Level III, Sector 70,  
Mohali – 160071, Punjab.

2.40

## Multi-Parameter Probe (MPP)

Multi-Parameter Probe provides the profile of the hardness and temperature variations within the snowpack. It is very useful in studying the variations of hardness and temperature with respect to depth. It provides information on weak layers which cause release of the avalanches.

### Salient Features:

- Snow types : From new snow ( $50 \text{ kg m}^3$ ) to very dense snow occurring on ski race track ( $500 \text{ Kg m}^3$ )
- Measurement Step : At every 0.1mm
- Force Measurement Range : 0 to +500N
- Temperature Measurement Range :  $-50 \text{ }^\circ\text{C}$  to  $+50 \text{ }^\circ\text{C}$
- Penetration Velocity : From 1 - 20 mm/s
- Snow data logger storage : 4 MB, Can store maximum 111 full Length (1700 mm) measurement data



Multi-Parameter Probe

### Production Agency:

- CSIO, Sector-30, Chandigarh.

2.41

## Snow Moisture Meter (SMM)

SMM provides the liquid water content of snow. It measures volumetric content at particular location. It also provides information on snow density. The information is used for snow avalanche prediction.

### Salient Features:

- Resonant frequency measurement range : 500 - 950 MHz
- Liquid water content measurement range (wetness) : 0 to 15% Volumetric
- Snow density measurement range : 0 to 0.6 g/ cm<sup>3</sup>
- Data logger storage : 4 MB NVRAM
- Operating temperature range : -20 °C to +50 °C
- Power supply : 12V, 6.5 Ah
- Data transmission : RS -232



Snow Moisture Meter

### Production Agency:

- CSIO, Sector-30, Chandigarh.



# Chapter - 3



## Electronics & Communication Systems



3.1

## 3D Medium Range Surveillance Radar

3D Medium Range Surveillance Radar is a ground based mechanically scanning Pulse Doppler radar for air space surveillance to detect and track air targets with reliability, even under hostile EW operational environment. The flexible architecture is a reliable and adaptable technology for multiple applications - early warning for air defence weapon system, air defence sensor at airbases. The radar has advanced technologies like digital receiver, programmable signal processor providing high resolution, accuracy, response and information availability. The radar, packaged on two vehicles, is easy to operate, transportable by air, rail and road.

### Salient Features:

- Medium range 3D surveillance
- Range - 180 km
- Integrated IFF with co-mounted antenna
- Clutter / Weather / ECM video maps
- Jamming analysis and presentation
- Cross country mobility
- High altitude deployability
- Transportable by Road, Air and Rail
- COTS hardware for maintainability and cost effective surveillance solution
- Two vehicles & single vehicle configuration are available
- Can be deployed and decamped in less than 30 min



3D Medium Range Surveillance Radar

### Production Agency:

- M/s Bharat Electronics Ltd,  
Outer Ring Road, Nagavara, Bangalore – 560 045.  
Ph: +91- 80-25039300 Fax: +91-80-25039211, Email: cmd@bel.co.in

3.2

## 3D Surveillance Radar- Revathi

3D Surveillance Radar-Revathi is a ship borne Radar. The radar has advanced technologies like digital receiver, programmable signal processor providing high resolution, accuracy, response and information availability. The radar can auto track up to 150 targets including tracking with IFF. The radar simultaneously forms multiple beams in reception which are used for estimating height. The radar has excellent ECCM features. The antenna of the radar is hydraulically stabilized. The radar incorporates interfaces with Ships Household Data (Gyro, Log, GPS etc) with Combat Management Systems (CMS) onboard.

### Salient Features:

- Medium range 3D surveillance
- Range - 210 km
- Integrated IFF with co-mounted antenna
- Clutter / Weather / ECM video maps
- Jamming analysis and presentation
- COTS hardware for maintainability and cost effective surveillance solution



3D Surveillance Radar - Revathi

### Production Agency:

- M/s Bharat Electronics Ltd,  
Outer Ring Road, Nagavara, Bangalore – 560 045.  
Ph: +91- 80-25039300 Fax: +91-80-25039211, Email: cmd@bel.co.in

3.3

## 3D Low Level Light Weight Radar: Aslesha Radar

3D Low Level Light Weight Radar (3D LLLWR) is a multi-beam ground based 3D Surveillance Radar for deployment in diverse terrains like plains, deserts, mountain tops and high altitude regions. This radar detects and tracks heterogeneous air targets, including helicopters, fighters and UAVs at low and medium altitudes. This semi-distributed active aperture radar uses advanced VLSI and high-speed digital technologies like high efficiency TRMs, DDS, digital receiver and programmable signal processor to provide 3D air space awareness with high accuracy, resolution and reliability.

### Salient Features:

- 3D surveillance for aerial targets at low and medium altitude
- Range - 50 km
- Detection and tracking of fighter aircraft, helicopters, slow moving micro-light aircraft and UAVs
- Track while scan capability
- Full 3D capability using multi-beam technology
- Integrated IFF and side lobe blanking
- Extensive BIT
- Easy transportation by men, light vehicles and under-slung by helicopter
- Fast and Easy to install and decamp
- Remote operation and display through Commander Display Unit



3D Low Level Light Weight Radar: Aslesha Radar

### Production Agency:

- M/s Bharat Electronics Ltd,  
Outer Ring Road, Nagavara, Bangalore – 560 045.  
Ph: +91- 80-25039300, Fax: +91-80-25039211, Email: cmd@bel.co.in

3.4

## 2D Low Level Light Weight Radar

2D Low Level Light Weight Radar (2D LLLWR) is a light weight battery powered compact sensor which provides 2D surveillance in mountainous terrain against hostile aerial targets like UAVs, RPVs, helicopters and fixed wing aircraft flying at low and medium altitudes. It will act as an early warner to air defence weapon systems employed to provide protection to vulnerable areas or vulnerable points. The radar detects and tracks short-range with a high probability of detection. The radar has an integrated IFF that can detect, confirm, classify and attain IFF status on every target in the battle space under surveillance. The radar has an integral GPS and it supports display tracks over tactical map overlay.

### Salient Features:

- 2D Surveillance of aerial targets flying at low and medium altitudes
- Range - 50 km
- Target designation and distribution to Weapon Sites and Command Centre
- Track while scan capability
- Solid state transmitter
- Easy transportation by men, animals and under-slung by helicopter
- Modular for quick setup
- Remote operation and radar display through the Commander Display Unit

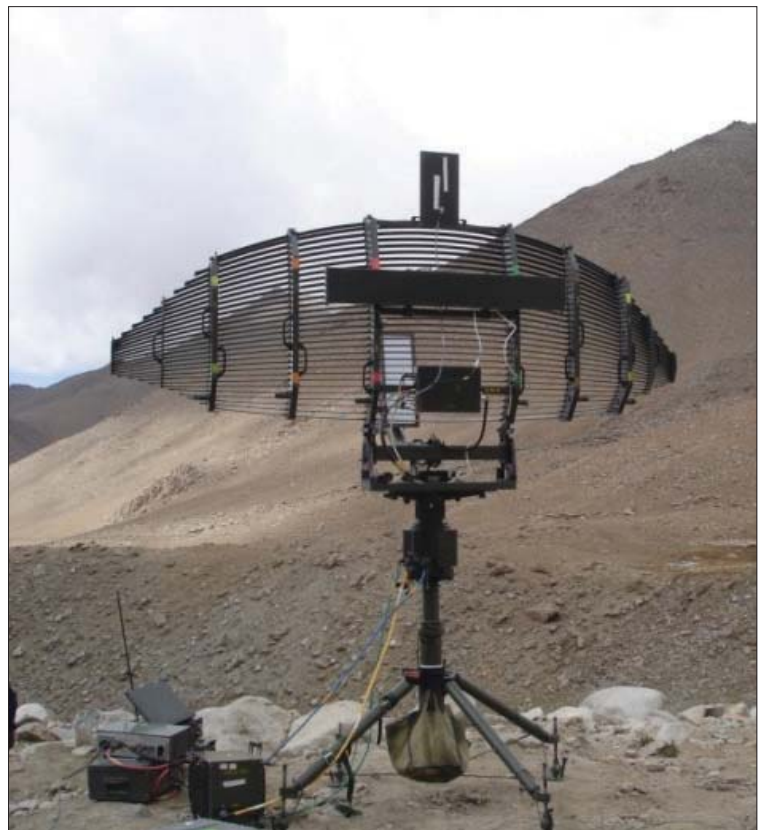

2D Low Level Light Weight Radar

### Production Agency:

- M/s Bharat Electronics Ltd,  
Outer Ring Road, Nagavara, Bangalore – 560 045.  
Ph: +91- 80-25039300, Fax: +91-80-25039211, Email: cmd@bel.co.in



3.5

## 3D Tactical Control Radar

3D Tactical Control Radar (3D TCR) is a stand-alone medium range all weather 3D Surveillance Radar for detection and identification of aerial targets, transmission of pertinent data to Target Data Receiver (TDR). The Radar is capable of Track While Scan (TWS) of airborne targets. The radar has advanced technologies like digital receiver, programmable signal processor providing high resolution, accuracy, response and information availability.

### Salient Features:

- 3D Surveillance Radar for tactical control
- Range - 120 km
- Medium range high resolution 3D surveillance
- Integrated IFF with co-mounted antenna
- Cross country mobility
- Clutter, Weather, ECM video maps
- Jamming analysis and presentation
- High altitude deployability
- Transportable by Road, Air and Rail
- COTS hardware for maintainability and cost effective surveillance solution



3D Tactical Control Radar

### Production Agency:

- M/s Bharat Electronics Ltd,  
Outer Ring Road, Nagavara, Bangalore – 560 045.  
Ph: +91- 80-25039300, Fax: +91-80-25039211, Email: cmd@bel.co.in



3.6

# Surface Surveillance Radar

Surface Surveillance Radar (SSR) is X band 2D radar that enables all round search, detection, automatic tracking, determination of coordinates and motion parameters of surface targets, including 'over the horizon surface' targets. The radar has five modes of operation to cater for various kinds of requirements, which includes surface target detection and tracking: long and short range detection of small to large RCS targets: and aerial target surveillance and tracking.

## Salient Features:

- X-band 2D Radar
- Range - 20 km
- Five modes of operation
- Withstands with ship's pitch and Roll
- Capable of interface with weapon and sensor suite of ship

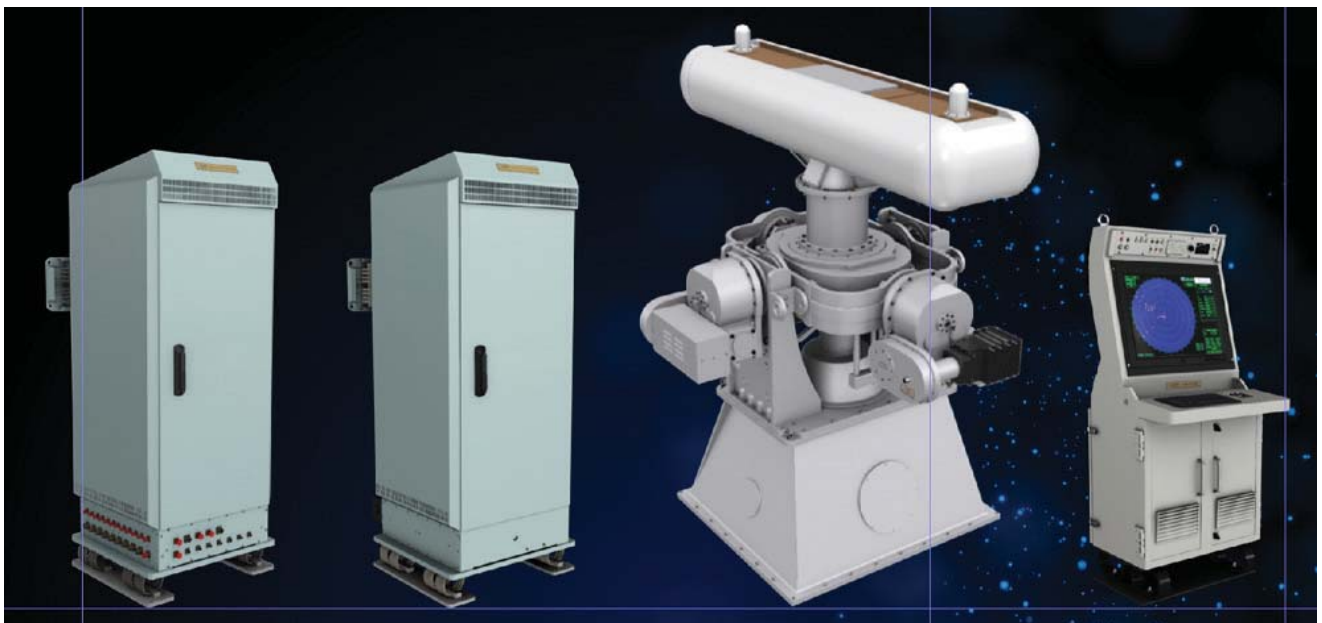

Surface Surveillance Radar

## Production Agency:

- M/s Bharat Electronics Ltd,  
Outer Ring Road, Nagavara, Bangalore – 560 045.  
Ph: +91- 80-25039300, Fax: +91-80-25039211, Email: cmd@bel.co.in

3.7

# Battle Field Surveillance Radar-Short Range (BFSR- SR)

BFSR-SR is a man portable, battery operated Surveillance Radar. The radar has been developed for deployment in the forward areas with the capabilities to detect, track and classify variety of moving ground surface targets. BFSR-SR is a reliable sensor for day and night operations in all weather conditions. The radar is a simple, easy to use and user-friendly surveillance e-sensor. It can be installed and effectively put to use within 5 minutes. Audio and visual aids help identify and classify a target decisively. The radar is also a potential ground based e-sensor for Border Security Force, Coast Guard and Police for surveillance of designated areas.

## Salient Features:

- Light weight, man-portable Pulse Doppler Radar
- Range - 14 km
- Digitally coded waveforms with choice of RF channels
- Presentation of ground clutter map/geographical map in PPI format
- Ability to detect, track and classify
  - Crawling man
  - Single/group of walking men
  - Moving Light and Combat Vehicles
  - Low flying helicopters
- Audio alarm on new target detection over fenced area
- Audio Doppler through head phone/built-in speaker



Battle Field Surveillance Radar

## Production Agency:

- M/s Bharat Electronics Ltd,  
Outer Ring Road, Nagavara, Bangalore – 560 045.  
Ph: +91- 80-25039300, Fax: +91-80-25039211, Email: cmd@bel.co.in

3.8

# Multi Function Fire Control Radar

Multi Function Electronically Scanned Phased Array Radar is the Primary sensor at the Flight level for Air Defence Weapon System. It has the capability to perform extensive search, track multiple targets and missiles, and to command and guide own multiple missiles concurrently. It is engineered to support Weapon System deployment either in group or autonomous configuration. The radar has built-in UHF communication component providing voice and data communication when deployed in a group. Also, Integrated Radio Line Modern (IRLM) provides data communication to the launchers.

## Salient Features:

- Primary Sensor for Air Defence Weapon System
- Range - 80 km
- Multi-Function Electronically Scanned Phased Array Radar
- Automatic target identification
- Variable track update rates
- Low Side Lobe Antenna
- Frequency Agility
- Pulse Compression
- Local and Remote BITE facility
- Automatic threat evaluation and weapon assignment
- Target Engagement and Kill Assessment
- Online status monitoring and data logging
- Remote display
- Variants are available in either HMT or trailer configuration



Multi Function Fire Control Radar

## Production Agency:

- M/s Bharat Electronics Ltd,  
Outer Ring Road, Nagavara, Bangalore – 560 045.  
Ph: +91- 80-25039300, Fax: +91-80-25039211, Email: cmd@bel.co.in

3.9

# Weapon Locating Radar

Weapon Locating Radar (WLR) is electronically scanned phased array radar. The radar automatically locates hostile artillery, mortars and rocket launchers and tracks friendly fire to locate the impact point of friendly artillery fire to issue necessary corrections. The radar is designed to detect projectiles with small cross section across the battle space horizon, and has the capability to handle simultaneous fire from weapons deployed at multiple locations. The radar has advanced technologies like digital receiver, programmable signal processor and uses advanced signal processing techniques for detection and tracking projectiles in the presence of ground, weather clutter and other forms of interference in EW scenario.

## Salient Features:

- Locates hostile artillery, mortars and rocket launchers
- Range - 30 km
- Slewable Phased Array Antenna
- Mono pulse tracking with Pulse Compression
- Adaptive Radar resource scheduling
- Weapon location in high density fire environment
- Tracking and weapon location using advanced algorithms
- Automatic height correction using digital map
- High mobility, quick deployment and decamp



Weapon Locating Radar

## Production Agency:

- M/s Bharat Electronics Ltd,  
Outer Ring Road, Nagavara, Bangalore – 560 045.  
Ph: +91- 80-25039300, Fax: +91-80-25039211, Email: cmd@bel.co.in



3.10

# Border Surveillance System (BOSS)

Border Surveillance System (BOSS) provides all weather surveillance for day/night monitoring of Border areas. It consists of Battle Field Surveillance Radar (BFSR) and Electro-Optical (EO) sensors (Day/ night cameras, eye-safe LRF and geo location sensors) mounted on the Pan-Tilt platform powered with renewable energy source.

## Salient Features:

- Automatic Motion detection
- Remote operation capability :20 km (wired & wireless)
- On-site recording (14 Days)
- Networkable
- Equipped with Hybrid power source (15 days backup)



Border Surveillance System

## Production Agency:

- M/s Bharat Electronics Ltd,  
Outer Ring Road, Nagavara, Bangalore – 560 045.  
Ph: +91- 80-25039300, Fax: +91-80-25039211, Email: cmd@bel.co.in



3.11

## Advanced Driver Night Sight (A-DNS)

A-DNS comprises of an advanced uncooled Thermal Imager and a day camera having low light level imaging capability. It incorporates electronic image fusion of TI and Day camera. It provides tank driver the capability to drive tank in dark with headlights switched OFF. Driver can select TI or Day camera or Fused image (TI + Day Camera) on display.

### Salient Features:

- Form fit configuration for AFVs
- Fused mode allows viewing of thermal image and LED/Beacon lights in the same image during night enhanced visibility



Advanced Driver Night Sight

### Production Agency:

- Ordnance Factory Board,  
10-A, SK Bose Road, Kolkata - 700 001, West Bengal.  
Ph: +91-33-22430472, Fax : +91-33-22482927, Email : sec.ofb@nic.in
- M/s Bharat Electronics Ltd,  
Outer Ring Road, Nagavara, Bangalore – 560 045.  
Ph: +91- 80-25039300, Fax: +91-80-25039211, Email: cmd@bel.co.in

3.12

## Hand Held Thermal Imager with Laser Range Finder (HHTI with LRF)

HHTI with LRF is a cooled TI based integrated day/ night sight with inbuilt eye safe laser range finder, digital magnetic compass, colour CCD and GPS. It is capable of giving range, azimuth and elevation and coordinates of the target. It is used for surveillance, acquisition and speedy & effective engagement of targets by the soldiers.

### Salient Features:

- Integrated Multi function Sight with TI Range: 3 Km for NATO Target
- ELRF: 8 Km for NATO Target (Resolution 5m)
- Day TV: Color
- DMC: 1° accuracy
- Battery operated



Hand Held Thermal Imager with Laser Range Finder

### Production Agency:

- M/s Bharat Electronics Ltd,  
Outer Ring Road, Nagavara, Bangalore – 560 045.  
Ph: +91- 80-25039300, Fax: +91-80-25039211, Email: cmd@bel.co.in

3.13

## Holographic Sight

It is an electro-optic lighting system for small arms. It works on holographic technology. It is a unit magnification sight having an embedded reticule in a see-through window. This sight is very useful in close-quarter battle, especially in counter-insurgency operations, where speed of operation is very critical.

### Salient Features:

- Weight: 335 gm
- Range: 300 m
- Magnification: 1X
- Window size: 30 mm x 25 mm
- FOV: Practically unlimited both eyes open shooting
- Night Vision Compatible



Holographic Sight

### Production Agency:

- M/s Maharishi Electronics Systems,  
55, Brahmin Mitra Mandal Society, Ellisbridge, Ahmedabad – 380006.  
Ph: +91 79 2658 2850, Fax: +91 79 2658 2849, Email: sales@maharshielelectronicsystems.com
- M/s River Engineering Pvt Ltd,  
Plot No 531-532, Udyog Kendra Extension II, Ecotech-III, Greater Noida-201306.  
Ph: +91-120-6749910, Fax: ++91-120-6749902, Email: info@riverengg.com
- M/s EM Shiamani Engineering Pvt Ltd,  
62B, Bommasandra Industrial Area, Bangaluru - 560099.  
Ph: +91- 80-46268645, Fax: ++91- 80-46268648, Email: info@riverengg.com
- Ordnance Factory Board,  
10-A, SK Bose Road, Kolkata - 700 001, West Bengal.  
Ph; +91-33-22430472, Fax : +91-33-22482927, Email: sec.ofb@nic.in

3.14

## Multi-Purpose Sight

The sight is Fast & Accurate Aiming sight with Circular Reticule with dot. It has inbuilt Laser and IR spot designator. It has the facility for Range estimation to enhance scalability & operational efficiency. The technology involved is Infrared, Laser & Day TV Camera.

### Salient Features:

- Integrated Multi function Sight with TI Range: 3 Km for NATO Target
- ELRF: 8 Km for NATO Target (Resolution 5m)
- Day TV: Color
- DMC: 1° accuracy
- Battery operated

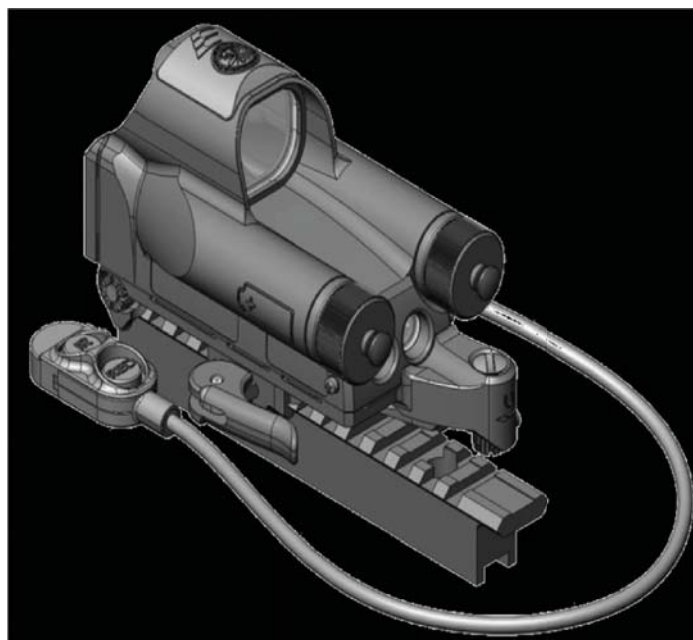

Multi-Purpose Sight

### Production Agency:

- Ordnance Factory Board,  
10-A, SK Bose Road, Kolkata - 700 001, West Bengal.  
Ph: +91-33-22430472, Fax : +91-33-22482927, Email: sec.ofb@nic.in

3.15

## Stabilized Electro-Optical Sight (SEOS)

SEOS is a two axis stabilized panoramic sight having day/night surveillance and tracking capability. The technologies employed are Line of sight stabilization & servo control, Laser, Day TV Camera and Infrared. It is used for surveillance and target tracking of aerial and ground targets with complete Fire control system solution.

### Salient Features:

- Two Axes stabilized Gimbal
- LOS stabilization accuracy: 60  $\mu$ rad
- TI Recognition Range: 4.5 km for NATO Target
- Day TV Recognition Range: 4.5 km for NATO Target
- ELRF Range: 10 Km (with an accuracy of  $\pm 5$ m)
- Automatic Target Tracking



Stabilized Electro-Optical Sight

### Production Agency:

- Ordnance Factory Board,  
10-A, SK Bose Road, Kolkata - 700 001, West Bengal.  
Ph: +91-33-22430472, Fax : +91-33-22482927, Email: sec.ofb@nic.in



3.16

# Stabilized Surveillance Sight (SSS)

The Stabilized Surveillance Sight (SSS) is a standalone, compact miniature sight suitable for multiple platforms surveillance & reconnaissance. The technologies employed are Line of sight stabilization and servo control, Infra Red, Laser, Day TV. It is used for day operation, for surveillance and target tracking of aerial and ground targets.

## Salient Features:

- 2-Axis Stabilized Sight with
- LOS Stabilization Accuracy: 25  $\mu$ rad
- CCD Camera
  - Zoom : Continuous
  - Range : 4.5 Km
- Video Display
- Joy Stick Control



Stabilized Surveillance Sight

## Production Agency:

- Ordnance Factory Board,  
10-A, SK Bose Road, Kolkata - 700 001, West Bengal.  
Ph: +91-33-22430472, Fax : +91-33-22482927, Email: sec.ofb@nic.in

3.17

# VHF Frequency Hopping Radio

Software controlled Frequency Hopping Radio is based on state of the art DSP technology for operation in 30-88 MHz band. It works in Anti-Jam frequency hopping (ECCM), fixed frequency secure and clear modes. This radio has built in high grade digital secrecy and supports both voice and data communication. It incorporates extensive networking features. The radio is useful for Armed Forces, paramilitary forces and police forces. It has specific role for Armoured Fighting Vehicles (AFV) and Truck/ Ground (T/G).

## Salient Features:

- Indigenous secrecy with high crack resistivity in FF-SEC and Anti-Jam (AJ) modes
- User friendly front panel operation
- Selective calling, Scan, Hailing, Squelch and BITE facility
- Interoperability with STARS-V Mk-I & Mk-II
- Supports data communication upto 19.2 kbps
- Automatic Rebroadcast facility
- Remote control operation



VHF Frequency Hopping Radio

## Production Agency:

- M/s Bharat Electronics Ltd,  
Outer Ring Road, Nagavara, Bangalore – 560 045.  
Ph: +91- 80-25039300, Fax: +91-80-25039211, Email: cmd@bel.co.in

3.18

# Advanced VLF Communication System

Very Low Frequency (VLF) is the means of long-range reliable communication from mainland to distributed ships and submerged submarines. Advanced VLF Modulator and Receiver is a solution to this challenge which is able to achieve reliable text data communication up to 400 bps in available 200 Hz bandwidth by use of modern communication signal processing techniques implemented in software on indigenous hardware platform.

## Salient Features:

- Frequency Band – 10-30 kHz
- User Throughput – 400 bps
- Occupied Bandwidth – 200 Hz
- Modulation – GMSK
- FEC – High code rate LDPC
- TEXT compression – Lossless
- Secrecy – Online
- Data Interface – Serial
- User Menu – Display and keypad
- Form Factor – 2U height, 19" rack mountable



Advanced VLF Modulator and Receiver

## Production Agency:

- M/s Bharat Electronics Ltd,  
Outer Ring Road, Nagavara, Bangalore – 560 045.  
Ph: +91- 80-25039300, Fax: +91-80-25039211, Email: cmd@bel.co.in

3.19

# High-Data Rate VLF (HD-VLF) Communication System

HD-VLF Communication System provides secure transmission and reception of data at 800 bps. It comprises of HD-VLF Modulator and HD-VLF Receiver. HD-VLF Modulator has the capability to broadcast secure VLF data in interface with high power VLF transmitter. HD-VLF-HF Receivers are capable of receiving VLF and HF broadcast data.

## Salient Features:

- Frequency Band – 10 kHz to 30 MHz
- User Throughput – up to 800 bps (VLF)
- VLF Modulation – GMSK, MSK, CW, OOK
- HF Modulation – CW, AM, DSB, USB, LSB, ISB
- Online Secrecy



High-Data Rate VLF Communication System

## Production Agency:

- M/s Bharat Electronics Ltd,  
Outer Ring Road, Nagavara, Bangalore – 560 045.  
Ph: +91- 80-25039300; Fax: +91-80-25039211; Email: cmd@bel.co.in

3.20

# Software Defined Radio-Naval Communication (SDR-NC)

SDR-NC is a Multi-mode, Multi Band shipborne Software Defined Radio (SDR) for Naval Communication in 3 to 512 MHz RF band. The SDR has high assurance security architecture and high level software operating environment in line with Software Communication Architecture (SCA) standard. The radio has accessories for remote control operations and security management.

## Salient Features:

- Re-Configurable and upgradable through Software
- SCA 2.2.2
- Integrated secure speech and ECCM enabled data communication integrated HMI



Software Defined Radio - NC

## Production Agency:

- M/s Bharat Electronics Ltd,  
Outer Ring Road, Nagavara, Bangalore – 560 045.  
Ph: +91- 80-25039300; Fax: +91-80-25039211; Email: cmd@bel.co.in



3.21

# Software Defined Radio-Tactical (SDR-TAC)

SDR-TAC provides Ship-to-Coast, Ship-to-Air and Ship-to-Ship communication and network-centric applications in both narrowband and wideband communication in V/UHF and L-Band. The Radio system provides four channel capability. TAC is a 19" rack-mount enclosure designed for rugged and reliable operations to withstand extreme environmental conditions of temperature, humidity, shock and vibration.

## Salient Features:

- RF bands : 30-512 MHz (V/UHF), 960 -1240 MHz (L Band)
- Simultaneous four channel operation
- Mode of Operation : Fixed Freq. & Freq. Hopping
- Integrated secure speech and ECCM enabled Mobile Adhoc Networking (MANET) waveforms
- Data Rate :64 Kbps to 6 Mbps



Software Defined Radio-Tactical

## Production Agency:

- M/s Bharat Electronics Ltd,  
Outer Ring Road, Nagavara, Bangalore – 560 045.  
Ph: +91- 80-25039300; Fax: +91-80-25039211; Email: cmd@bel.co.in

3.22

# Quad Diversity Troposcatter Modem

Quad diversity Tropo-scatter modem provides communication beyond the horizon by using a radio path through the troposphere. The Tropo channel has severe frequency selective fading with time variant deep fades due to varying weather conditions. OFDM based Quad Diversity Modem combats Long/short term fading behavior of Tropo Channel.

## Salient Features:

- Frequency: 1.7 – 2.1 GHz
- Data Rate: Upto 21 Mbps
- Data Interface: L2 Gigabit Ethernet
- Monitoring & Control: SNMP



Quad Diversity Troposcatter Modem

## Production Agency:

- M/s Bharat Electronics Ltd,  
Outer Ring Road, Nagavara, Bangalore – 560 045.  
Ph: +91- 80-25039300; Fax: +91-80-25039211; Email: cmd@bel.co.in

3.23

## Short Range Optical Target Locator (OTL300)-300m

Short Range Optical Target Locator (OTL300), is a Laser based advanced surveillance device. It has additional capabilities of detection of any passive or active optical threats like Sniper sights, Night vision devices, Binoculars, Surveillance cameras, Laser range finders etc., by viewing a strong glint from their front end optics against the background image.

### Salient Features:

- Range : 50-300m
- Field of View : 4-8 deg
- Operation : Day/ Night (Urban)
- Target Marking : Visual + Audio buzzer
- Weight : 1.8 kg (without battery)



Short Range Optical Target Locator (OTL300)

### Production Agency:

- M/s Data Patterns (I) Pvt Ltd,  
No -19, Arya Gowder Road, West Mambalam, Chennai – 600033.  
Phone: +91 44 4741 4000, Fax: +91 44 4741 4444, Email: [datapatterns@datapatterns.co.in](mailto:datapatterns@datapatterns.co.in)

3.24

## Short Range Optical Target Locator (OTL600)-600m

Short Range Optical Target Locator (OTL600) is an advanced surveillance device. It is effective in detection of active and passive optical devices, viz., sniper sights, day sights, NVDs, binoculars, LRFs, laser designators etc., by viewing a strong glint from their front end optics against the background image. OTL600 is an upgrade of OTL300 with increased detection range, connectivity options and advanced features.

### Salient Features:

- Range : 50-600m
- Field of View : 4deg
- Operation : Day/ Night (Urban)
- System Power : Rechargeable Li-ion battery
- Weight : 2 kg (without battery)
- Cartridge type field replaceable battery and also directly with 12V DC
- Onboard memory for video recording up to 24 hrs



Short Range Optical Target Locator (OTL600)

### Production Agency:

- M/s Data Patterns (I) Pvt Ltd,  
No -19, Arya Gowder Road, West Mambalam, Chennai – 600033.  
Phone: +91 44 4741 4000, Fax: +91 44 4741 4444, Email: [datapatterns@datapatterns.co.in](mailto:datapatterns@datapatterns.co.in)

3.25

## Long Range Optical Target Locator (OTL1500)-1500m

Long Range Optical Target Locator (OTL1500) is an advanced surveillance device that employs active imaging for detection of any active or passive optical threat. In addition, it provides target coordinates giving location of the detected optical threat. It is capable of imaging through haze, fog and hence can be effectively deployed for surveillance and optical threat detection in bad weather conditions in day and night.

### Salient Features:

- Range : 100-1500m
- Field of View : 1-3 deg
- Weight : 11.5 kg (without battery)
- Operation : Day/ Night
- System Power : Li ion rechargeable battery



Long Range Optical Target Locator (OTL1500)

### Production Agency:

- M/s Bharat Electronics Ltd,  
Outer Ring Road, Nagavara, Bangalore – 560 045.  
Ph: +91- 80-25039300, Fax: +91-80-25039211, Email: cmd@bel.co.in



3.26

# Laser Dazzler for Crowd Control

Laser Dazzler is a non lethal anti-personnel weapon system for crowd control applications which employs a bright green laser radiation that causes credible glare in subject's eyes leading to temporary functional capability degradation. It has been configured on a light armored vehicle to provide closer and quicker reach towards target. The tripod mounted variant finds application in scenarios which require features like man portability and compactness.

## Salient Features:

- Dazzling Range : 50-250m
- Laser Spot (without scanner) : 1-2m
- Swath Coverage (with scanner) : 8m(Az) x3m(EI)



Laser Dazzler

## Production Agency:

- M/s Bharat Electronics Ltd,  
Outer Ring Road, Nagavara, Bangalore – 560 045.  
Ph: +91- 80-25039300, Fax: +91-80-25039211, Email: cmd@bel.co.in
- M/s Data Patterns (I) Pvt Ltd,  
No -19, Arya Gowder Road, West Mambalam, Chennai – 600033.  
Ph: +91 44 4741 4000, Fax: +91 44 4741 4444, Email: datapatterns@datapatterns.co.in

3.27

## Laser Fence

Laser Fence detects intrusion into secured area. It involves generation of an invisible laser fence with appropriately designed optical transmitters and receivers in the infrared regime. An alarm is generated upon interception of the laser beam anywhere along the entire stretch of the fence. Cameras are integrated with the fence such that on event of intrusion, the video of the scene of the intruded segment is transmitted to the nearest check post/ control room.

### Salient Features:

- Range: Configurable upto 500 m
- Pseudo-random coding with Built in self test (BIST)
- Network compliant with day night operability
- Laser power: upto 3 W @ 808 nm
- Power source: AC mains / DC / Solar
- Visual display and recording
- Coded laser

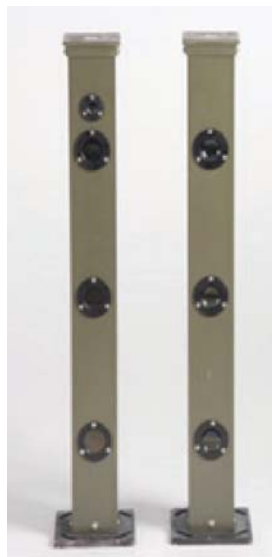

Laser Fence  
Tx & Rx



Camouflaged Laser  
Fence

Laser Fence

### Production Agency:

- M/s Bharat Electronics Ltd,  
Outer Ring Road, Nagavara, Bangalore – 560 045.  
Ph: +91- 80-25039300, Fax: +91-80-25039211, Email: cmd@bel.co.in
- M/s CEL,  
4, Industrial Area, Sahibabad – 201010 (U.P.) Ghaziabad.  
Ph: +91 120-289 5147, Fax: +91 120-289 5142, Email: cel@celsolar.com

# Chapter - 4



## Life Protection Systems

## 4.1

# Bullet Proof Jacket (BPJ)

The Bullet Proof Jacket (BPJ) is light in weight jacket and provides protection against various ammunitions ranging from 9mm carbine to 7.62 mm SLR and AK-47. Its protection consists of Soft Armour Panel (SAP) and (Hard Armour Panel). It provides Back Face Signature (BFS) less than 25 mm at 440 m/s speed of bullet. It has front HAP made out of Ceramics for protection against Hard Steel Core bullets.

### Salient Features:

- Weight (full configuration): 10 kg
- Modular in design
- Consists of three major parts: Soft Armour Panel (SAPs), Hard Armour Panels (HAPs) and carrier to accommodate SAPs and HAPs
- Hard Armour Panel (HAP) provides protection against 7.62 SLR (7.62 × 51 mm, Speed :850 m/s), AK-47(MSC) bullets (7.62 × 39 mm, Velocity: 710±15 m/s ) from 10 meter distance
- Front HAP provides protection against 7.62 SLR, AK-47(MSC) and AK 47 Hard Steel Core Bullets – velocity 720 + 15 m/s, 7.62 X 39mm) bullets.



**Bullet Proof Jacket**

### Production Agency:

- M/s MKU Ltd,  
13, Gandhi Gram, G.T. Road,  
Kanpur - 208007 (UP).  
Ph: +91 512 7102710  
Fax: +91 512 7102727  
Email: protection@mku.com
- M/s SMPP Pvt. Ltd,  
M-17 NDSE Part-II, New Delhi-110049.
- M/s ATMASTCO Ltd,  
Opp. Karuna Hospital, Nandini Road,  
Bhilai, Chhattisgarh-490011.
- M/s Nalin Rubber Private Ltd,  
Plot B-10, Phase 6, Adityapur Industrial Area,  
PO & PS- Gamharia, District Saraikela,  
Kharsawan, Jamshedpur, Jharkhand-83210.

## 4.2

## HAPO Chamber

Rapid ascent of soldiers to an altitude of more than 2700 m is associated with a variety of problems like Acute Mountain Sickness (AMS) & High Altitude Pulmonary Oedema (HAPO). One man HAPO chamber is a portable first aid device that provides emergency treatment for varying degrees of Acute Mountain Sickness including HAPO. It works on the principle of increasing the atmospheric pressure around the patient kept inside the chamber thereby simulating descent from high altitude.

**Salient Features:**

- Can be inflated to a pressure of 130 mm Hg simulating a descent of about 8000 feet
- Portable, light weight bag of double nylon fabric with illumination from inside
- Cold and water resistant having three anti-fog transparent windows
- Automation unit Mk-II is light weight having built in pressure management system and operates using a rechargeable battery



HAPO Chamber

**Production Agency:**

- M/s Sagar Inflatables,  
512 Vyapar Bhavan, 49P Dmello Road, Carnec Bunder, Mumbai – 400009.
- M/s Bengal Waterproof Ltd,  
41, Shakespeare Sarani, Kolkata – 700 017.  
Ph: +91 33 2290160, Fax: +91 33 22901652, Email: debasish@duckback.com
- M/s Raksha Polycoats,  
S-17, T-Block, MIDC, Bhosari, Pune – 411 026.  
Ph: +91 20 27121300, Fax: +91 20 66111655, Email: rakshapolycoats@yahoo.com
- M/s Rajasthan Metal Smelting Co.,  
D-80, Road No.7, VKIA Jaipur- 302 013.



# 4.3

## Reusable Phase Change Material (PCM) Heat packs

PCM heat pack is a reusable pack to provide instant heat to personnel deployed in extreme cold conditions. It works on the principle of storing heat in MetaStable Super Cooled Liquid Phase Change Material (MSCLPCM). It also has therapeutic use in cases like hyperthermia, backache, arthritis, etc.

### Salient Features:

- Triggering device releases heat on demand
- Stable against spontaneous nucleation up to  $\sim -7^{\circ}\text{C}$
- PCM heat packs size 14.5cm x 8.5cm, 20cm x 17cm and 28cm x 20cm provide heating for  $\sim 80, 100$  and 270 minutes at  $-10^{\circ}\text{C}$  ambient temperature
- Neck and chest heating belts provide heating for 130 – 160 min.
- Reusable, economic & rechargeable using hot water ( $80-100^{\circ}\text{C}$ )



Reusable PCM Heat packs

### Production Agency:

- M/s Arihant Enterprise,  
22/156, Arihant, Rajendra Nagar, Near Triveni Building, Borivali East, Mumbai-400066.  
Ph: 022 2870 3071

## 4.4

# Phase Change Material (PCM) Cool Vest

PCM cool vest protect persons from adverse effects of high heat exposure. Coolness stored in PCM is used to absorb excessive body and environmental heat in field conditions. It utilizes latent heat of PCM to provide coolness in field. It reduces sweat loss significantly and stabilizes heart rate, body temperature within safe limit.

### Salient Features:

- Multiple pockets to hold PCM cool packs
- Total weight about 1.5 to 2 kg
- Recharging of PCM packs (for reuse) in 3-4 hours by keeping in deep freezer
- Comfort duration 2-4 hours (depending on environmental temperature)



PCM Cool Vest



PCM Cool pack

### Production Agency:

- M/s Vijay Sabre Safety Pvt. Ltd,  
Plot No 35, Chandivali, Off Saki Vihar Road, Sakinaka, Andheri (E), Mumbai - 400072.  
Ph: +91 22 28475036, Fax: +91 22 28470021, Email: vijaysabre@vsnl.net
- M/s Sure Safety,  
42 A/B, Yoginagar Township,  
Near Zenith Tins, N H No 8, Channi,  
Vadodara, Gujarat-391740.

4.5

## Survival Blanket

Survival Blanket is designed and developed for evacuation of casualties under sub zero temperature condition. It is very efficient in maintaining the body temperature. It has applications in military as well as civilian use such as mountaineering, rescue operations, medial emergencies etc.

### Salient Features:

- It is made of metallised polyester film
- Very light weight
- Less pack volume
- Can be kept in pockets
- Preserves metabolic heat of the body by reflection from the metallised surface



Survival Blanket

### Production Agency:

- M/s Arihant Enterprise,  
22/156, Arihant, Rajendra Nagar, Near Triveni Building, Borivali East, Mumbai-400066.  
Ph: 022 2870 3071

4.6

## Splint Inflatable

Splint Inflatable used in the event of leg injury as first aid measure in extreme cold regions. It immobilizes the leg, therefore, any further injury due to evacuation is prevented. The splint is universal size and has provision to fill air for snug fitting.

### Salient Features:

- Made of rubber coated nylon fabric
- Waterproof
- Zip provides ease of putting on/off
- Provides comforts to the injured leg as the body movement is prevented by air filled in splint



Splint Inflatable

### Production Agency:

- M/s Arihant Enterprise,  
22/156, Arihant, Rajendra Nagar, Near Triveni Building, Borivali East, Mumbai-400066.  
Ph: 022 2870 3071

## 4.7

# All Terrain Water Purification System (WPS)

It is a membrane based, manually powered and portable water purifier suitable for harsh field environment conditions like high altitude deserts and plains. It can be operated in field conditions where the major cause of water contamination is the turbidity due to suspended/ dissolved silt, carbon particles and microbial impurities. The system is equipped with unique antifreeze device for low temperature protection of membrane filters.

### Salient Features:

- Capacity: 12-15 liters per hour
- Working temperature range is 3 °C to 45 °C
- Storage temperature range is -25 °C to 50 °C
- Manually operated light weight pumping (250 grams) system
- Feed water: Turbidity upto 30 NTU, carbon particles & microbial contaminations
- Net system weight is < 4.5 kg



All Terrain Water Purification System

### Production Agency:

- M/s Y&Co, Jodhpur.



4.8

# Chemical Agent Monitor - E-Nasika

E-Nasika Chemical Agent Monitor (CAM) is a handheld Surface Acoustic Wave (SAW) Gas Chromatography (GC) based electronic-nose vapour detector. It is capable of detection of Chemical Warfare Agents (CWA) down to few parts per billion concentration levels within a minute. It has high endurance and high efficiency.

## Salient Features:

- Targeted Compounds: Sarin, Soman, Tabun, VX, Lewisite (Nerve Agents), Sulphur Mustard (Blister Agent), Phosgene (Choking Agent), Hydrogen Cyanide (Blood Agent)
- Sensitivity: Nerve < 7 ppb, Blister < 77 ppb, Blood < 20 ppm, Choking < 5 ppm
- Size: 30 x 10.5 x 12 cm<sup>3</sup>
- Continuous operation: >8 hours
- Weight: 3.1kg with batteries



E-Nasika Chemical Agent Monitor

## Production Agency:

- M/s Bharat Electronics Ltd,  
Outer Ring Road, Nagavara, Bangalore – 560 045.  
Ph: +91- 80-25039300, Fax: +91-80-25039211, Email: cmd@bel.co.in

4.9

## Iron Removal Unit

It is a non electric system which removes excess iron to make water potable.

### Salient Features:

- Structure: Cylindrical; Made of FRP (MK-II)
- Removes iron from 40 ppm to < 0.3 ppm (Desirable WHO/BIS)
- Reduce turbidity to desirable limits
- Filtration rate: 300 L/hr (approx.)
- Size: 4 ft (D) x 7 ft (H). Empty Wt: 110 kg (approx.)
- Shelf Life: 10 Years



Iron Removal Unit

### Production Agency:

- M/s Shrinathji Kayakalp Remedies Pvt. Ltd,  
98 Sector-A, Industrial Area, Mandeep, Dist. Raisen, MP.
- M/s Victor Engineering Co., AT Road, Makun Junction, Dist. Tinsukia, Assam.

4.10

## Flexi Saver Water Purifier

A simple and compact man portable product to provide all-in-one filtration unit for harsh field conditions. It purifies surface contaminated water in to potable water. It is based on membrane which processes water instantly. It is a simple and cost effective unit which needs no electricity and chemicals.

### Salient Features:

- Types of process : Adsorption & Membrane filtration
- Cartridge life : 4000 L (in standard test conditions)
- Capacity: 500 ml (single fill)



Flexi Life Saver Water Purifier

### Production Agency:

- M/s KENT RO Ltd,  
KENT RO Systems Ltd, E 6,7 & 8, Sector-59, Noida 201309, Uttar Pradesh, India.  
Ph: +91-120-3075000, Email : sales@kent.co.in



# Chapter - 5



## Micro Electronics Devices & Computational Systems



5.1

## 120W Pulsed X band Microwave Power Module (MPM)

This is a helix TWT based amplifier working at 9.5 GHz frequency and delivering minimum RF power output of 120 watts and operating with a band width of 1 GHz. This is a natural convection cooled amplifier working at 270 V DC bus.

### Salient Features:

- Power consumption less than 100 Watts
- Operation duty: 10% (Max). Burst Mode Duty: 50%
- Weight: 6.5 kg (Max)
- Dimensions: (Approx.) 13 Inch x 12 Inch x 5 Inch



120W Pulsed X band Microwave Power Module

### Production Agency:

- M/s Bharat Electronics Ltd,  
Outer Ring Road, Nagavara, Bangalore – 560 045.  
Ph: +91- 80-25039300; Fax: +91-80-25039211; Email: cmd@bel.co.in

**5.2**

## 100W CW C-Ku band Microwave Power Module (MPM)

This operates over 6-18 GHz band delivering 100 Watts of RF power. Capable of operating in pulse, CW and burst mode of operation. This gives a minimum gain of 50 dB and gain is shared equally between solid state power amplifier and helix TWT. This is conduction cooled through base plate.

### Salient Features:

- Throughout delay < 70 nsecs
- Prime power: < 550 Watts
- Operates with 270 V dc
- Weight: < 4.5 kg
- Dimensions: (Approx.) 300 mm x 290 mm x 40 mm



100W CW C-Ku band Microwave Power Module

### Production Agency:

- M/s Bharat Electronics Ltd,  
Outer Ring Road, Nagavara, Bangalore – 560 045.  
Ph: +91- 80-25039300; Fax: +91-80-25039211; Email: cmd@bel.co.in

5.3

## 300W Pulsed Ku band TWT

This is a helix TWT in the mini TWT configuration operate at 16.5 GHz over a band width of 2 GHz. This can be used radar applications.

### Salient Features:

- Power consumption: < 400 Watts
- Duty: 20%
- Weight: 500 gm (Max)
- Conduction cooled
- Dimensions: 8 Inch x 1 Inch x 1.5 Inch



300 W pulsed Ku band compact TWT

### Production Agency:

- M/s Bharat Electronics Ltd,  
Outer Ring Road, Nagavara, Bangalore – 560 045.  
Ph: +91- 80-25039300; Fax: +91-80-25039211; Email: cmd@bel.co.in

## 5.4

# Geographical Information system (GIS)

INDIGIS is a suite of GIS components to meet the specific GIS requirements of a collaborative defense environment. This can be customized to build military GIS applications to facilitate planning, execution, monitoring and support of operations. It offers a common platform for display, analysis and decision support involving spatio-temporal data.

## Salient Features:

- Spatial data Interoperability: Support for majority of commonly used map and image data formats and Geo-databases
- Scale space visualization: Retrieval and rendering of spatial data based on Level of Details and view extent
- On the fly projection of map data with map read outs (LLA, ENA, IMGR, GEOREF)
- Seamless integrated visualization and analysis of topographic and hydrographic data
- Integrated tools for military specific requirements like image processing and spatial decision support aids
- Portable Military Symbol Library that caters the military requirements
- Support for Linux and Windows Operating Systems in standalone and integrated mode

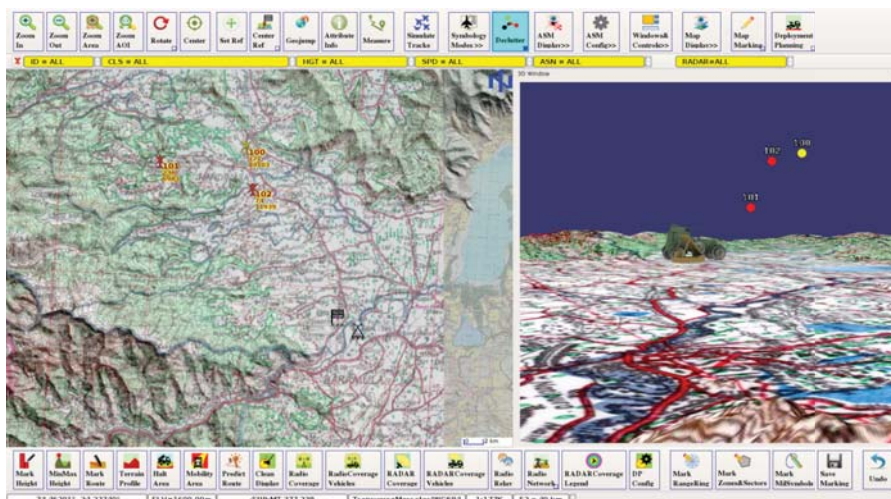

Geographical Information system (INDIGIS)

## Production Agency:

- M/s Bharat Electronics Ltd,  
Outer Ring Road, Nagavara, Bangalore – 560 045.  
Ph: +91- 80-25039300; Fax: +91-80-25039211; Email: cmd@bel.co.in





# Chapter - 6



## Missile Systems

# 6.1

## Surface to Air Missile System - Akash

Akash is a surface to air missile system which provides short range air defence to mobile, semi-mobile and static vulnerable points / areas against multi directional air threats. Weapon system can operate in autonomous or group mode of operation. State of the art real time OS and open system architecture of the weapon system provides fully automatic and network centric operation.

### Salient Features:

- Missile engagement range 3 to 25 km
- Altitude: 3000 mts
- Flight Time: 40 sec
- Warhead Weight: 55 kg
- Self propelled launcher with 03 missiles each
- Simultaneous multiple target engagement with multiple missiles
- Fully powered till intercept using advanced solid integral ramjet technology
- Available on Trailer or High Mobility chassis
- Deployment Altitude: 3000 mts



Akash Missile System

### Production Agency:

- M/s Bharat Dynamics Ltd,  
Kanchan bagh, Hyderabad – 500 058.  
Ph: +91- 40-23456146, Fax: +91-40-23456146, Email: bdbdl@bdl-india.in
- M/s Bharat Electronics Ltd,  
Outer Ring Road, Nagavara, Bangalore – 560 045.  
Ph: +91- 80-25039300 Fax: +91-80-25039211, Email: cmd@bel.co.in

6.2

# Beyond Visual Range (BVR) Air –to–Air Missile - Astra

Astra is an advanced BVR Air-to-Air all weather missile with active Radar terminal guidance. It has excellent ECCM features, smokeless propulsion and very effective in multi-target scenario. It can be launched in autonomous and buddy mode of operation with features for "Lock-On Before Launch" (LOBL) as well as "Lock-On After Launch" (LOAL).

### Salient Features:

- Length : 3838 mm
- Diameter : 178 mm
- Weight : 170 kg
- Launch Range : 100+ km
- Target condition : 9'G' maneuverable target upto 2.5 Mach, from sea level to 20 km altitude



Astra Missile

### Production Agency:

- M/s Bharat Dynamics Ltd,  
Kanchan bagh, Hyderabad – 500 058.  
Ph: +91- 40-23456146, Fax: +91-40-23456146, Email: bdbdl@bdl-india.in



6.3

# Anti Tank Guided Missile - NAG

NAG Missile is a third generation, all weather, fire & forget and Lock-on-Before Launch (LOBL), Anti-Tank Guided Missile (ATGM). It has autonomous IIR seeker. NAG missile is deployed on a tracked vehicle chassis. It has very high accuracy.

Nag Missile Carrier (NAMICA) is BMP2 based Infantry Combat Vehicle (ICV) configured for firing NAG missile. It has independent Commander's Panoramic Sight (CPS) for surveillance, amphibious capability, hunter-killer capability, salvo firing capability and 4 men crew. It can have 06 Nos of ready to fire NAG missile.

## Salient Features:

- Direct & 'Top attack' Capability
- Range: 500 – 4000 Metres
- Capability to defeat all MBTs equipped with composite & reactive armour
- Day and night operation capability
- Single Shot Kill Probability (SSKP) ~ 0.9



NAG Anti Tank Guided Missile



NAG Missile Carrier (NAMICA)



Launch of NAG Anti Tank Guided Missile

## Production Agency:

- M/s Bharat Electronics Ltd,  
Outer Ring Road, Nagavara, Bangalore – 560 045.  
Ph: +91- 80-25039300, Fax: +91-80-25039211, Email: cmd@bel.co.in
- M/s Bharat Dynamics Ltd,  
Kanchan bagh, Hyderabad – 500 058.  
Ph: +91- 40-23456146, Fax: +91-40-23456146, Email: bdbdl@bdl-india.in

6.4

# BRAHMOS Weapon System

BRAHMOS is an all weather, all terrain, precision strike, supersonic cruise missile system for Army, Navy & Air Force. This universal missile can be launched from ships, Mobile Launchers, Submarines and Aircraft. It has network centric architecture, multiple trajectories, way-point capability and is capable of engaging any kind of land or naval targets beyond the horizon in a minimum deployment time.

## Salient Features:

- Land Attack/Anti-ship Capability
- Range: 290 km
- Speed: 2.8 Mach
- High Rate Salvo
- Maximum Shelf Life
- Lowest Life Cycle Cost
- Comprehensive Life Time Support



SU-30 carrying air launched Brahmos



BrahMos launch from a ML



BrahMos Launch from a ship

## Production Agency:

- BrahMos Aerospace,  
16, Cariappa Marg, Kirby Place, Delhi Cantt., New Delhi -110010.  
Ph: +91 11 33123000, Fax: +91 11 25684827, Email: mail@brahmos.com





# Chapter - 7



## Naval Systems

# 7.1

## Hull Mounted Sonar for Surface Ships (HMS-X)

Hull Mounted Sonar for Surface Ships is the Sonar for frigates and destroyers class of ships. The system configuration has a modular system architecture and open standard interfaces, so that variants of the system for each class of naval ship can be configured from the same basic building blocks, without having to start from scratch. The system is supplied with associated auxiliary equipment like (i) NACS, the Near-field Acoustic Characterisation System for calibration of transducers, (ii) Sonar domes, and (iii) Directing Gears for the transducer array.

### Salient Features:

- Range: 20-30 kms
- Simultaneous detection of 4 targets
- Reduced hardware volume
- Software based design and scalable signal conditioning
- Common wideband acoustic transducer array catering to multiple requirements of active sonar and passive sonar



HMS-X Operator Console



HMS-X Array Onboard a destroyer class ship

### Production Agency:

- M/s Bharat Electronics Ltd,  
Outer Ring Road, Nagavara, Bangalore – 560 045.  
Ph: +91- 80-25039300, Fax: +91-80-25039211, Email: cmd@bel.co.in

7.2

# Hull Mounted Torpedo Alert System (HUMTAS-X)

HUMTAS-X is an extension to Hull Mounted Sonars (HMS) on ships to provide Torpedo Alert System for detecting torpedoes. The signal from HMS transducer array is tapped after the pre-amplification of the signal, and the data is independently processed using unique torpedo detection algorithms. It carry out torpedo localization, quick Target Motion Analysis and tracking with accuracy and subsequently it works out escape solutions. The system does not require a dedicated operator rather the HMS operator himself can attend to the alert raised.

## Salient Features:

- Portable and versatile system
- Advanced adaptive beam forming techniques for torpedo detection and tracking
- User-friendly system with excellent built-in FDFL
- Unique algorithms for 'Auto Torpedo Recognition'
- Remote displays available for access to information at multiple locations
- Real-time data recording and online/ offline processing



HUMTAS-X

Operator Console

## Production Agency:

- M/s Bharat Electronics Ltd,  
Outer Ring Road, Nagavara, Bangalore – 560 045.  
Ph: +91- 80-25039300, Fax: +91-80-25039211, Email: cmd@bel.co.in
- M/s. Kerala State Electronics Development Corporation Ltd (Keltron),  
Special Products Group Keltron Equipment Complex, Karakulam ,Trivandrum – 695 564.  
Ph: +91-472-2888999, Fax: +91-472-2888736, Email: cgmkec@keltron.org

# 7.3

## Bow Mounted Sonar for Surface Ships (BMS-X)

Bow Mounted Sonar for Surface Ships is the bow fitted Sonar for frigates and destroyers class of ships. The system configuration has a modular system architecture and open standard interfaces, so that variants of the system for each class of naval ship can be configured from the same basic building blocks. The system is supplied with associated auxiliary equipment like (i) NACS, the Nearfield Acoustic Characterisation System for calibration of transducers, (ii) Sonar domes, and (iii) Directing Gears for the transducer array. It consists of common wide band acoustic transducer array catering to multiple requirements of active sonar and passive sonar.

### Salient Features:

- Range: 20-30 kms
- Simultaneous detection of 4 targets
- Reduced hardware volume
- Software based design and scale



BMS-X: Bow Mounted Sonar for Surface Ships

### Production Agency:

- M/s Bharat Electronics Ltd,  
Outer Ring Road, Nagavara, Bangalore – 560 045.  
Ph: +91- 80-25039300, Fax: +91-80-25039211, Email: cmd@bel.co.in



7.4

## Compact Hull Mounted Sonar for Small Surface Vessels (HMS-X2)

HMS-X2 is a compact hull mounted sonar system. It is an integrated active cum passive sonar, specifically targeted for installation on smaller platforms such as ASW corvettes, coastal surveillance and patrol vessels. It employs advanced adaptive signal and information processing techniques for detection, tracking & classification of targets. A compact MF transducer array, modular front-end signal conditioning hardware and high efficiency switched mode power amplifiers make up the rest of the system.

### Salient Features:

- Simultaneous active and passive modes of operation
- Multiple processing modes
- Automatic tracking of multiple targets
- Built – in simulator and sensor data recorder
- Selectable pulse lengths and range scales



Compact Hull Mounted Sonar HMS-X2

### Production Agency:

- M/s. Kerala State Electronics Development Corporation Ltd (Keltron),  
Special Products Group Keltron Equipment Complex, Karakulam, Trivandrum – 695 564.  
Ph: +91-472-2888999, Fax: +91-472-2888736, Email: cgmkec@keltron.org
- M/s Bharat Electronics Ltd,  
Outer Ring Road, Nagavara, Bangalore – 560 045.  
Ph: +91- 80-25039300, Fax: +91-80-25039211, Email: cmd@bel.co.in

7.5

# Submarine Sonar Suite (SMS-X)

Submarine Sonar Suite is a compendium of multiple sensors for passive detection which collates different characteristics of the same target and provides target data through information fusion. The constituent sonars in the suite include passive sonar, active sonar, intercept sonar, obstacle avoidance sonar and underwater telephony. It is designed for EKM class of submarines.

## Salient Features:

- Easily scalable to suit submarine platforms with varying levels of displacement capacity
- Contact Motion Analysis
- Automatic Torpedo Detection
- End-to-End redundancy for passive sonar systems and improved values of MTBF (Mean Time Before failure)

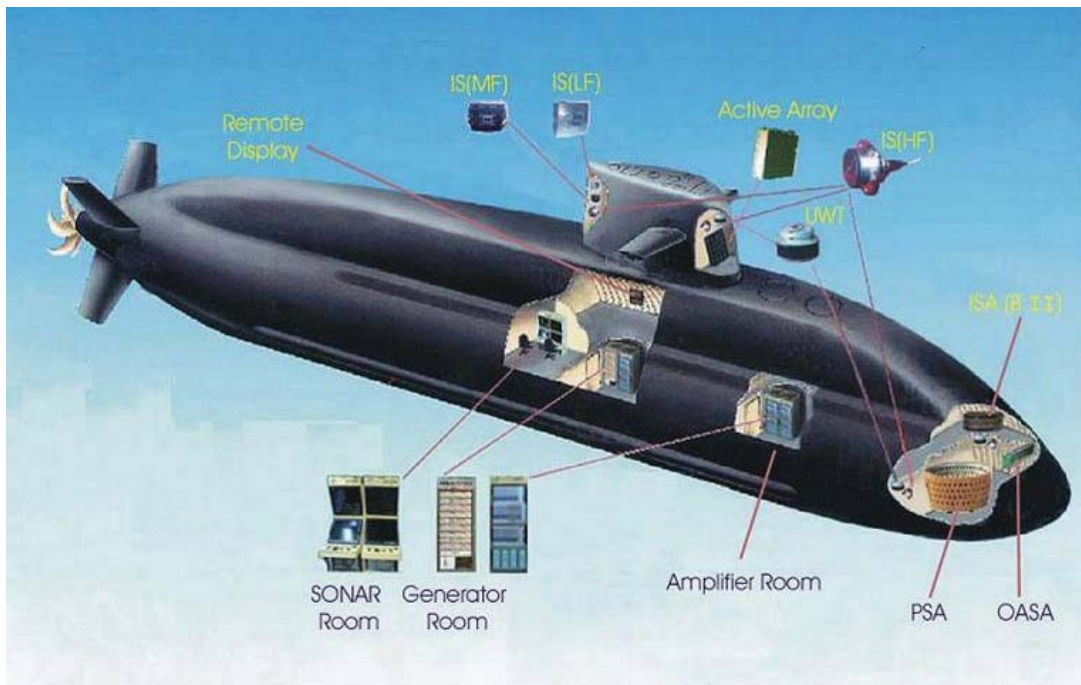

Submarine Sonar Suite SMS-X

## Production Agency:

- M/s Bharat Electronics Ltd,  
Outer Ring Road, Nagavara, Bangalore – 560 045.  
Ph: +91- 80-25039300, Fax: +91-80-25039211, Email: cmd@bel.co.in

7.6

## Rubber Tiles for Submarines

Rubber Tiles developed and fitted on outer hull and fin of submarines have echo reduction and insertion loss properties to reduce transmitted noise and stealth features of vessel. These tiles have advanced acoustic characteristics.

Along with these, epoxy putty has also been developed to fix them on the submarine hull.



Rubber Tiles for Submarines

### Production Agency:

- M/s Indian Rubber Manufacturers Research Association,  
B-88, Road No. 24/U-2, Wagle Industrial Estate, Thane - 400 604.  
Ph: +91 8655095342; Email: director@irmra.org

7.7

# Advanced Torpedo Defence System for Ships (ATDS-X)

Advanced Torpedo Defence System for Ships is a fully integrated system having both torpedo detection and countermeasure capability. The system comprises of two sonars namely a hull mounted sonar and a towed array sonar for passive detection. It is a complete package involving sensors and decoys for defence against vintage as well as modern torpedoes. Acoustic decoying is effected using two types of decoys namely the towed and expendable decoys. The decoys work automatically and choose the appropriate mode of working depending on the incoming signature from the torpedo. The data from the sonar is processed in the Fire Control System (FCS).

## Salient Features:

- Acoustic decoying of the torpedo
- Classification & localisation of torpedo along with target motion parameters
- Intelligent soft kill decoy systems with multi-mode operational capability
- ECS for escape parameters
- Hydraulically operated winch system



Advanced Torpedo Defence System ATDS-X

## Production Agency:

- M/s Bharat Electronics Ltd,  
Outer Ring Road, Nagavara, Bangalore – 560 045.  
Ph: +91- 80-25039300, Fax: +91-80-25039211, Email: cmd@bel.co.in



7.8

## Underwater Acoustic Communication System (UWACS TRITON)

UWACS TRITON is an Underwater Wireless Acoustic Communication System for ships and submarines based on Software Defined Radio architecture. This compact system incorporates advanced modulation and coding techniques in addition to data recording and analysis features. The system offers the user a tuneable wideband communication capability over multiple bands in voice and data communication modes. In addition to the enormous flexibility in operation through a comprehensive GUI. It also supports remote operation and monitoring through standard networking technologies.

### Salient Features:

- Tunable carrier frequency to cater for multiple standards (NATO / EKM)
- OFDM-based high data rate mode and CSK-based robust long range mode
- Pinger, Morse Code, Non Coherent FSK Legacy Operational Modes
- One-way transmission loss ranging
- Option for higher power transmission
- Modular system architecture for easier maintenance and better reliability



Underwater Acoustic Communication System UWACS TRITON

### Production Agency:

- M/s. Kerala State Electronics Development Corporation Ltd (Keltron),  
Special Products Group Keltron Equipment Complex, Karakulam, Trivandrum – 695 564.  
Ph: +91-472-2888999, Fax: +91-472-2888736, Email: cgmkec@keltron.org



7.9

## Low Frequency Dunking Sonar (LFDS-X)

Low Frequency Dunking Sonar is an airborne sonar system which can be deployed from rotary wing platforms, for effectively acting as force multiplier for naval ships. It provides the advantages of lower frequency combined with higher source level for range advantage in littoral ASW. It enables the deployment of sensors to deeper depths for detection of deep dived submarines, thereby substantially enhancing performance. It is an integrated system capable of simultaneously processing inputs from sonobuoys and dunking sonar.

### Salient Features:

- Sonar and Sonics modes of operation
- Light in weight for fitment on 5 ton helicopters
- Encompasses state-of-the-art COTS technology
- Scalable architecture
- Foldable array for higher acoustic aperture
- Capabilities for target detection, localization and classification



Low Frequency Dunking Sonar LFDS-X

### Production Agency:

- M/s Bharat Electronics Ltd,  
Outer Ring Road, Nagavara, Bangalore – 560 045.  
Ph: +91- 80-25039300, Fax: +91-80-25039211, Email: cmd@bel.co.in

7.10

# Emergency Sound Signalling Device for Submarine (ESSD)

ESSD is designed to transmit sonar signals of a pre-designated frequency and pulse shape in an emergency situation for long periods while submerged, so as to attract the attention of passive surveillance sonars of ships or submarines in the vicinity. It consists of a cylindrical assembly outboard the platform, independent hydrostatic pressure tolerant control and monitoring units.

## Salient Features:

- Packaging using hyperbaric pressure vessel
- Fast digital output pressure sensor
- Automatic activation by pressure sensing / cable cut
- Network based control and monitoring
- 'Power over Ethernet' - Single cable for Power and communication
- High-endurance batteries



Emergency Sound Signalling Device

## Production Agency:

- M/s. Kerala State Electronics Development Corporation Ltd (Keltron),  
Special Products Group Keltron Equipment Complex, Karakulam, Trivandrum – 695 564.  
Ph: +91-472-2888999, Fax: +91-472-2888736, Email: cgmkec@keltron.org

7.11

## Own Noise Measurement & Analysis System (ONMA)

ONMA can be fitted onboard any ship or submarine for continuous monitoring and localising the abnormal noise levels of the platform, radiated noise around passive sonar array and for the measurement of cavitation noise. The system consists of onboard sensors (accelerometers) and out board sensors (hydrophones). The system provides real time input for the passive sonar for automatic gain control and noise cancellation. The system is modular in nature and easily scalable to any platform requirement.

### Salient Features:

- Provides real time input for the passive sonar for automatic gain control and noise cancellation
- Modular in nature and easily scalable to any platform requirements

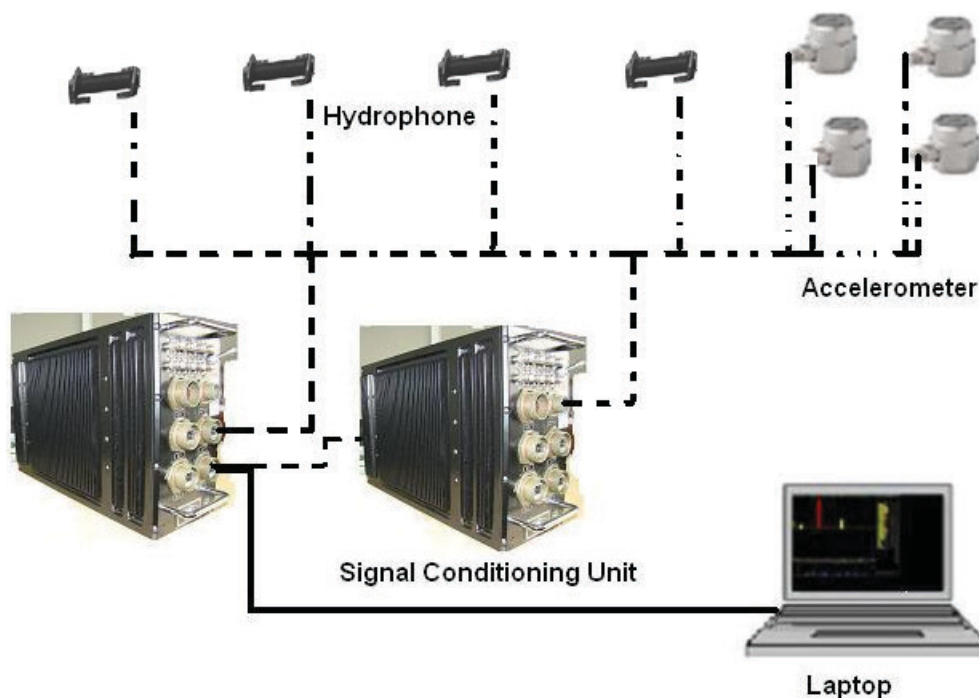

Own Noise Measurement & Analysis System(ONMA)

### Production Agency:

- M/s. Kerala State Electronics Development Corporation Ltd (Keltron),  
Special Products Group Keltron Equipment Complex, Karakulam, Trivandrum – 695 564.  
Ph: +91-472-2888999, Fax: +91-472-2888736, Email: cgmkec@keltron.org

7.12

## Passive Towed Array Sonar for Surface Ships (PTAS-X)

PTAS provides the advantage of towing a large array of hydrophones, with inbuilt provision for instant resolution of target bearing ambiguity. The system consists of a towed sensor array, armoured tow cable, winch and onboard electronics.

PTAS uses the Network Towed Array (NTA), which has an efficient signal telemetry scheme, envisages a modular architecture and reduction in the amount of wiring.

### Salient Features:

- Towed array sensors to track and detect silent submarines
- Excellent signal to noise ratio
- NTA data telemetry with 16 channels
- Digitisation of array information and conversion to Ethernet format



Passive Towed Array Sonar



Networked Towed Array Module

### Production Agency:

- M/s. Kerala State Electronics Development Corporation Ltd (Keltron),  
Special Products Group Keltron Equipment Complex, Karakulam, Trivandrum – 695 564.  
Ph: +91-472-2888999, Fax: +91-472-2888736, Email: cgmkec@keltron.org
- M/s Bharat Electronics Ltd,  
Outer Ring Road, Nagavara, Bangalore – 560 045.  
Ph: +91- 80-25039300, Fax: +91-80-25039211, Email: cmd@bel.co.in
- M/s Larsen & Toubro Ltd,  
L & T House, Ballard Estate, PO Box - 278, Mumbai - 400 001.  
Ph: +91 22 67525656, Fax: +91 22 67525893, Email: igrc@larsentoubro.com

7.13

# Advanced Light Towed Array Sonar (ALTAS-X)

ALTAS-X is variable depth, active cum passive towed array ship sonar system for detection, localization and classification of submarines and torpedoes. It provides early warning of torpedo attack. It consists of a linear towed receiver array and vertical towed projector. It is deployed into the sea with the help of robotic handling gears, on-board electronics and system software for signal processing, display & recording of sonar information.

ALTAS-X has low frequency spectrum of the radiated noise, low losses of propagation and capability to operate at different depths to make best use of the prevailing hydrological conditions.

## Salient Features:

- Capable of operations in shallow and deep waters
- Advanced adaptive beam forming techniques for detection and tracking of silent submarines
- Automatic depth keeping and bottom avoidance functions
- Minimal effect of selfnoise of the platform



Operator Console



Winch & Handling System

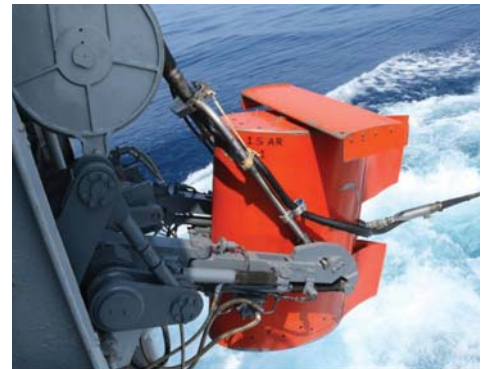

Tow Body Deployment

## Production Agency:

- M/s. Kerala State Electronics Development Corporation Ltd (Keltron),  
Special Products Group Keltron Equipment Complex, Karakulam, Trivandrum – 695 564.  
Ph: +91-472-2888999, Fax: +91-472-2888736, Email: cgmkec@keltron.org
- M/s Bharat Electronics Ltd,  
Outer Ring Road, Nagavara, Bangalore – 560 045.  
Ph: +91- 80-25039300, Fax: +91-80-25039211, Email: cmd@bel.co.in
- M/s Larsen & Toubro Ltd,  
L & T House, Ballard Estate, PO Box - 278, Mumbai - 400 001.  
Ph: +91 22 67525656, Fax: +91 22 67525893, Email: igrc@larsentoubro.com



7.14

## Portable Diver Detection Sonar (PDDS-X)

PDDS-X is a portable sonar system capable of detecting, tracking and classifying potential underwater threats like divers and diver delivery vehicles in shallow waters. The system alerts the operator to confirm the type of threat so that effective countermeasures can be initiated in time. The system can be deployed either outboard a ship or at any location in a harbor, beside a wall, pier or at the sea bottom. The system consists of two parts, an underwater unit and a shore unit, interconnected by water blocked cable carrying data and power supply lines. The underwater unit is a sonar head consisting of transducer arrays, transmitter and front-end receiver electronics hardware. The shore unit consists of the processing and display units, data recorder and power supply.

### Salient Features:

- Detect target information (range and bearing) and target dynamics (speed and course)
- Capable of detecting targets around 360° in azimuthal plane and up to 20° in elevation
- Deployable wet-end unit electronics with associated launch and recovery mechanism
- High probability of detection and low probability of false alarm
- Provides sonar picture in desired format and tactical picture with map overlay



PDDS-X

### Production Agency:

- M/s Bharat Electronics Ltd,  
Outer Ring Road, Nagavara, Bangalore – 560 045.  
Ph: +91- 80-25039300, Fax: +91-80-25039211, Email: cmd@bel.co.in

7.15

# Integrated Coastal Surveillance System (ICSS-X)

ICSS-X is a suite of sensors providing round-the-clock electronic surveillance of the coast line. The sensors include Coastal Surveillance Radar, Electro-Optic Cameras, Indian Automatic Identification System, Diver Detection System, and Communication Target Interception System. Integrated display of targets from each of the sensors is provided on a Common Operating Picture. The target picked up across the sensors is fused and displayed as a single target depending on the position and movement coherence. The system also has a decision support feature which analyses the movement of the target and provide automatic alerts to the operator when suspicious patterns are observed.

## Salient Features:

- Coastal surveillance radar operating in X & S bands
- Daylight and night vision cameras that can track targets against sea wave background
- Unique satellite-based boat tracking system for fitment on small boats
- Capable of providing useful information such as potential fish finding zones, sea weather forecast, cyclone/ tsunami warning, international-border-crossing alert etc. to boatmen while at sea
- Automated rule-based decision support system to identify targets of vulnerability
- System capable of intercepting upward transmission from handsets as well as downward transmission from satellite

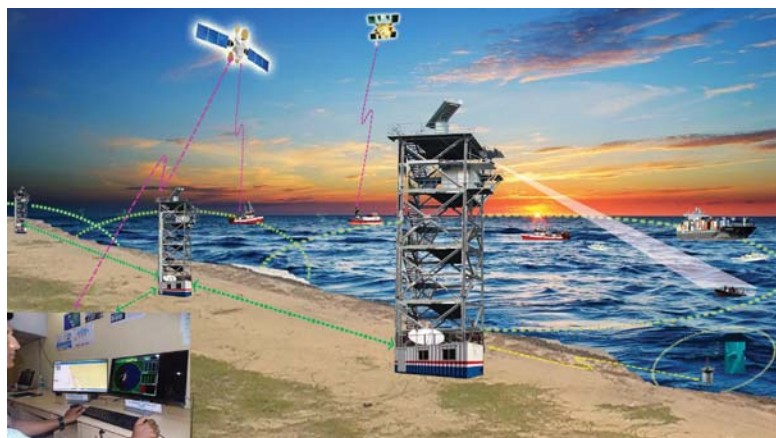

ICSS-X System

## Production Agency:

- M/s Bharat Electronics Ltd,  
Outer Ring Road, Nagavara, Bangalore – 560 045.  
Ph: +91- 80-25039300, Fax: +91-80-25039211, Email: cmd@bel.co.in

# 7.16

## Sonar System Simulators

Sonar Simulator is a vital product for training of the Anti-Submarine Warfare (ASW) crew in sonar operations and maintenance. The set of products in the suite of simulators include:

**(a) e-Bathy:** A training software that would help one to understand how acoustic propagation varies with climatic changes and also influences sonar range prediction.

### Salient Features:

- Provide understanding on sonar performance
- Understanding on role of towed array depth
- Performance prediction of sonar system

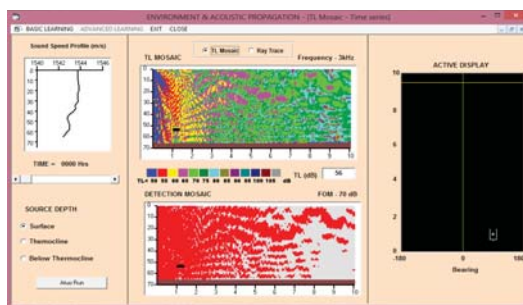

e-Bathy



DHWANI

**(b) DHWANI:** A compact sonar trainer system meant for studying basic sonar operational aspects.

### Salient Features:

- Understanding on basic sonar aspects
- Data acquisition system
- Information on PC
- Projector and Receiver

**(c) Simulator for Ship Sonar (Hull Mounted):** A PC-based generic sonar simulator, for imparting hands-on realistic training on the various functionalities and operational details of hull mounted sonars. This system animates various tactical scenarios in real time.

### Salient Features:

- Animation of various tactical scenarios in real time
- Algorithm to generate near actual signals received by sonar
- Consists of one instructor and multiple trainer stations

- Dual Multi Functional Consoles (DMFCs) for trainees

**(d) Simulator for Ship Sonar (Towed Arrays):** It is a COTS-based training platform designed to train the sonar operators of towed array sonars and torpedo defence systems. Instructor station is designed for selecting various scenarios required for training along with target and environmental parameters.

### Salient Features:

- Consists of Instructor station, Simulation station and Trainee station
- Look & Feel display of sonar of interest
- 3D view of operational area
- Software modules for sensor data simulation, data processing and recording



Ship Sonar Simulator



Submarine Sonar Simulator

**(e) Submarine Sonar Simulator:** A state-of-the-art system, in which training can be imparted in all the modes of operation and maintenance of a submarine sonar suite.

### Salient Features:

- Actual operational scene is simulated
- Considers operational area, environmental parameters, own ship trajectory, targets trajectories, target specific spectral parameters, transmission parameters and machinery regime parameters.
- The sonar simulator generates the sonar output corresponding to the set external scenario and the sonar configuration settings.
- Consists of instructor station, trainee station and simulation station
- Look & Feel display of sonar of interest
- 3D view of operational area
- Software modules for sensor data simulation, data processing and recording

### Production Agency:

- M/s. Kerala State Electronics Development Corporation Ltd (Keltron),  
Special Products Group Keltron Equipment Complex, Karakulam, Trivandrum – 695 564.  
Ph: +91-472-2888999, Fax: +91-472-2888736, Email: cgmkec@keltron.org

7.17

# Heavy Weight Torpedo - Varunastra

Varunastra is ship launched, heavy weight, electrically propelled anti-submarine torpedo. It has high power electric engine powered by on board batteries. It has acoustic homing guidance. It has conformal array transducers for looking wide angles.

### Salient Features:

- Long range with multi-manoeuvering capabilities
- Speed above 40 Kts with electric propulsion
- Acoustic homing with wide look angles capable of tracking silent targets
- Weight: 1500 Kg



Varunastra

### Production Agency:

- M/s Bharat Dynamics Ltd,  
Kanchan bagh, Hyderabad – 500 058.  
Ph: +91- 40-23456146, Fax: +91-40-23456146, Email: bdbdl@bdl-india.in



7.18

## Expendable Decoy - Maareech

Maareech is Expendable Decoy incorporates programmable features to optimize performance for deceiving and seducing incoming torpedoes thus ensuring maximum torpedo engagement time to protect own ship.

### Salient Features:

- Modes of operation: Jammer, Echo repeater, Auto
- Preset depths of operation
- Long endurance and effective range



FCC WDC



Decoy Launcher



Expendable Decoy

### Production Agency:

- M/s Bharat Electronics Ltd,  
Outer Ring Road, Nagavara, Bangalore – 560 045.  
Ph: +91- 80-25039300, Fax: +91-80-25039211, Email: cmd@bel.co.in

7.19

## Torpedo Advanced Light (TAL) – Light Weight Torpedo

Torpedo Advanced Light (TAL) is capable of launch from ships and rotary/fixed-wing aircraft to attack submarines in shallow and deep waters. It performs pre-programmed search patterns, detects the target and homes on to the submarine. It operates in both active and passive modes of operation, and is equipped with digital control and guidance. The guidance system has pursuit and deviated pursuit modes of operation to maximize the hit probability.

### Salient Features:

- High power seawater activated battery
- Operating Depth: 450 m
- Weight (War head version); 220 kg
- Operational range: 19 Km
- Guidance System: Acoustic homing (active/ passive)



Torpedo Advanced Light

### Production Agency:

- M/s Bharat Dynamics Ltd,  
Kanchan bagh, Hyderabad – 500 058.  
Ph: +91- 40-23456146, Fax: +91-40-23456146, Email: bdbdl@bdl-india.in

7.20

## Submarine Fired Decoy – Soft Kill Countermeasure

Submarine Fired Decoy (SFD) is a soft-kill countermeasure designed for protection of own platform from hostile torpedoes. SFD, a slow-sinking type decoy, mimics own platform to confuse and seduce the incoming threat.

### Salient Features:

- Modes of operation: echo repeat, Jammer and mixed
- Long endurance and high depths of operation at maximum submarine speed
- Effective against passive and active homing torpedoes



Submarine Fired Decoy

### Production Agency:

- M/s Bharat Dynamics Ltd,  
Kanchan bagh, Hyderabad – 500 058.  
Ph: +91- 40-23456146, Fax: +91-40-23456146, Email: bdbdl@bdl-india.in

7.21

# Fire Control System (Torpedo)

## Integrated ASW Complex MOD 'C' (IAC MOD 'C')

IAC MOD 'C' is a modular and fault tolerant fire control system with open system architecture and multiple redundancy for all crucial modules / sub systems of the system. It is capable to compute Contact Motion analysis (CMA) for active & passive SONAR targets and RADAR targets using state of the art tracking algorithms.

### Salient Features:

- Designation of multiple targets to attack
- Capable to generate Fire Control solution for all tracked targets within 10 sec
- Generates recommendations on own ship Course and speed to attain the weapon release point at the earliest
- Displays tracks from on-board Sonar systems and track data of on-board radars

## Integrated ASW Complex MOD 'O' (IAC MOD 'O')

IAC MOD-'O' system enhance the capabilities of the platforms by providing features like multi target tracking with latest algorithms, tactical scenario presentation on the display, recommendations to TASWO and facility for adaptation of any new torpedo. It has got interface modules for sensors fit and weapon fit of the platforms

### Salient Features:

- Tracks & displays targets from on-board sonar and two on-board radar
- Acquires & displays ship's house hold data (LOG, GYRO & GPS )
- Calculates Theater Mission Planning System (TMPS) for all targets
- Generates fire control solutions for designated targets for rocket launcher and QTTM



### Production Agency:

- M/s Bharat Electronics Ltd,  
Outer Ring Road, Nagavara, Bangalore – 560 045.  
Ph: +91- 80-25039300, Fax: +91-80-25039211, Email: cmd@bel.co.in

7.22

# Composite Sonar Dome for Naval Ships

Sonar dome is a protective cover for sonar array in warships those having Anti-Submarine Warfare (ASW). The dome is acoustically transparent, structurally rigid and strong to withstand heavy slamming loads.

## Salient Features:

- Material: GFRP (Glass fiber reinforced plastic).
- Thickness 21 mm to 60 mm, Length: 10.5 m, Width & Height: 3 m, Weight: 800 kg.
- Constrained layer damping in window region
- Realized the shell in single shot infusion
- Range of frequency of operation: 2 kHz to 12 kHz



Composite Sonar Dome



## Production Agency:

- M/s Kineco Pvt Ltd,  
Plot No 60, Bardez, Pilerne Industrial Estates, Pilerne, Marra, Goa - 403511.  
Ph: +91 832 6648888; Fax: +91 832 6648889; Email: sales@kinecokamanindia.com



7.23

# Impressed Current Cathodic Protection System (ICCP)

ICCP is used for protection of ship's hull from corrosion in sea water. Systems for both single and two zone impressed current cathodic protection is available. The system consists of auto control unit, reference electrode and anodes. It suppresses corrosion attack on steel hull.

Auto Control Unit (ACU) for ICCP is used for supply and control of DC current to the ICCP anode. It is fully automated, light weight and compact. It has all safety mechanisms in built for high performance and efficiency.

## Salient Features:

- Current rating : 100 A (single zone), 60 A (two zone)
- Number of anodes : Four/zone
- Reference electrode : Zinc or Ag-AgCl
- Type of anode/ref. Electrode : Recessed and protruding
- For use in Underwater steel structures

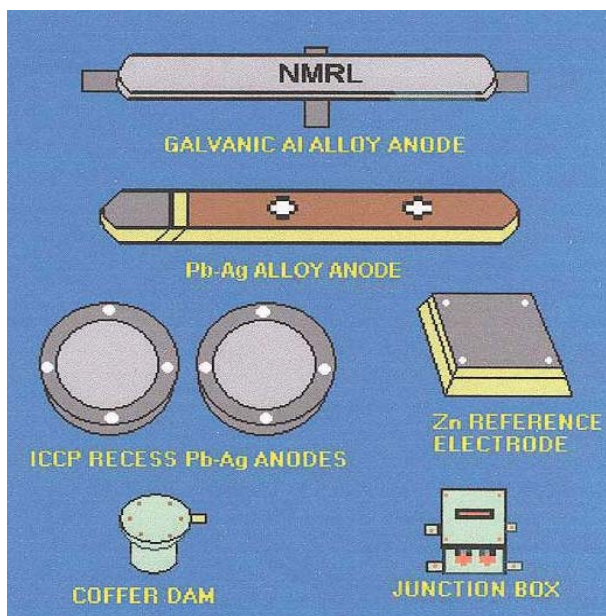

Impressed Current Cathodic Protection System (ICCP)



Advanced Auto Control Unit for ICCP System

## Production Agency:

- M/s Bharat Electronics Ltd,  
Outer Ring Road, Nagavara, Bangalore – 560 045.  
Ph: +91- 80-25039300, Fax: +91-80-25039211, Email: cmd@bel.co.in

7.24

## Submarine Escape Equipment

Submarine Escape Equipment is a self contained closed circuit breathing apparatus used for escape from a damaged submarine from depths upto 100 m and 120 m. The breathing apparatus maintains the partial pressure of oxygen at a given depth to prevent the ill effects of hyperbaric oxygen and other gases. The hydro suit is a positively buoyant protective clothing which helps the submariner to float on the surface after the escape and protects him from cold as well as sea animals.

### Salient Features:

- Breathing apparatus and a protective hydro suit
- Superior water proofing at very high hydrostatic pressure (200 cm)
- Can operate in tropical conditions of 25-50 °C water
- Made of light weight neoprene hypalon coated fabric
- Total endurance of the set is 2.5 hrs

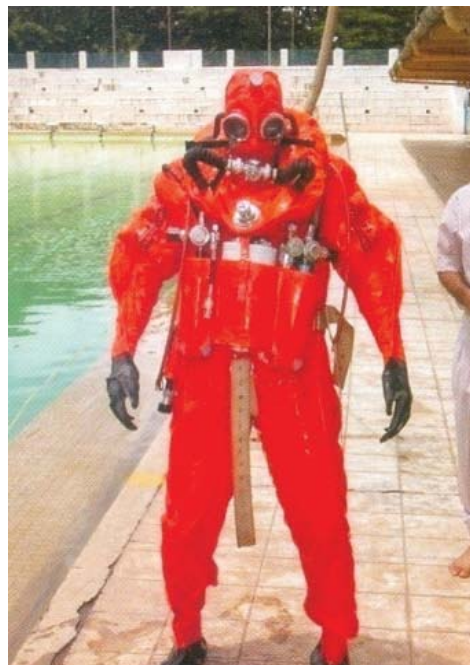

Submarine Escape Equipment

### Production Agency:

- M/s Elite Polymer Ltd,  
Nischindha (W), P.O. Ghoshpara (Bally),  
Howrah 711227, Kolkata.

7.25

## Naval Wargame

It is a tactical level wargame software for Naval Forces. It enables training of naval commanders in real time pertaining to Anti-Surface Warfare, Anti-Air Warfare, Anti-Submarine Warfare, SSK Operations, Air and Maritime-Air Operations, Electronic Warfare and Data Communications. The software supports configuration of virtual consoles of Radar, Sonar and ESM systems. The system can be utilized for training the command teams of ships, submarines and aircrafts in a realistic training scenario and rehearse the application of naval tactical doctrine.

### Salient Features:

- WAN-based multi-venue game playability
- Integrated display of IHO S-63 Electronic Navigational Charts
- Extendable database of Naval Sensors, Weapons, Platforms, Environment, etc
- Supports configuration of new sensor, weapon and platform systems
- Scenario generator for defining scenario comprising of several forces
- Supports Game Controller, Instructor, Force Controller, Platform Commander, Radar Operator, Sonar Operator, ESM Operator and Communication roles.
- Module for Brief and De-brief Facility
- Comprehensive Platform Dynamics Modelling
- Comprehensive Sensor, Weapon, Countermeasure and Communication modelling
- Damage Assessment Modelling

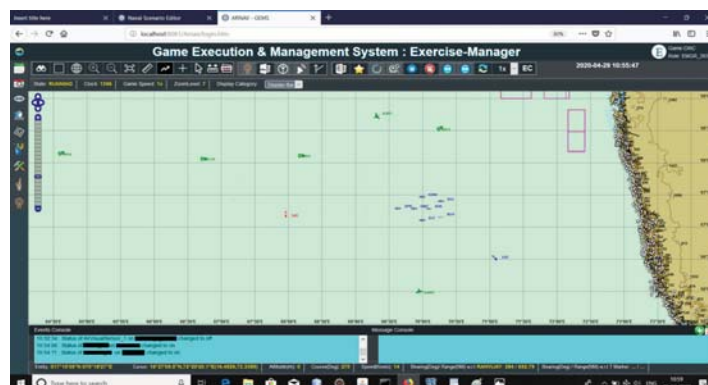

Naval Wargame

### Production Agency:

- DG(SAM), Room No 317, DRDO HQrs,  
Rajaji Marg, New Delhi - 110011.  
Ph: +91-11-23792825, Fax: +91-11-23792946, Email: [dgsam@hqr.drdo.in](mailto:dgsam@hqr.drdo.in)

7.26

## Under Water Acoustic Sensors (Hydrophones)

Under Water Acoustic Sensor is a miniaturized, low cost, light-weight, high sensitivity, Omni-directional Hydrophones in the form of single element and arrays for Naval & Marine Systems applications.

### Salient Features:

- High Receiving Voltage Sensitivity better than  $-170\text{dB}$ , ref  $1\text{V}/\mu\text{Pa}$
- Acoustically transparent polyurethane (PU) packaging
- Works up to 400 mtr. depth/ 40 bar hydrostatic pressure



**Buried Object Scanning SONAR (BOSS) Hydrophones**



**Anti Torpedo Mobile Decoy Hydrophone**

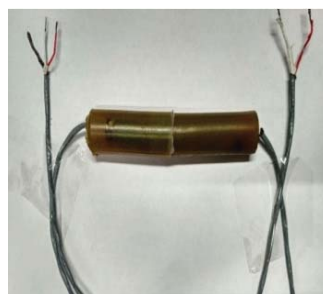

**Thin Line Towed Array (TLTA) Hydrophone**



**Under Water Mines Hydrophone**

### Production Agency:

- M/s Maharishi Electronics Systems,  
55, Brahmin Mitra Mandal Society, Ellisbridge, Ahmedabad – 380006.  
Ph: +91 79 2658 2850, Fax: +91 79 2658 2849, Email: sales@maharshielelectronicsystems.com

7.27

# Air Droppable Container - Sahayak NG

Sahayak NG is an air-droppable container designed for delivery of supplies during emergencies for platforms in distress at sea. Sahayak NG features state-of-the-art GPS system for location identification and incorporates a rechargeable battery for extended uses.

## Salient Features:

- Emergency supplies can be transported
- Two-stage parachute
- Capability to withstand high shock



Sahayak NG- Air Dropable Container

## Production Agency:

- M/s Avantel Ltd,  
Plot No 47/P, APIC Industrial Park,  
Gambheeram (V), Anandapuram (M), Visakhapatnam-531163.



7.28

# Instant Fire Detection and Suppression System (IFDSS)

IFDSS is a microcontroller based automatic fire detection and suppression system that saves crew and vehicle (Infantry combat vehicle) from fire/explosion eventuality. For fire detection, dual spectrum IR detectors are used in crew compartment and linear thermal detector (fire wire) is used in engine compartment. In case of any eventuality of fire in tank the signal from detector is given to designed automatic fire extinguishers through Master Control Unit. In engine compartment, system provides overheat warning through Audio Visual Alarm Unit and actuates the fire extinguishers through MCU in case of fire eventuality.

## Salient Features:

- Fire Detection & suppression time : < 150ms in crew Compartment  
: < 10 s in Engine Compartment
- Environmental tests qualified as per JSS-55555
- EMI/EMC qualified as per MIL-STD-461E



Instant Fire Detection and Suppression System (IFDSS)

## Production Agency:

- M/s Bharat Electronics Ltd,  
Outer Ring Road, Nagavara, Bangalore – 560 045.  
Ph: +91- 80-25039300, Fax: +91-80-25039211, Email: cmd@bel.co.in

# Chapter - 8



NBC

8.1

# NBC Mobile Water Purification System (WPS)

NBC Water Purification System (WPS) purifies Nuclear, Biological & Chemical contaminated & saline, turbid water and provides a potable drinking water. The system is mounted on mobile platform with high purification rate can be deployed for disaster management. It works on reverse osmosis principle.

## Salient Features:

- Capacity: 2000 Litres/hr
- Feed water salinity: 4000 ppm, Turbidity: 50 NTU.
- Captive power source: Diesel Generator Set
- Water analysis kit, First Aid Kit, Pillow type Rubber tanks, Potable Decontamination apparatus, Water Poison Detection kit



NBC Mobile Water Purification System (WPS)

## Production Agency:

- M/s Permionics Membranes Pvt Ltd,  
3/29, 4/19, BIDC, Gorwa Estate, Vadodara-390 016, Gujarat.  
Ph: +91 265 228 0003 228 3171, 228 1563; Fax : +91 265 228 1512  
Email : info@permionics.com

8.2

## NBC Casualty Bag Full

NBC Casualty Bag Full developed to evacuate the effected persons from the contaminated environment. It is made out of flame retardant and water & oil repellent material for the safety of the casualty. It has activated charcoal to prevent any odor.

### Salient Features:

- It is made from
  - Fabric Nylon, Flame retardant, Water & Oil repellent as an outer layer
  - Activated charcoal, coated non-woven fabric as middle layer
  - Cotton fabric as inner layer to prevent contact of carbon with skin
- provided with observation window of LDPE laminated HDPE fabric
- Breathable / air permeable
- Protective bag for transporting casualty from contaminated environment who cannot walk



NBC Casualty Bag Full

### Production Agency:

- M/s Arihant Enterprise,  
22/156, Arihant, Rajendra Nagar, Near Triveni Building, Borivali East, Mumbai-400066.  
Ph: 022 2870 3071

8.3

## NBC Casualty Bag Half

NBC Casualty Bag Half developed to evacuate the effected persons from the contaminated environment. It is only for half of the body. It is made out of flame retardant and water & oil repellent material for the safety of the casualty. It has activated charcoal to prevent any odor.

### Salient Features:

- It is made from
  - Fabric Nylon, Flame retardant, Water & Oil repellent as an outer layer
  - Activated charcoal, coated non-woven fabric as middle layer
  - Cotton fabric as inner layer to prevent contact of carbon with skin
- Provided with observation window of LDPE laminated HDPE fabric
- Breathable / air permeable
- Protective bag for transporting casualty from contaminated environment



NBC Casualty Bag Half

### Production Agency:

- M/s Arihant Enterprise,  
22/156, Arihant, Rajendra Nagar, Near Triveni Building, Borivali East, Mumbai-400066.  
Ph: 022 2870 3071



8.4

## NBC Decontamination Suit

NBC Decontamination Suit is meant for the protection from hazardous toxic environment during NBC/ hazardous chemical decontamination work. It is coverall suit which protects entire body from any contamination. The activated charcoal coating absorbs all hazardous chemical/ gases.

### Salient Features:

- It is made up of rubberised fabric & activated charcoal coated non woven fabric
- After wearing it the individual may move freely and work with the decontamination equipment



NBC Decontamination Suit

### Production Agency:

- M/s Arihant Enterprise,  
22/156, Arihant, Rajendra Nagar, Near Triveni Building, Borivali East, Mumbai-400066.  
Ph: 022 2870 3071

8.5

## Radiation Monitor

It is a mobile station for personal monitoring and rapid screening in the event of a nuclear radiation fallout, radiation release or radiation contamination during nuclear or radiological emergency. It is also used for prevention of illicit movement of radioactive source. It is an automatic and compact device. It has very high accuracy with zero false alarm.

### Salient Features:

- Self-contained, quick and easy set up (Approx. 15 min)
- Lightweight & Modular
- AC as well as battery operated
- Integrated camera for image capturing



Radiation Monitor

### Production Agency:

- M/s PLA Electro Appliances,  
Vidyavihar (West) City, Mumbai – 400 086.  
Ph: +91 22 25116864, Fax: +91 22 25168948, Email: pla@plaelectro.com

8.6

## Water/ Liquid Radioactivity Contamination Monitoring System (WLRCMS)

WLRCMS measures radioactivity present in the Water/ Liquid which have possibility of contamination from radioactivity due to dirty bomb explosion, atomic bomb detection, or any other means such as medical & research application of radiostope. WLRCMS can be employed at site in operations and in disaster management situations.

### Salient Features:

- Portable, field use Instrument, Mounted on trolley
- Mains or Battery Operation
- Real Time, On-Line
- Easy Installation & Calibration
- Monitoring of Gamma Activity with Source Identification
- Fully controlled by Software with Display on rugged device



WLRCMS

### Production Agency:

- M/s Indesys,  
47, Industrial Estate, Nangargaon, Lonavla, Pune.  
Ph: +91 2114 272681, Fax: +91 2114 273465, Email: idsipl@gmail.com

# 8.7

## Food Radioactivity Contamination Monitoring System (FRCMS)

Food Radioactivity Contamination Monitoring System carries out the Radioactivity assessment in food stuff and drinks for managing nuclear and radiological emergencies/ disasters. It is a critical system to save human lives from nuclear contamination in food and drinks. Its operation is quick and easy.

### Salient Features:

- Partable & Dismountable
- Wheel based transport package
- Detection and identification of the radioisotopes in food stuffs & drinks
- Gross Activity Measurement and Isotope Activity Measurement



Food Radioactivity Contamination Monitoring System

### Production Agency:

- M/s Indesys,  
47, Industrial Estate, Nangargaon, Lonavla, Pune.  
Ph: +91 2114 272681, Fax: +91 2114 273465, Email: idsipl@gmail.com

8.8

# Pocket Dosimeter (PDM)

Pocket Dosimeter PDM is a GM Tube and Micro Controller based pocket size battery operated instrument to indicate alternately gamma radiation dose and dose rate with caution alarms. It has wide measurement range and digital display.

## Salient Features:

- SENSOR : Energy Compensated GM Tube
- RANGE : 0.1 R to 999.9 R (Dose)  
0.01 to 999.9 R/h (Dose Rate)
- POWER : 2 x 3.6 Lithium Cell (R6/AA SIZE)
- ALARMS : Audio Warning at 50,75,150 R and for low battery charge
- WEIGHT (SIZE) : 200 gm (96 x 64 x 28 mm)

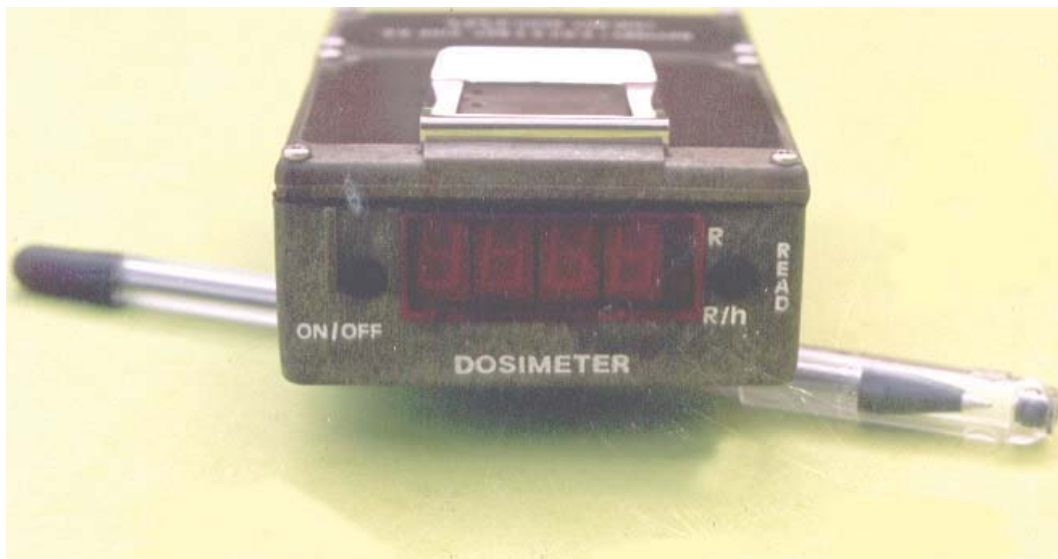

Pocket Dosimeter

## Production Agency:

- M/s PLA Electro Appliances Ltd,  
Thakor Estate, Kurla Kirol Road Vidyavihar (West), Mumbai - 400 086, Maharashtra.  
Ph: +91 22 25116864, Fax: +91 22 25168948, Email: pla@plaelectro.com
- M/s Indesys,  
47, Industrial Estate, Nangargaon, Lonavla, Pune.  
Ph: +91 2114 272681, Fax: +91 2114 273465, Email: idsipl@gmail.com



8.9

## Portable Dose Rate Meter (PDRM)

PDRM is an electronic instrument to measure the dose rate or the exposure level of gamma or x-radiations in a field affected by nuclear warfare. It is a lightweight self-powered portable instrument with long battery life. It has 4 ranges with audio alarm, dial illumination and self-diagnostic facility.

### Salient Features:

- Gamma Radiation Measurement: 10 mR/h – 1000 R/h
- Audio as well as Visual Indications
- Handheld and Light Weight
- EMI/EMC Compliance as per MIL STD 461C/462
- Environmental Specifications as per JSS55555 Standards



Portable Dose Rate Meter

### Production Agency:

- M/s PLA Electro Appliances Ltd,  
Thakor Estate, Kurla Kirol Road Vidyavihar (West), Mumbai - 400 086, Maharashtra.  
Ph: +91 22 25116864, Fax: +91 22 25168948, Email: pla@plaelectro.com
- M/s Indesys,  
47, Industrial Estate, Nangargaon, Lonavla, Pune.  
Ph: +91 2114 272681, Fax: +91 2114 273465, Email: idsipl@gmail.com

8.10

# Roentgenometer

The Roentgenometer is a radiation monitoring equipment for vehicle applications that can measure the gamma radiation level at a place due to nuclear fallout. The detector unit and the measuring units are housed in 2 separate units. These are inter connected to each other through a cable.

## Salient Features:

- SENSOR : GM Tube
- RANGE : 1 mR/h-1000 R/h in four ranges
- DISPLAY : Analog Meter
- POWER : 18- 32 VDC Vehicle Batteries
- MOUNTING : Shock Proof Vehicle Mounting
- WEIGHT : 2.5 kg



Roentgenometer

## Production Agency:

- M/s PLA Electro Appliances Ltd,  
Thakor Estate, Kurla Kirol Road Vidyavihar (West), Mumbai - 400 086, Maharashtra.  
Ph: +91 22 25116864, Fax: +91 22 25168948, Email: pla@plaelectro.com
- M/s Indesys,  
47, Industrial Estate, Nangargaon, Lonavla, Pune.  
Ph: +91 2114 272681, Fax: +91 2114 273465, Email: idsipl@gmail.com

# 8.11

## Radiation Detection Measurement and Control Unit (RADMAC)

RADMAC is a microcontroller based instrument which activates NBC protection system of the tank on receiving the first signature of nuclear explosion, measures fallout gamma radiation dose rate, cumulative dose and provides help to the crew member in different situations of nuclear contamination.

### Salient Features:

- Compatible for Vehicle Mounting and 18-32 V Vehicle Power
- Rugged Construction to meet requirement of Environmental, EMI/EMC and EMP Test Standards for Tracked Vehicle



Radiation Detection Measurement and Control Unit

### Production Agency:

- M/s PLA Electro Appliances Ltd,  
Thakor Estate, Kurla Kirol Road Vidyavihar (West), Mumbai - 400 086, Maharashtra.  
Ph: +91 22 25116864, Fax: +91 22 25168948, Email: pla@plaelectro.com
- M/s Indesys,  
47, Industrial Estate, Nangargaon, Lonavla, Pune.  
Ph: +91 2114 272681, Fax: +91 2114 273465, Email: idsipl@gmail.com

8.12

## Gamma Flash Sensor

The Gamma Flash Sensor detects the pulses of very high gamma radiation level and gives an electrical output which can be used to activate the Automatic NBC Protection System of Armoured vehicles & ICV.

### Salient Features:

- Detects the first signature of Nuclear Detonation
- Uses high speed semiconductor sensor
- Suitable for mounting in Tracked Vehicles
- Rugged construction to meet Military Environment, EMI/EMC and EMP Standards



Gamma Flash Sensor

### Production Agency:

- M/s PLA Electro Appliances Ltd,  
Thakor Estate, Kurla Kirol Road Vidyavihar (West), Mumbai - 400 086, Maharashtra.  
Ph: +91 22 25116864, Fax: +91 22 25168948, Email: pla@plaelectro.com
- M/s Indesys,  
47, Industrial Estate, Nangargaon, Lonavla, Pune.  
Ph: +91 2114 272681, Fax: +91 2114 273465, Email: idsipl@gmail.com



8<sub>13</sub>

## CBRN Mini UGV

The CBRN Mini-Unmanned Ground Vehicle (UGV) is tele-operated vehicle. It is capable of collecting samples with the help of robotic arm. It is capable of stairs climbing, water fording and ditch crossing. It offers benefits for the personnel safety of Armed Forces/ Security Forces, in case of handling of any suspicious activity related to chemical, biological, nuclear & radiological agents/ contamination.

### Salient Features:

- On-line detection & Remote monitoring of CBRN contamination
- Day/night video inspection
- Digital Marking of contaminated zones
- CBRN recce in confined spaces (bunkers, buildings, urban areas)
- Range: 1 km LoS, 500 m Near LoS.
- Handheld Operator control Unit



CBRN Mini UGV



Operator Control Unit

### Production Agency:

- M/s Hi-Tech Robotics Pvt Ltd.  
Plot No. 136, Pace City -1, Sec-37,  
Near Hero Honda Chowk,  
Gurgaon - 122001.  
Tel:- +91(124)4715300; Fax:- +91(124)4715398  
Email:- marketing@hitechroboticsystemz.com



8.14

## NBC Reconnaissance Vehicle (NBC RV)

NBC Recce Vehicle on a tracked vehicle is a NBC protected mobile platform for diagnosing the existence of nuclear, biological and chemical agent in the atmosphere during the NBC warfare in order to cordon the contaminated areas and protect the living beings. It carries out survey, detection, identification, monitoring and marking of the radiological and chemically contaminated areas. It is also equipped with sample collection device, which can collect the contaminated soil and liquid samples. It can also transmit data to command centre.

### Salient Features:

- Communication facility for data transmission to command centre
- Navigation facility to identify the location of contaminated zones in the map
- Portable Dose meter and Dose Rate meter for measurement of Dose received by crew
- 30 mm gun on the turret
- Software for predicting the Hazardous areas
- Data integration facility on Control Console
- On line transfer of recce data through telemetry



NBC Reconnaissance Vehicle

### Production Agency:

- Ordnance Factory Board,  
10-A, SK Bose Road, Kolkata - 700 001, West Bengal.  
Ph: +91-33-22430472; Fax: +91-33-22482927; Email: sec.ofb@nic.in
- M/s Bharat Electronics Ltd,  
Outer Ring Road, Nagavara, Bangalore – 560045.  
Ph: +91- 80-25039300; Fax: +91-80-25039211; Email: cmd@bel.co.in

8.15

## Mobile CBRN Detection & Communication (MDC) Vehicle

Mobile CBRN Detection & Communication (MDC) Vehicle consists of sensors required for detection of CBRN warfare agents and for planning of further action. The NBC Filtration System in the vehicle supply NBC filtered air to occupants inside the communication compartment and also to the drivers in driver's cabin through face mask. The Multipurpose Decontamination System in the vehicle is used for decontamination of MDC vehicle, UGV, Personnel & other equipments.

### Salient Features:

- Unmanned Ground Vehicle (UGV) for detection of N&C contamination, sample collection and digital marking of contaminated zones without risk of exposing the personnel
- 10 KVA single phase Genset for providing power supply to all equipments
- 5 KVA UPS to supply uninterrupted power to sensors & other equipments



Mobile CBRN Detection & Communication Vehicle

### Production Agency:

- M/s Dass Hitachi Ltd,  
Dass Hitachi Ltd, 8/9, Milestone, GT Road Sahibabad, PO Mohan Nagar, Ghaziabad – 201 007.  
Ph: +91-120-4755300; Fax: +91-120 4132435; Email: corporate@dhlimited.com
- M/s Enertech Engineering Pvt. Ltd,  
Plot 194/8, Phase-II, Sector-III, Ida Cherlapally City, Hyderabad – 500 051.  
Ph: +91 40 27268002; Fax: +91 40 27268004; Email: bvnrao2k5@gmail.com

8.16

# NBC Protective Equipment

It is a protective equipment to combat the hazardous nature of the chemical and biological agents vis a vis the nuclear agents coupled with their ease of accessibility and ease of preparation. The devices include Respirator Masks, Resuscitator- Manual and Auto, Integrated Hood Mask, Leak Tester and Fitment Tester.

## Salient Features:

- Respirator Masks, Resuscitator have been made out of bromo-butyl rubber
- High Performance and multi-functional fabrics developed for IHM and NBC Suit Mk V
- Developed materials have very high Break Through Time against Real agents
- User friendly Leak and Fitment tester to assess the integrity of the masks before issue



Respiratory Mask



Integrated Hood Mask



Resuscitator (Manual)



Leak Tester

## Production Agency:

### Integrated Hood Mask

- M/s Vijay Sabre Safety Pvt. Ltd, Plot No 35, Chandivali Village, Off Saki Vihar Road, Sakinaka, Sangharsh Nagar, Andheri (E), Mumbai - 400 072.  
Ph-022-28478203, Fax-022-28470021, Email-vijaysabre@vsnl.net; Website:www.vijaysabresafety.com
- M/s Joseph Lesile Dynamiks Mfg. Pvt. Ltd,  
Leslico House, Prof vs Agashe Road, Dadar(West), Mumbai - 400 0028.

### Manual Resuscitator

- M/s Bharart Rubber Industries,  
No B-17, BEL industrial Estate, Jalahalli, Bangalore - 560 013.  
Ph: 080 - 23452786, Fax : 080 - 23450380, Email - bri@bri.net.in, Website: www.bri.net.in



# Chapter - 9



## Materials



9.1

# High Nitrogen Steel (HNS)

HNS is nickel free steel for potential ballistic applications. It has improved ballistic performance compared to Rolled Homogeneous Armour (RHA). It has high strength, ductility, impact toughness and good corrosion resistance.

## Salient Features:

- Tensile strength (Mpa): 850 – 1100 (with varying thickness)
- Hardness (HV): 275 – 370 (with varying thickness)
- Austenitic stainless steel, non-magnetic
- Performance improvement: 30% to 35% compared to RHA steel against soft projectiles
- Performance improvement: 5% to 15% compared to RHA steel against armour piercing (AP) projectiles
- Equivalent performance in comparison to RHA steel against long rod anti-tank projectiles



High Nitrogen Steel (HNS)

## Production Agency:

- Jindal Stainless (Hisar) Ltd,  
Jindal Centre, 12 Bhikaji Cama Place, New Delhi - 110066, INDIA.
- Mishra Dhatu Nigam Ltd,  
PO : Kanchanbagh, Hyderabad - 500 058.  
Ph: +91 40 24340201, Fax: +91 40 24340214, Email: cmd.midhani@ap.nic.in

9.2

# Solvent-Free Anticorrosive Paint

Solvent-free anticorrosive paint is used for corrosion protection of interior compartments of naval ships/submarines. There are two grades of paints, EP-1 for general interior compartments and EP-2 for areas susceptible to damage by chemical spillage (acid). These paints consist of epoxy resin and cured with polyamide (two pack system). These paints are pigmented with suitable pigments and has extenders.

## Salient Features:

- Application : Brush
- Dry film thickness :  $250 \pm 25$  microns/coat
- Pot life : 2 hrs. (min.)
- Interior compartments of ships, Storage tanks for petroleum products, Areas prone to spillage of acids



Solvent-Free Anticorrosive Paint for Battery Pits

## Production Agency:

- M/s Morsun Coating System,  
322, TV Industrial Estate, S.K. Ahire Marg Worli, Mumbai- 400 030.  
Phone: 022 2493 4855/78, Fax: 022 6660 2846, Email: info@morsun.net
- M/s Goa Paints & Allied Products Pvt. Ltd,  
2nd Floor, Cample, Dempo House, Panaji Goa-403 001.  
Phone: 0832 243 7812/13, Fax: 0832 243 7814, Email : goapaints@eth.net
- M/s U K Paints (India) Pvt Ltd,  
19, DDA Commercial Complex Kailash Colony Extn., New Delhi- 110 048.  
Ph: +91-11-29240394, Fax: +91-11-29247864, Email: renuka@britishpaints.in
- M/s Alphagam Coating solution Pvt Ltd,  
GF-7, Business Point, 137 Brigade Road, Bangalore-560025.

9.3

## Heavy Duty Non-Skid Paint

It is used to prevent skidding of personnel and aircrafts on flight, helo and weather decks of naval ships. It also possesses resistance to thermal stresses due to intermittent heating upto 250°C. It consists of epoxy resin cured with polyamide (two pack system). It is pigmented with suitable pigments (titanium dioxide) and has extenders.

### Salient Features:

- Application : Brush
- Dry film thickness : 250±25 microns/coat
- Pot life : 4 hrs. (min.)
- Used on Deck surface, Engine room floors and Surface requiring anti-slip properties



Heavy Duty Non-Skid Paint for Flight Decks

### Production Agency:

- M/s Morsun Coating System, 322, TV Industrial Estate, S.K. Ahire Marg Worli, Mumbai- 400 030. Phone: 022 2493 4855/78, Fax: 022 6660 2846, Email: info@morsun.net, Website: www.morsun.net
- M/s Goa Paints & Allied Products Pvt. Ltd, 2nd Floor, Cample, Dempo House, Panaji Goa-403 001. Phone: 0832 243 7812/13, Fax: 0832 243 7814, Email : goapaints@eth.net
- M/s U K Paints (India) Pvt Ltd., 19, DDA Commercial Complex Kailash Colony Extn., New Delhi- 110 048. Ph: +91-11-29240394, Fax: +91-11-29247864, Email: renuka@britishpaints.in
- M/s Alphagam Coating solution Pvt Ltd, GF-7, Business Point, 137 Brigade Road, Bangalore-560025.
- M/s Anupam Enterprises Poddar Point, 113, Park Street, Block B, 5th Floor, Kolkata-700016
- M/s Akzonobel India Ltd, Plot No 62, P62A, 62B, 43E, Hoskote Industrial Area, Bangalore-562114.
- M/s Shalimar Paints Ltd, Goaberia, P.O. Danesh Shaik Lane, Howrah-711109. Phone: 022-6129-8900, Fax: (022) 6129-8910, Email: info@shalimarpaints.com
- M/s Advance Paints Pvt Ltd., 2nd Fosbery Road, Sewri (East), Mumbai-400 015. Ph: +91-22 2859 0162, Fax: +91-22 2852 8826, Email: info@advancepaints.com
- M/s Excel India Protective Paints Pvt Ltd, Maharashtra Industrial Development Corporation, Badlapur, Mumbai 421503.

9.4

# High Performance Exterior Paint

A high performance exterior paint having prolonged durability for application on superstructure of ship and excellent resistance to marine environmental conditions has been developed. It consists of silicone modified soya alkyd and it is one pack system. It is pigmented with rutile titanium dioxide.

## Salient Features:

- Application : Brush/spray
- Drying time : 3 hrs.
- Dry film thickness :  $40 \pm 5$  microns/coat
- Gloss retention : Excellent
- Chalking resistance : Excellent
- Used in exposed bulkhead and superstructure of ships and structures in marine environment



High Performance Exterior Paint for Ships

## Production Agency:

- M/s Anupam Enterprises, Poddar Point, 113, Park Street, Block B, 5th Floor, Kolkata-700016.
- M/s Akzonobel India Ltd, Plot No 62, P62A, 62B, 43E, Hoskote Industrial Area, Bangalore-562114.
- M/s Morsun Coating System, 322, TV Industrial Estate, S.K.Ahira Marg Worli, Mumbai- 400 030.  
Phone: 022 2493 4855/78, Fax: 022 6660 2846, Email: info@morsun.net
- M/s Goa Paints & Allied Products Pvt. Ltd, 2nd Floor, Cample, Dempo House, Panaji Goa-403 001.  
Phone: 0832 243 7812/13, Fax: 0832 243 7814, Email : goapaints@eth.net
- M/s Shalimar Paints Ltd, Goaberia, P.O.Danesh Shaik Lane, Howrah-711109.  
Phone: 022-6129-8900, Fax: (022) 6129-8910, Email: info@shalimarpaints.com
- M/s Advance Paints Pvt Ltd, 2nd Fosbery Road, Sewri (East), Mumbai-400 015.  
Ph: +91-22 2859 0162, Fax: +91-22 2852 8826, Email: info@advancepaints.com

9.5

## Camouflage and Infrared Reflective (CAM-IRR) Paint

CAM-IRR coatings are superior to traditional paints in that they provide camouflage in addition to providing surface protection and durability. The CAM-IRR coatings, comprising Primer + Topcoat, have specially tailored reflectance values over the Vis-NIR part of the spectrum to match the terrain elements.

CAM-IRR coatings are specially designed for low gloss, and colour matching with the natural surroundings such as sand and vegetation. This makes them blend better with the background, when seen through optical and night-vision devices.

### Salient Features:

- Easy to apply (with hand brush or paint spray gun)
- Single pack system
- Fast drying in normal ambient conditions.
- Good scratch resistance and bending strength
- Shelf Life of 1 year
- Available in different shades



CAM-IRR Paint on MBT Arjun

### Production Agency:

- M/s Advance Paints Pvt Ltd,  
2nd Fosbery Road, Near Hindustan Lever Ltd. Sewri (East), Mumbai-400 015.  
Ph: +91-22 2859 0162, Fax: +91-22 2852 8826, Email: info@advancepaints.com
- M/s Marudhar Paints & Polymers,  
G-800-801, Industrial Area, Phase IV, Boranada, Jodhpur, Rajasthan.  
Ph: +91 02931 281114, Fax: +91 02931 281114, Email: info@marudharpolymers.co.in
- M/s Prolite Paints & Chemicals,  
Plot A/2, Behala Industrial Estate (Behala Chowrasta), 620, Diamond Harbour Road, Kolkata-700034.



9.6

# Polyurea Coatings

In order to reduce the extent of damage during any attack, particularly for blast mitigation and ballistic protection, polyurea coatings are utilised to enhance the strength of existing structures. It is two component system. It can be applied by spray gun.

## Salient Features:

- 100% solid after cure
- 1:1 mix ratio by volume
- Odorless, rapid curable, nearly zero shrinkage, excellent adhesion with substrate (steel and primed concrete) with tunable properties
- Service temperature: (-30 to 250 °C)
- Tensile strength of  $\sim 15.6 \pm 0.5$  MPa and elongation of  $265 \pm 9\%$ .



**Spray Coating Machine**



**Spray Gun**



**Spraying**



**Polyurea coated concrete Slab**

## Production Agency:

- M/s Corrocare Industries,  
Plot No 4718, Phase IV, GIDC, Vatva,  
Ahmedabad, Gujarat – 382445.  
Ph: +91 79 25841705; Fax: +91 79 40083047; Email: vijay@corrocare.com

9.7

## Stratified Coating

It is a high performance exterior paint having prolonged durability for application on superstructure of ship and has excellent resistance to marine environmental conditions. It provides excellent protection and durability. It is spray painted and thus saves times for application.

### Salient Features:

- Separation in two desired coating layers
- No intercoat adhesion failure
- Excellent protective /aesthetic properties
- Time saving during application
- Reduced pollution
- Applied on structures in marine environment

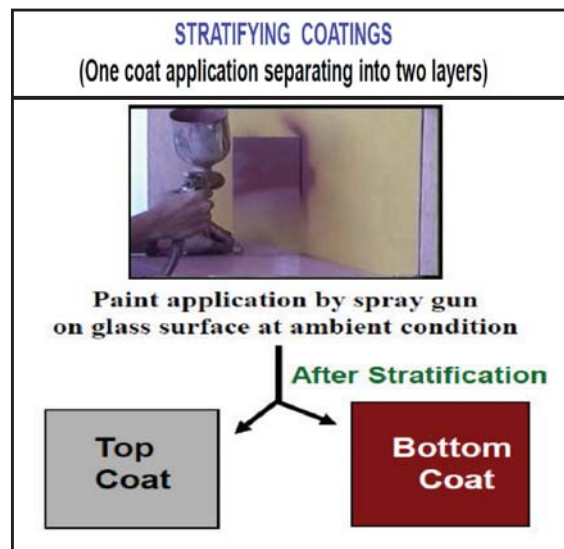

Stratified Coating

### Production Agency:

- M/s Advance Paints Pvt Ltd,  
2nd Fosbery Road, Sewri (East), Mumbai-400 015.  
Ph: +91-22 2859 0162, Fax: +91-22 2852 8826, Email: info@advancepaints.com





Director,  
**Directorate of Industry Interface & Technology Management (DIITM)**  
Room No 447, DRDO HQrs, DRDO Bhawan, Rajaji Marg,  
New Delhi – 110011, INDIA.  
011-23016216, 23007446, 011-23793008 (Fax)  
[diitm@hqr.drdo.in](mailto:diitm@hqr.drdo.in)

*Compiled by DIITM and  
Designed & Printed by DESIDOC*